



# Web Guide

WV-U15501-V3L/WV-U15301-V3L

---

---

# Contents

<b>1.</b>	<b>Set up</b> .....	<b>1</b>
<hr/>		
1.1	Recommended Procedures for Installing this product .....	1
<b>2.</b>	<b>Connect to the camera</b> .....	<b>2</b>
<hr/>		
2.1	i-PRO Configuration Tool (iCT) .....	2
2.2	IP Setting Software .....	2
2.3	Access the camera .....	2
2.4	About Live image pages .....	4
<b>3.</b>	<b>Set the camera</b> .....	<b>6</b>
<hr/>		
3.1	Adjust the image quality .....	6
3.1.1	Set the light intensity control mode depending on the installation location and installation area. ....	6
3.1.2	Set white balance depending on the lighting environment you install. ....	6
3.1.3	Sets night time black-and-white switching mode .....	7
3.2	Recording setting (SD Memory Card) .....	8
3.2.1	Install the SD Memory Card .....	8
3.2.2	Record using SD Memory Card .....	8
3.2.3	Play back images stored on the SD Memory Card .....	9
3.3	Adjust the zoom/focus .....	9
3.4	Hide some of the images .....	10
3.5	Set up events .....	10
3.5.1	Detect object movements .....	10
3.6	Enhance communication security .....	11
3.7	Detect data falsification .....	12
3.8	Set the Image capture size and frame rates .....	12
3.9	Set the overlay image function .....	12
3.10	Set the image stream .....	13
3.10.1	About Stream Settings .....	13
3.10.2	About delivery volume control (bit rate) .....	13

---

3.10.3	Reducing Data Capacity with Smart Coding .....	14
3.11	Set the i-VMD .....	14
3.11.1	Manage the i-VMD .....	14
3.11.2	Scheduling a i-VMD .....	15
<b>4.</b>	<b>Clean up .....</b>	<b>16</b>
4.1	Cleaning of lenses .....	16
<b>5.</b>	<b>Specifications .....</b>	<b>17</b>
5.1	PC environment required .....	17
5.2	About Image capture mode and Image capture size .....	17
5.2.1	Image capture size .....	18
5.2.2	Restrictions .....	20
5.3	DORI .....	20
5.4	Streaming performance .....	21
5.5	Extension software .....	21
5.6	Lamp .....	22
5.6.1	Lighting the Lamp .....	23
5.7	Button .....	24
5.8	Cable .....	25
<b>6.</b>	<b>Other .....</b>	<b>26</b>
6.1	Initialize .....	26
6.2	Check the software version .....	26
6.3	Upgrade software .....	27
6.4	Order of setting when adjusting image quality .....	27
6.5	Adjusting object brightness (bright scenes) .....	28
6.5.1	Adjusting brightness .....	28
6.6	Adjusting object brightness (dark scenes) .....	28
6.6.1	Adjust the maximum gain .....	28
6.6.2	Adjust the maximum shutter .....	29
6.7	Reducing white flickering and blacking on the screen .....	29
6.7.1	Set Super Dynamic .....	29
6.7.2	Set the backlight compensation .....	30
6.7.3	Set the high light compensation .....	31

---

6.7.4	Adjust the adaptive black stretch .....	31
6.7.5	Adjust the [Pedestal level] .....	32
6.8	Adjust the object contrast .....	32
6.8.1	Adjust the contrast .....	32
6.9	Reduce flicker .....	33
6.10	Reducing the blur of object (bright scenes) .....	33
6.10.1	Set intelligent auto .....	33
6.10.2	Adjust the maximum shutter .....	34
6.11	Reducing object blur (dark scenes) .....	35
6.11.1	Adjust digital noise reduction .....	35
6.12	Sharpen the outline of the subject .....	35
6.12.1	Adjust the sharpness level .....	35
6.13	Adjust the color .....	36
6.13.1	Adjust color density .....	36
6.13.2	Adjust the white balance .....	36
6.14	Reducing object noise (bright scenes) .....	37
6.14.1	Adjust the sharpness level .....	37
6.15	Reducing object noise (dark scenes) .....	37
6.15.1	Adjust digital noise reduction .....	37
6.16	Set focus when switching between black and white. ....	38
6.16.1	Focus adjustment method for switching between black and white .....	38
6.17	Troubleshooting .....	39
6.18	Precautions pertaining to usage .....	40
6.19	Disclaimer .....	42
6.20	For trademarks and registered trademarks .....	43
6.21	NETWORK RELATIONSHIP .....	43

1. Set up
  - 1.1 Recommended Procedures for Installing this product
- 

# 1. Set up



For detailed installation instructions, refer to the following:  
[Installation section](#)

## 1.1 Recommended Procedures for Installing this product

The URL of the movie is as follows.

<https://www.youtube.com/playlist?list=PLTQfvT0fJHvBPqSZ58IFN-hyJ92hU2kwz>

- 2. Connect to the camera
  - 2.3 Access the camera
- 

## 2. Connect to the camera

### 2.1 i-PRO Configuration Tool (iCT)

This is a tool for managing the image monitoring system at a glance.



For more information about i-PRO Configuration Tool (iCT), see the Technical Information website at <Control No.: C0133>.

→[Click here for more information about i-PRO Configuration Tool](#)

### 2.2 IP Setting Software

Cameras or recorders on the same network can be automatically detected and set up in the network.



For more information on the IP Setting Software, see the Technical Information website at <Control No.: C0123>.

→[Click here for more information on the IP Setting Software](#)

### 2.3 Access the camera

1. Launch a IP Setting Software
  - The model number and MAC address of the detected camera are displayed.
  - The default for [Network Settings] is [DHCP].



•If you cannot obtain an IP address from the DHCP server, set the IP address to 192.168.0.10.

2. Connect to the camera
  - 2.3 Access the camera
- 

2. Double-click on the camera's IP address
  - The browser starts and the administrator registration screen is displayed.
  - You need to register as an administrator.

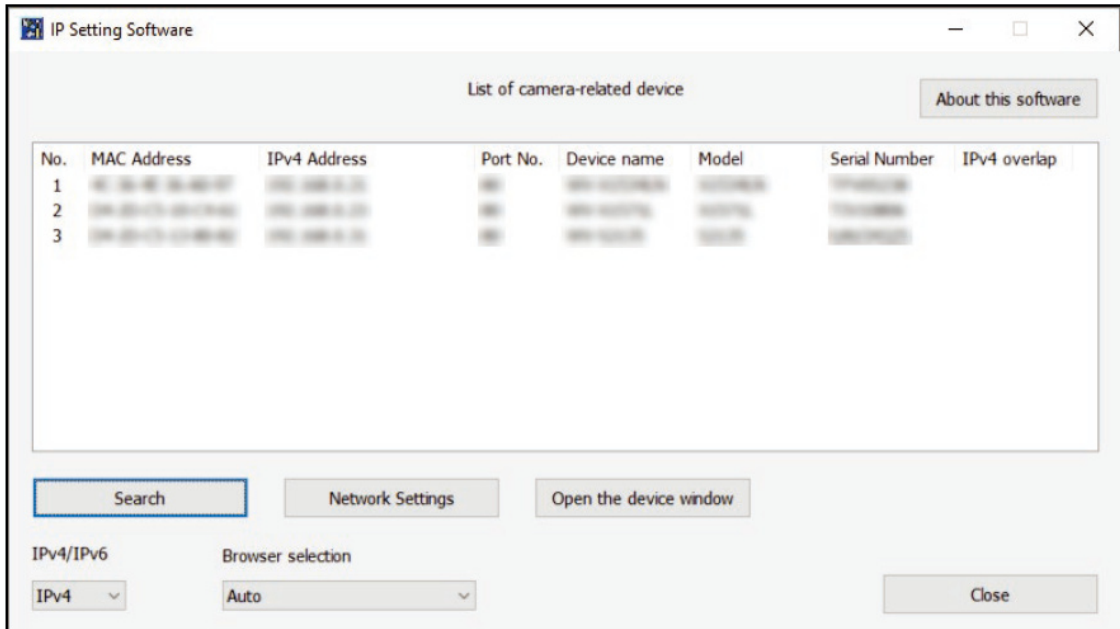

3. Enter administrator username and password
  - The screen for setting the language and date and time is displayed.
4. Set the language, date and time, and screen
  - You can set the language and date and time and change the background color of the screen and the layout of the operation panel.
5. Press [Set]
  - Live image pages is displayed.

- 2. Connect to the camera
- 2.4 About Live image pages

## 2.4 About Live image pages

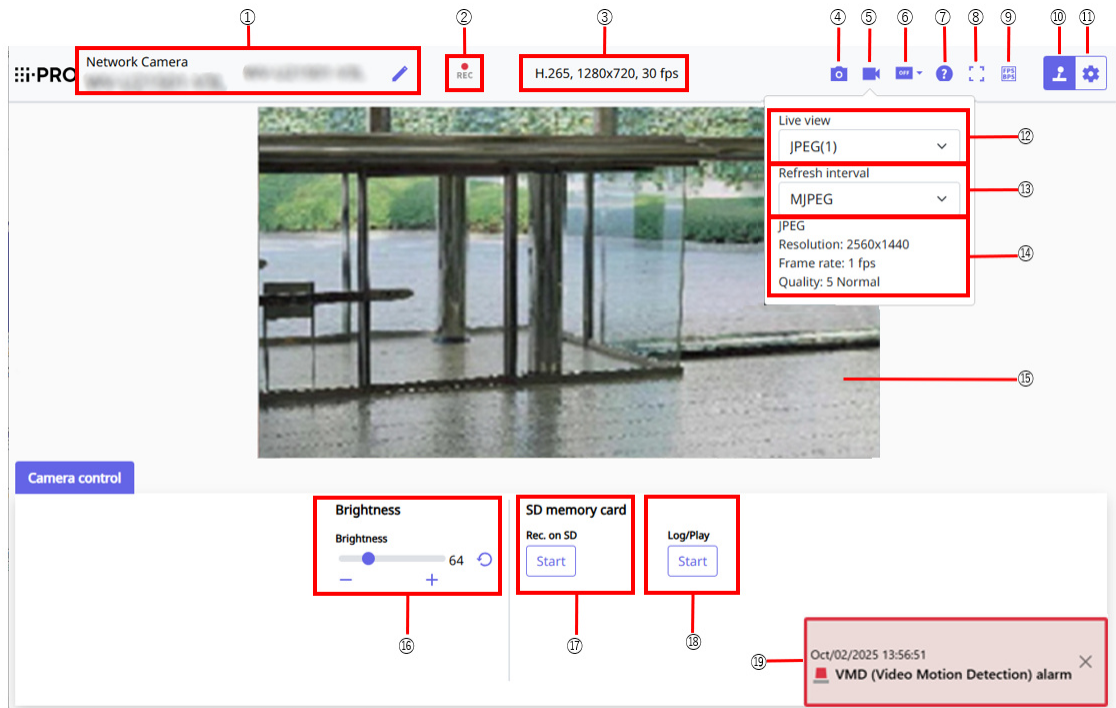

- ① Camera title
- ② SD storage status display
- ③ Stream information display
- ④ Snapshot button
- ⑤ Stream selection display button
- ⑥ Before/after image comparison switching button
- ⑦ Support button
- ⑧ Full Screen View button
- ⑨ Frame rate/bit rate display button
- ⑩ Camera control panel display button
- ⑪ [Setup] buttons (Settings panel display button)
- ⑫ Select Streams-[Live only] pull-down menu
- ⑬ Select Streams-[Refresh Rate] pull-down menu
- ⑭ Select Streams-Display Stream Information
- ⑮ Main area
- ⑯ Camera Control Panel-[Brightness]
- ⑰ Camera Control Panel-SD Memory Card-[Rec. on SD] button
- ⑱ Camera Control Panel-SD Memory Card-[Log/Play] button

- 2. Connect to the camera
  - 2.4 About Live image pages
- 

⑩ Alarm notification

## 3. Set the camera

### 3.1 Adjust the image quality

This section explains how to adjust the image quality when installing the camera.

#### 3.1.1 Set the light intensity control mode depending on the installation location and installation area.

Use [Light control mode] to set the light intensity appropriate for the installation location and area.

➤ Live image pages configuration panels>Clicking the [Image quality] tabs enables you to set the image quality.

1. Select [Light control mode]

- To install outdoors: Set [Outdoor scene].
- For indoor installation: Set [Indoor scene(50Hz)] or [Indoor scene(60Hz)].  
50 Hz/60 Hz can be used differently depending on the region.



- Basically, [Fix shutter] is not used.
- For more information about the light control mode, refer to the User Manual.

#### 3.1.2 Set white balance depending on the lighting environment you install.

Use [White balance] to set the white balances appropriate for the installation location and area.

➤ Live image pages configuration panels>[Detailed setting]>[Camera detailed setting]>[Image] or [Image/Audio] of the Advanced menus on the left>[Image adjust] in the [Image quality] tabs>When [Setup] is clicked, the image quality adjustment setting window is displayed.

1. Select [White balance]

- Select from [ATW1], [ATW2], and [AWC].

3. Set the camera  
3.1 Adjust the image quality

---

**[ATW1]**

Set the automatic color temperature tracking mode. The camera continuously checks the color temperature of the light source and automatically adjusts the white balance.

The operating range is about 2700 K to 6000 K.

**[ATW2]**

Set the automatic color temperature tracking mode. The camera automatically adjusts the white balance under a sodium lamp.

The operating range is from about 2000 K to 6000 K.

**[AWC]**

Set the automatic white balance control mode. Since the light source is fixed, it is suitable for shooting in a place where the lighting environment does not change.

The operating range is from approximately 2000 K to 10000 K.



Colors may not be reproducible faithfully if the following conditions are met: In such cases, set it to [AWC].

- Largely dark object
- Clear blue sky or the sun at dusk
- Object with too low illumination

### 3.1.3 Sets night time black-and-white switching mode

You can switch to color or black-and-white images by using [Day & Night(IR)] when shooting at night.

➤ Live image pages configuration panels>Clicking the [Image quality] tabs enables you to set the image quality.

1. Select [Day & Night(IR)]
  - Select [Off], [On(IR Light Off)], [On(IR Light On)], [Auto1(IR Light Off)], [Auto2(IR Light On)], and [Auto3(SCC)].

**[Off]**

This function is used for shooting colored images at night as well.

**[On(IR Light Off)]**

The picture is always taken in black and white.

3. Set the camera  
3.2 Recording setting (SD Memory Card)

---

**[On(IR Light On)]**

The picture is always taken in black and white. This setting is used when near-infrared lighting is used at night.

**[Auto1(IR Light Off)]**

The color image and black-and-white image are automatically switched depending on the brightness (illumination) of the image.

**[Auto2(IR Light On)]**

The color image and black-and-white image are automatically switched depending on the brightness (illumination) of the image. This is set when the near-infrared illumination is used at night.

**[Auto3(SCC)]**

Set this when you want to maintain a color image even when the light source is dark. The Super Chroma Compensation (SCC) function maintains the color image to low illumination.

## 3.2 Recording setting (SD Memory Card)

### 3.2.1 Install the SD Memory Card

1. Insert a microSD memory card into the slot



Use the SD Memory Card formatted on this product.



To remove the SD Memory Card, [Basic] the Advanced menu.>On the [SD memory card] tab, select [SD memory card] as [Not use]. Remove the SD Memory Card from this product.

### 3.2.2 Record using SD Memory Card

This section describes the procedures for turning [Save trigger] to [Manual].

### 3. Set the camera

#### 3.3 Adjust the zoom/focus

---

- Live image pages configuration panels>[Detailed setting]>[Camera detailed setting]> [Basic] of the Advanced menus on the left>When [SD memory card] tab is clicked, the SD Memory Card setup page is displayed.
- (1) Select [Recording format] streams
- (2) Select [Save trigger] and click [Set].
- (3) Click [Live] in the upper left corner and click the camera control panel display button.
  - The camera control panel is displayed.
- (4) Clicking [Start] on [Rec. on SD]
  - Start recording to the SD Memory Card manually.
  - You can stop recording by clicking [Stop]. After stopping, you can resume recording by clicking [Start].

#### 3.2.3 Play back images stored on the SD Memory Card

You can play back images stored on the SD Memory Card.

- Live image pages cameras control panels>Clicking [Log/Play] displays the log list.
- 1. View Live image pages and click the camera control panel display button.
- 2. Press the [Start] on [Log/Play] button
  - The Log List screen is displayed in a separate window.
- 3. Press the shooting date and time displayed below [Time & date]
  - The playback page is displayed and the saved image is played.

### 3.3 Adjust the zoom/focus

You can adjust the zoom and focus of the displayed image manually or automatically.

- Live image pages settings pane>Clicking [Zoom] displays the setting window.
- 1. Adjusting the [Zoom ratio designation], [Zoom], [Focus], and [Auto focus]



•For more information about zooming and focus, see the User Manual.

## 3.4 Hide some of the images

If you set the area to be hidden, you can move the camera's field angle while holding the area to be hidden.

- Live image pages configuration panels>[Detailed setting]>[Camera detailed setting]>[Image/Audio] of the Advanced menus on the left>[Privacy zone] in the [Image quality] tabs>When [Setup] is clicked, the Privacy Zone setting window is displayed.

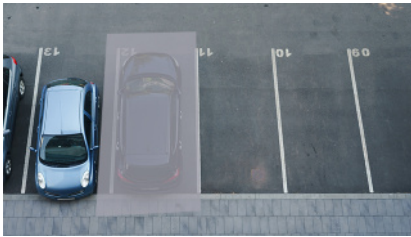

1. Specify four vertices on the image and press [Set] button.
  - Privacy zones are set in order from Area 1.
2. Select [Status] to view privacy zones
  - Set up the privacy zone in [On]/[Off].

## 3.5 Set up events

You can set the alarm to detect the operation of an area or interference to the camera, or the operation when the alarm is detected.

- Live image pages configuration panels>[Detailed setting]>[Camera detailed setting]>[Easy Setup] of the Advanced menus on the left>Clicking on the [Event action] tabs displays the configuration pages.



- Refer to the User Manual for instructions on configuring events.
- Refer to the User Manual for instructions on how to configure Internet disclosure.

### 3.5.1 Detect object movements

When an alarm is activated, the camera operates as set. There are patterns for the alarms when the specified area moves and when the camera is blocked.

3. Set the camera  
3.6 Enhance communication security

---

- Live image pages configuration panels>[Detailed setting]>[Camera detailed setting]>[Alarm] of the Advanced menus on the left>Clicking on the [VMD area] tabs displays the configuration pages.



Refer to the user manual for details of all alarms.

### 3.5.1.1 Set the area for detecting the movement of an object

Set the area for detecting the movement of an object using the motion detection function using video images.



1. Drag through the image to set the area.
  - You can set the areas in order.
2. Adjust the [Detection area] and [Detection sensitivity] using the slider bar and then press [Set].

## 3.6 Enhance communication security

Setting up HTTPS encrypts camera access and enhances communication security.

- Refer to the following support videos for the HTTPS setting method (pre-installation).  
→[Support video](#)
- For information about how to configure HTTPS (CA certificate), refer to the following supported videos.  
→[Support video](#)

- 3. Set the camera
  - 3.9 Set the overlay image function
- 

## 3.7 Detect data falsification

If you set Falsification Detection, you can detect the falsified data on the SD Memory Card using the dedicated software.

Refer to the following support videos for how to set up tampering detection.

→[Support video](#)

## 3.8 Set the Image capture size and frame rates

➤ Live image pages configuration panels>[Stream] tabs>Set in [Image capture mode] of [Common].



•For details on the settings and frame rates, refer to the user manual.

•For details on the resolution, see the following:

→[About Image capture mode and Image capture size](#)

## 3.9 Set the overlay image function

You can specify the position to overlay the uploaded image or specify the color to be transmitted. In the model where the SD Memory Card can be recorded, the overlay displayed images are recorded during recording.

Refer to the User Manual for details on how to configure the settings.

- Live image pages configuration panels>[Detail setting]>[Camera detailed setting]>[Basic] of the Advanced menus on the left>Configure in the [Overlay image] tabs.
  1. Select an image with [Overlay] set to [On].
  2. Set [Position], [Permeation], and [Selection of color to be penetrated]
  3. Press [Set]

## 3.10 Set the image stream

### 3.10.1 About Stream Settings

Specify whether to distribute streams, whether to use H.265 or H.264 as the compression method, the resolution, image quality, and how to distribute the data.

- Live image pages settings pane>This is done in the [Stream] tab.. H.265 images and H.264 images are streamed in the [Stream] section of the [Stream].
- For information on image compression methods, see the following:
  - [Reducing Data Capacity with Smart Coding](#)
- For information on how to deliver, see the following:
  - [About delivery volume control \(bit rate\)](#)
- For details on each setting method, refer to the user manual.

### 3.10.2 About delivery volume control (bit rate)

There are the following types of delivery modes for stream delivery volume control (bit rate), and they are set according to the case. You can also use smart coding, such as [Auto VIQS], to reduce the volume. For information about controlling the delivery of streams, see the following: For details, refer to the user manual.

→[Reducing Data Capacity with Smart Coding](#)

- **Constant Bit Rate :**
  - Delivers H.265 (or H.264) images at the bitrate set in [Max bit rate (per client) \*].
- **Variable bit rate :**
  - Delivers H.265 (or H.264) images at the frame rate set in [Frame rate\*] while maintaining the image quality level set in [Image quality]. At this time, the bit rate is distributed with a variable value within the maximum bit rate set in [Max bit rate (per client) \*]. The recording capacity varies depending on the [Image quality] setting and the object status.
- **Frame rate specification:**
  - Delivers H.265 (or H.264) images at the frame rate set in [Frame rate\*].
- **Best effort delivery:**
  - Depending on the bandwidth of your network, you can distribute H.265 (or H.264) images at varying bit rates, up to the maximum bit rate set in [Max bit rate (per client) \*].

### 3.10.3 Reducing Data Capacity with Smart Coding

Smart coding is a data-compression technique that reduces the amount of compression to sharpen human faces, increases the amount of compression in the background, or optimizes the amount of compression by object.

- Live image pages settings pane>[Detail setting]>[Camera detailed setting]>[Image], or [Image/Audio] in the Advanced menu on the left>Clicking [Image] brings up the Smart Coding Settings window.

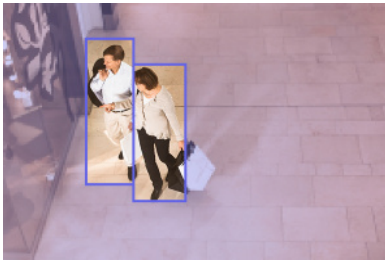

This image is an image. It differs from how the screen is actually viewed.

#### [Auto VIQS]

Keeps the image quality of moving parts high. The image quality in the area where there is no movement will be the image quality where the amount of data decreases, and then the image will be distributed.

#### [GOP control]

You can reduce the amount of data.

## 3.11 Set the i-VMD

The i-VMD page allows you to manage and schedule i-VMD.

- Live image pages settings pane>[Detail setting]>[Camera detailed setting]>Clicking [i-VMD] in the Advanced menu on the left displays a tabbed page of functions.

### 3.11.1 Manage the i-VMD

The i-VMD will be updated. You can also view the [i-VMD setup menu] and configure the [i-VMD] settings by clicking [Setup >>] in the [Setup menu].

### 3. Set the camera

#### 3.11 Set the i-VMD

---

- Live image pages settings pane>[Detail setting]>[Camera detailed setting]>[i-VMD] in the Advanced menu on the left>Clicking the [i-VMD Manager] tab. The setting page is displayed.
- (1) Downloading the most recent i-VMD to the PC
- (2) Specify the downloaded [i-VMD] by clicking [Select a file].
- (3) Make sure that [Upgrade i-VMD] is selected and then press [Execute].
  - The [i-VMD] is upgraded.
- (4) By clicking [Setup >>] in the [Setup menu]
  - Displays the [i-VMD setup menu] and allows you to configure the [i-VMD] settings.



- Please use the most recent version of i-VMD.
- When using i-VMD, free RAM space must be at least 50MB.
- If there is not enough RAM space available, i-VMD cannot be used. If you want to use the i-VMD, uninstall the Extension software installed on the [Software mng.] tab. Alternatively, set [RAM capacity expansion mode] to [On].
- If i-PRO Remo. Service is enabled, the i-VMD may become unavailable.



- For more information about [i-VMD setup menu], see "3.2 Choosing Behavior" and subsequent sections of this section.

→[https://i-pro.com/products\\_and\\_solutions/ja/surveillance/media/documentation\\_file/doc/support\\_and\\_documentation/xae200w-webguide-ja-pdf](https://i-pro.com/products_and_solutions/ja/surveillance/media/documentation_file/doc/support_and_documentation/xae200w-webguide-ja-pdf)

#### 3.11.2 Scheduling a i-VMD

You can set the i-VMD operation by specifying the day of the week and the hour.

- Live image pages settings pane>[Detail setting]>[Camera detailed setting]>[i-VMD] in the Advanced menu on the left>Clicking [Operation schedule] displays the settings page.
- (1) In the [Display], select the days of the week and the timetable for which you want to schedule.
- (2) In the [Time table] [Operation content], specify the timezone to operate.
- (3) Press the [Set] key



- To operate the i-VMD for 24 hours, set [00:00] to [00:00].

## 4. Clean up



- Turn off the power before starting operation. Doing so may result in injury.
- Do not apply or use organic solvents such as benzene and thinner. The case may become discolored. Follow the precautionary statement when using chemical foil.
- Do not loosen or remove the screws not specified in the operation manual.

### 4.1 Cleaning of lenses



- Clean with lens cleaning paper (for cleaning cameras and eyeglasses).
- Alcohols should be used when solvents are used. Do not use glass cleaners or thinners.

## 5. Specifications

### 5.1 PC environment required

CPU:	Intel®Core™Processor families <Use at a resolution up to 1920 x 1080> -Intel®Core™i5-6500 or higher -Intel®Core™i7-6700 or more recommended <Use at resolutions higher than 1920 x 1080> -Intel®Core™i7-11700 or more recommended
Memory:	<Use at a resolution up to 1920 x 1080> 2 4 GB(2 GB, dual-channel or more recommended) <Use at resolutions higher than 1920 x 1080> 2 16 GB(8 GB, dual-channel or more recommended)
Network capability :	10BASE-T, 100BASE-TX or 1000BASE-T 1
Sound function:	Sound card (when using audio function)
Image display function:	Resolution: 1920 x 1080 pixels or higher <3840 x 2160 resolution usage> High resolution monitoring: 3840 x 2160 pixels or higher Color development: True Color 24 or more
Supported OS:	Microsoft Windows 11
Web browser:	Google Chrome™ Firefox Microsoft Edge(Chromium version or later)
Other:	Adobe®Reader®Or Acrobat Reader®(to view PDF files)

### 5.2 About Image capture mode and Image capture size



- The bit rate of streams is restricted to [Bandwidth control(bit rate)] on the [Network] tabs of network pages.
- If the refresh interval is short, the bit rate may be exceeded depending on the object.

5. Specifications

5.2 About Image capture mode and Image capture size

- Depending on the number of concurrent users or the combination of functions used, the bit rate may be lower than the set value. Confirm the image delivered after setting.

5.2.1 Image capture size

The resolution. Initial values are underlined.

WV-U15501-V3L

Image capture mode	Stream (1)	Streams(2)	Streams(3)	Streams(4)	JPEG(1)*1	JPEG(2)
<u>16:9(30fps)</u>	<u>2560x1440</u>				<u>2560x1440</u>	
16:9(25fps)	1920x1080 1280x720	<u>1280x720</u> 640x360 320x180*3	<u>640x360</u> 320x180*3	<u>640x360</u> 320x180*3	1920x1080 1280x720 640x360 320x180*3	<u>640x360</u>
	Max 30(25) fps	Max 30(25) fps	Max 30(25) fps	Max 30(25) fps	Max 5(4.2) fps*4*5	Max 15(12.5) fps*5
4:3(30fps)*2	2592x1944		—	—	2592x1944	
4:3(25fps)*2	2560x1920 1280x960	640x480 320x240			2560x1920 1280x960 640x480 320x240	640x480
	Max 30(25) fps	Max 30(25) fps			Max 5(4.2) fps*4*6	Max 15(12.5) fps
4:3(15fps)*2	2592x1944				2592x1944	
4:3(12.5fps)*2	2560x1920 1280x960	1280x960 800x600 640x480 400x300 320x240	640x480 320x240	640x480 320x240	2560x1920 1280x960 800x600 640x480 400x300 320x240	640x480
	Max 15(12.5) fps	Max 15(12.5) fps	Max 15(12.5) fps	Max 15(12.5) fps	Max 5(4.2) fps*6	Max 15(12.5) fps

\*1You can select the same resolution as that set for stream (1), stream (2), stream (3), stream (4), and JPEG (2).

5. Specifications

5.2 About Image capture mode and Image capture size

\*2When "4:3" is selected in "Imaging Mode", "90° " and "270° " are not available in [Image rotation].

\*3When the picture resolution is "320x180", "90° " and "270° " cannot be set in [Image rotation].

\*4When the image resolution is "2560 x 1440 (2592 x 1944)", the image refresh rate is limited to the largest 2fps(2.1fps).

\*5If [Stream transmission] is set to [Off], the max. frame rate is 30 fps(25 fps).

\*6If [Stream transmission] is set to [Off], the max. frame rate is 15 fps(12.5 fps).

WV-U15301-V3L

Image capture mode	Stream (1)	Streams(2)	Streams(3) *4 *5	Streams(4) *4 *5	JPEG(1)	JPEG(2)
<u>16:9(30fps)</u>	<u>1920x1080</u>	1920x1080			<u>1920x1080</u>	
16:9(25fps)	1280x720	1280x720	1280x720		1280x720	
	640x360	<u>640x360</u>	640x360	640x360	640x360	<u>640x360</u>
	320x180*2	320x180*2	320x180*2	320x180*2	320x180*2	
	Max 30(25)fps	Max 30(25)fps	Max 15(12.5)fps	Max 15(12.5)fps	Max 5(4.2)fps*3	Max 15(12.5)fps*3
4:3(30fps)*1	1280x960	1280x960			1280x960	
4:3(25fps)*1	640x480	640x480	640x480	640x480	640x480	640x480
	320x240	320x240	320x240	320x240	320x240	
	Max 30(25)fps	Max 30(25)fps	Max 30(25)fps	Max 30(25)fps	Max 5(4.2)fps*3	Max 15(12.5)fps*3

\*1When "4:3 (30fps/25fps)" is selected for "Imaging mode", "90° " and "270° " cannot be set for [Image rotation].

\*2When the picture resolution is "320x180", "90° " and "270° " cannot be set in [Image rotation].

\*3If [Stream transmission] is set to [Off], the max. frame rate is 30 fps(25 fps).

\*4The default [Stream transmission] for stream (3) and stream (4) is [Off].

\*5When the [Stream transmission] of the stream (1) is [On] and the resolution of the stream (2) is set to "1920x1080", the [Stream transmission] of the stream (3) and the stream (4) is [Off].

### 5.2.2 Restrictions

	WV-U15501-V3L		WV-U15301-V3L
Function	16:9(30/25fps) 4:3(30/25fps)	4:3(15/12.5fps)	16:9(30/25fps) 4:3(30/25fps)
Extension software	Yes	Yes	Yes
i-VMD	Yes*1	Yes*1	Yes*1
Image rotation	Yes*2	Yes*2	Yes*2
SD recording	Yes	Yes	Yes
Smart coding	Yes	Yes	Yes
Super Dynamic	Yes	Yes	Yes
Privacy zone	Yes	Yes	Yes
Remote Monitoring	Yes*3*4	Yes*3*4	Yes*3*4

\*1When "Remote Monitoring" is set to "Enable", "i-VMD" cannot be used.

\*2When "4:3" is selected for "Image capture mode", the "90 °" or "270 °" cannot be set for "Image rotation".

\*3When "i-VMD" is running, "Remote Monitoring" cannot be used.

\*4When "RAM capacity expansion mode" is set to "On", you cannot use "Remote Monitoring".

## 5.3 DORI

### WV-U15501-V3L

	WIDE	TELE
Detect (25 ppm/8 ppf)	41.5 m {136.0 ft}	205.4 m {673.7 ft}
Observe (62.5 ppm/19 ppf)	16.6 m {54.4 ft}	82.1 m {269.5 ft}
Recognize (125 ppm/38 ppf)	8.3 m {27.2 ft}	41.1 m {134.7 ft}
Identify (250 ppm/76 ppf)	4.1 m {13.6 ft}	20.5 m {67.4 ft}

### WV-U15301-V3L

	WIDE	TELE
Detect (25 ppm/8 ppf)	24.9 m {81.8 ft}	138.5 m {454.3 ft}
Observe (62.5 ppm/19 ppf)	10.0 m {32.7 ft}	55.4 m {181.7 ft}
Recognize (125 ppm/38 ppf)	5.0 m {16.4 ft}	27.7 m {90.9 ft}
Identify (250 ppm/76 ppf)	2.5 m {8.2 ft}	13.8 m {45.4 ft}

## 5.4 Streaming performance

- Up to 14 users are accessible at the same time.
- The maximum bandwidth is 50 Mbps.

## 5.5 Extension software

Information about the number and capacity of Extension software (applications) that can be installed.

### WV-U15501-V3L

Number of applications installed	Application capacity (ROM capacity)	Application capacity (RAM capacity)
1	100 MB	50 MB

### WV-U15301-V3L

Number of applications installed	Application capacity (ROM capacity)	Application capacity (RAM capacity)
1	100 MB	100 MB



For the latest software (AI application) support status and restrictions, please check the technical information <Control No.: C0103> on our website.

→ [Technical information website](#)

Software (AI apps)	Pre-install	Support status
i-VMD	Yes*1	Supported*1

\*1The i-VMD is mounted as the main unit function.

## 5.6 Lamp

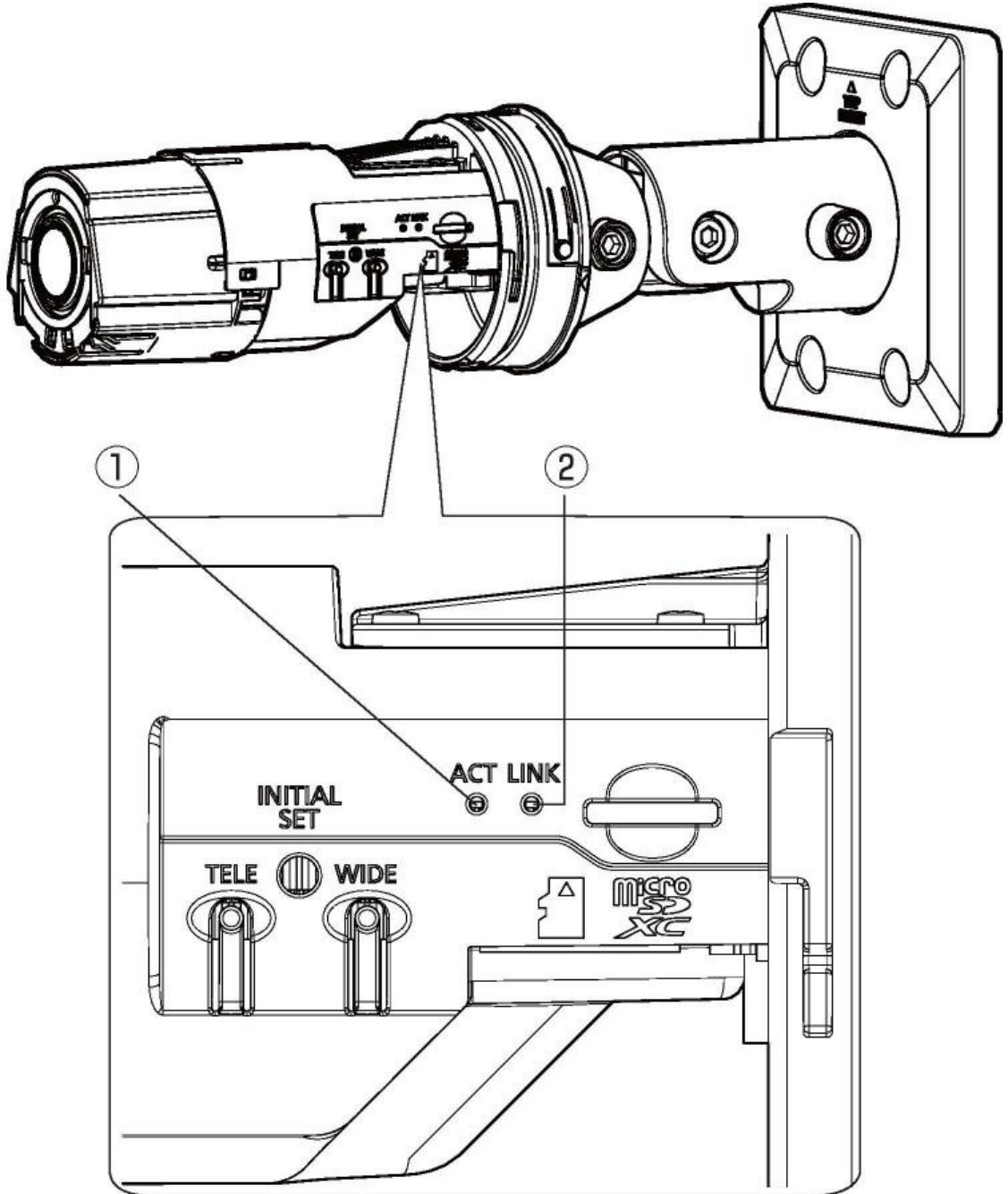

- ① [ACT] Lamp
- ② [LINK] Lamp

### 5.6.1 Lighting the Lamp

#### [ACT] Lamp

When the camera sends or receives data

- Blinking green (accessing)

#### [LINK] Lamp

When communication with connected devices is enabled

- Illuminated in orange

## 5.7 Button

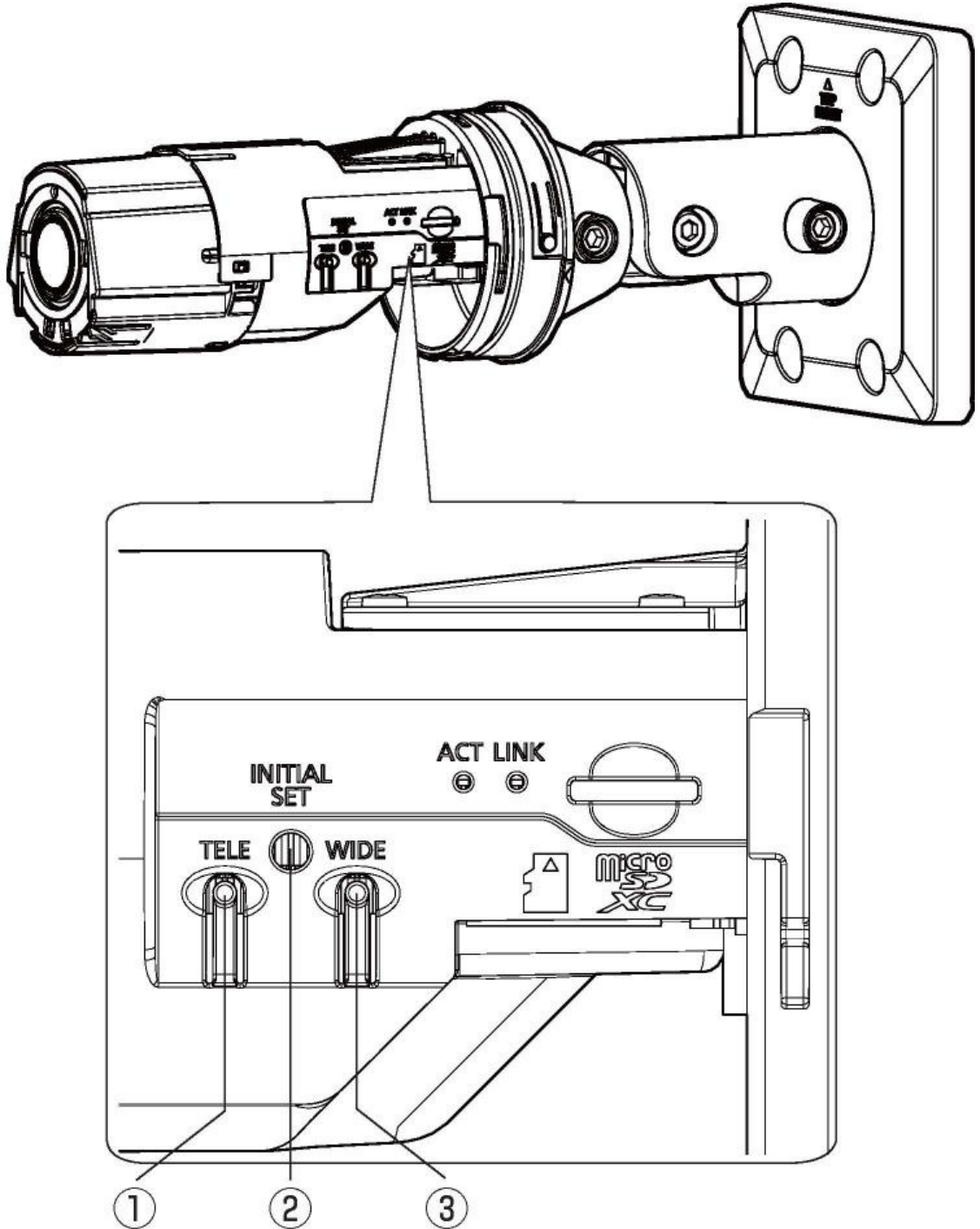

- ① TELE+AF key
- ② INITIAL SET key
- ③ WIDE+AF key

## 5.8 Cable

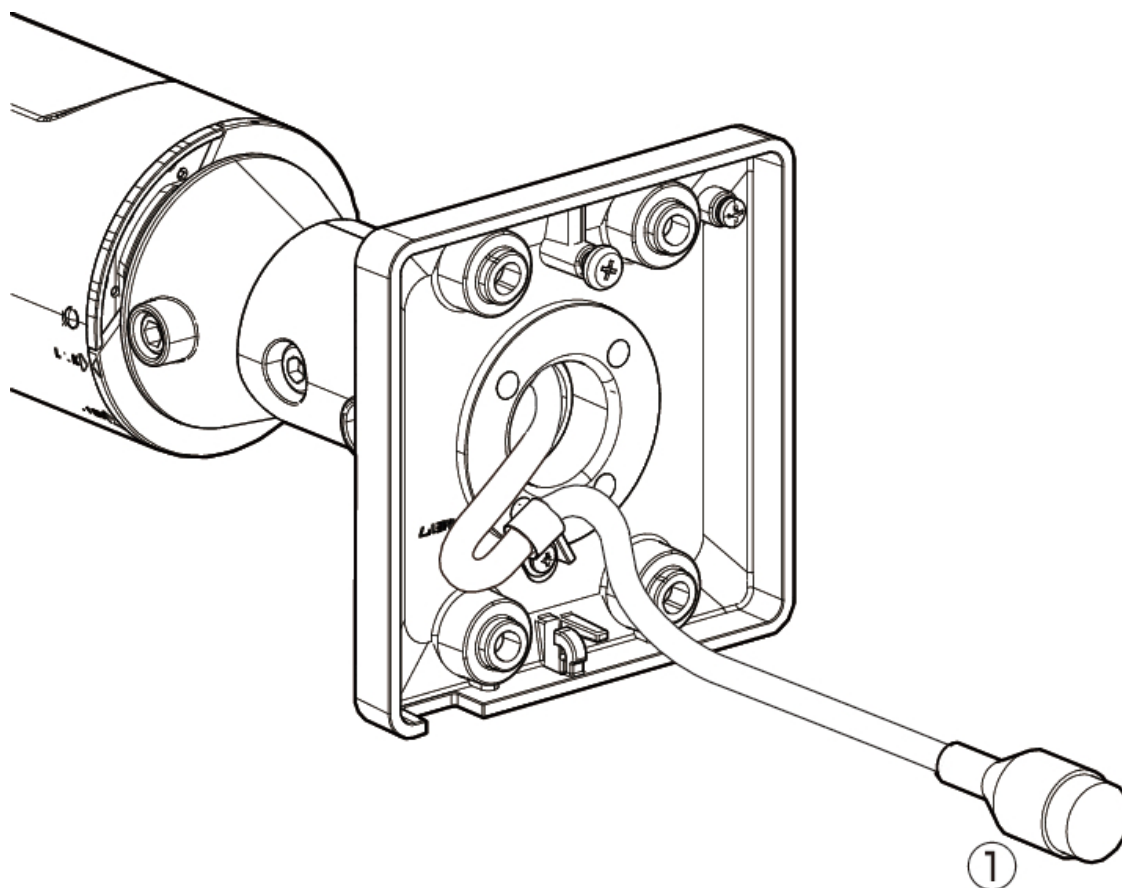

- ① Ethernet cable with RJ45 network cable /RJ45 plug (category 5e or higher, straight, 4 pairs (8 cores), less than 100 m)

## 6. Other

### 6.1 Initialize

INITIAL SET Press the button to initialize the unit. INITIAL SET For the location of the buttons, refer to the following:

→ [Button](#)

1. Turn off the power of this product.
2. Turn on the power of this product while pressing the [INITIAL SET] button.
3. Press the [INITIAL SET] button for 15 seconds or longer after the power is turned on.
4. Release the INITIAL SET button
  - Approximately two minutes later, this product is started and the settings containing the network settings are initialized. If it does not start normally, try again.

### 6.2 Check the software version

The functions of this product are implemented in software. We recommend that you first check the current software version if there is a problem with the operation of this product.

➤ Live image pages configuration panels > [Detailed setting] > [Camera detailed setting] > [Maintenance] of the Advanced menus on the left > Clicking on the [Upgrade] tabs displays the versioning window.

1. Check software versions with [Firmware version]
  - The current software version can be checked.



Up-to-date versions of software may contain modifications to specific problems.

## 6.3 Upgrade software

➤ Live image pages configuration panels>[Detailed setting]>[Camera detailed setting]>[Maintenance] of the Advanced menus on the left>When the [Upgrade] tabs are clicked, the software-upgradeable window is displayed.

1. Download the latest software to the PC
2. Click Select Files to specify the software you downloaded, and then click [Execute].



- Use a PC on the same subnet as this product to upgrade the version.
- Do not turn off the power of this product during version upgrading. Do not perform any operation until the version upgrade is completed.
- Be sure to check the version after upgrading. Also, delete the temporary Internet file.

## 6.4 Order of setting when adjusting image quality

It is recommended to set the settings for image quality in the following order: Adjustment of visibility → Adjustment of color → Removal of noise.

1. Adjust the visibility
  - [Light control mode], [Intelligent auto], [Super Dynamic], [Contrast level], [High light compensation(HLC)], [Adaptive black stretch], [Adaptive highlight stretch], [Maximum gain], [Maximum shutter], [Pedestal level]
2. Adjust the color
  - [White balance], [Chroma gain level]
3. Remove the noise
  - [Digital noise reduction], [Sharpness level]



Refer to the User Manual for details of each function.



- The image quality adjustment function may affect each other.
- If necessary, adjust the brightness level of the screen.

## 6.5 Adjusting object brightness (bright scenes)

### 6.5.1 Adjusting brightness

Adjust the object brightness.

- Live image pages configuration panels>Clicking the [Image quality] tabs enables you to set the image quality.
- 1. Adjust the [Brightness] of [Image quality]
  - Moving in the [+] direction brightens the image.
  - Move in the [-] direction to darken the image.

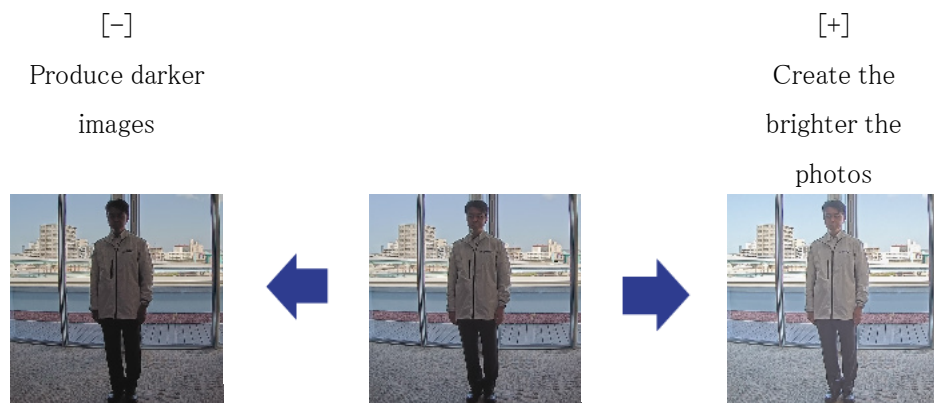

## 6.6 Adjusting object brightness (dark scenes)

### 6.6.1 Adjust the maximum gain

In dark scenes, the image becomes brighter by increasing the maximum gain.

- Live image pages configuration panels>Clicking the [Image quality] tabs enables you to set the image quality.
- 1. Adjust the [Maximum gain] to [+]

Maximum gain: 6

Maximum gain: 11

## 6. Other

### 6.7 Reducing white flickering and blacking on the screen

---

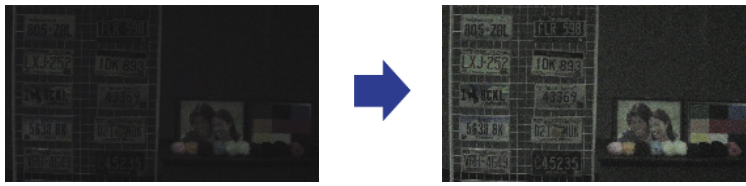

Increasing the maximum gain increases noise.

#### 6.6.2 Adjust the maximum shutter

Increasing the maximum shutter makes the images brighter.

➤ Live image pages configuration panels>Clicking the [Image quality] tabs enables you to set the image quality.

1. Select [Maximum shutter]

- Selecting [Maximum shutter] longer than [Max 1/30s] brightens the image because the amount of light entered increases.



Increasing the maximum shutter increases the blur.

Maximum shutter : 1/30



Maximum shutter : 4/30



## 6.7 Reducing white flickering and blacking on the screen

### 6.7.1 Set Super Dynamic

When Super Dynamic is set to ON, both bright and dark areas are reproduced faithfully, even when shooting in a place with a large brightness difference.

## 6. Other

### 6.7 Reducing white flickering and blacking on the screen

---

- Live image pages configuration panels>Clicking the [Image quality] tabs enables you to set the image quality.

1. Set [Super Dynamic] to [On]



Set [Super Dynamic] to [Off] when the following phenomena are observed depending on the lighting condition.

- If flicker or color change occurs
- Noise in the bright area on the screen

Super Dynamic: Off



Super Dynamic: On



#### 6.7.2 Set the backlight compensation

By setting [Backlight Corrector], the darkness of the indoor object is suppressed (brighter indoor object).

- Live image pages configuration panels>[Detail setting]>[Camera detailed setting]>[Image] or [Image/Audio] of the Advanced menus on the left>[Image adjust] in the [Image quality] tabs>When [Advanced settings] is clicked, the image quality adjustment setting window is displayed.

1. Set to [Back light compensation(BLC)] in the [Super Dynamic] [BLC/ HLC]



If [Super Dynamic] is set to [On] or [Intelligent Auto] is set to [On], [Backlight Compensation] cannot be set.

Back Light Correction: Off

Back light correction: On

Level: 16

## 6. Other

### 6.7 Reducing white flickering and blacking on the screen

---

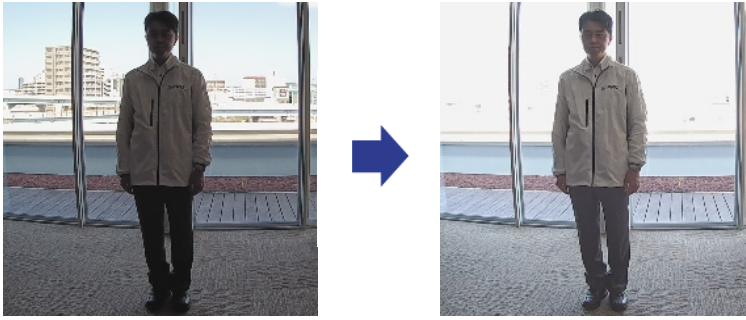

#### 6.7.3 Set the high light compensation

By setting [High light compensation(HLC)], bright lights such as car headlights suppress the brightness of the object.

- Live image pages configuration panels>[Detailed setting]>[Camera detailed setting]>[Image] or [Image/Audio] of the Advanced menus on the left>[Image adjust] in the [Image quality] tabs>When [Setup] is clicked, the image quality adjustment setting window is displayed.

1. Select [High light compensation(HLC)] in [Super Dynamic] [BLC/ HLC]



If [Super Dynamic] is set to [On] or [Intelligent Auto] is set to [On], it cannot be set to [High light compensation(HLC)].

High light compensation :

Off

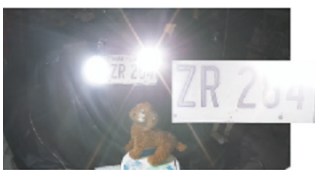

High light compensation :

On



#### 6.7.4 Adjust the adaptive black stretch

Adjust the [Adaptive black stretch] to brighten the dark areas of the images.

- Live image pages configuration panels>[Detail setting]>[Camera detailed setting]>[Image] or [Image/Audio] of the Advanced menus on the left>[Image adjust] in the [Image quality] tabs>When [Advanced settings] is clicked, the image quality adjustment setting window is displayed.

1. Adjust [Detail setting] [Adaptive black stretch] levels to [+]

## 6. Other

### 6.8 Adjust the object contrast

---

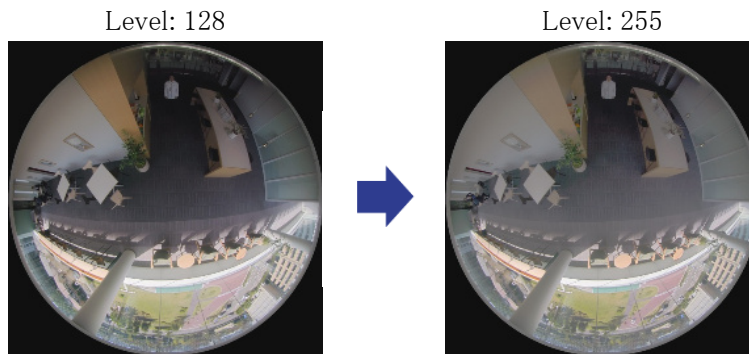

#### 6.7.5 Adjust the [Pedestal level]

Adjust the [Pedestal level] to adjust the black level of the image.

- Live image pages configuration panels>[Detailed setting]>[Camera detailed setting]>[Image] or [Image/Audio] of the Advanced menus on the left>[Image adjust] in the [Image quality] tabs>When [Setup] is clicked, the image quality adjustment setting window is displayed.

##### 1. Adjust the pedestal level of the [Detailed setting].

- Moving in the [+] direction brightens the image.
- Move in the [-] direction to darken the image.



## 6.8 Adjust the object contrast

### 6.8.1 Adjust the contrast

By adjusting the [Contrast level] to increase the contrast between the light and dark images, visibility of the object with less contrast can be improved.

- Live image pages configuration panels>[Detailed setting]>[Camera detailed setting]>[Image] or [Image/Audio] of the Advanced menus on the left>[Image adjust] in the [Image quality]

## 6. Other

### 6.10 Reducing the blur of object (bright scenes)

---

tabs>When [Setup] is clicked, the image quality adjustment setting window is displayed.

1. Adjust [Detailed setting] [Contrast level] levels to [+]

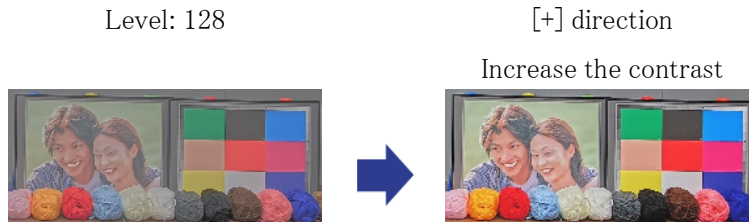

## 6.9 Reduce flicker

Flickers are automatically corrected by using [Light control mode].

- Live image pages configuration panels>Clicking the [Image quality] tabs enables you to set the image quality.
1. Select [Indoor scene (50 Hz)] or [Indoor scene (60 Hz)] for [Light control mode].
    - Use 50 Hz/60 Hz depending on the region.

## 6.10 Reducing the blur of object (bright scenes)

### 6.10.1 Set intelligent auto

Using [Intelligent auto], the camera identifies object with scenes (backlights, outdoors, night scenes, etc.) and facial movements. The camera automatically adjusts the amount, gain, shutter speed, and contrast of light entering the camera from the camera's lenses to make it easier to see a moving object.

- Live image pages configuration panels>[Detailed setting]>[Camera detailed setting]>[Image] or [Image/Audio] of the Advanced menus on the left>[Image adjust] in the [Image quality] tabs>When [Setup] is clicked, the image quality adjustment setting window is displayed.
1. Turning [Intelligent auto] [On] reduces object blur.

6. Other

6.10 Reducing the blur of object (bright scenes)

---



Increased noise when used in low illumination environment.

Off (person blurred)



On (less blurring)



### 6.10.2 Adjust the maximum shutter

Shortening the maximum shutter reduces blur.

➤ Live image pages configuration panels>Clicking the [Image quality] tabs enables you to set the image quality.

1. Selecting a shorter [Maximum shutter] than [Max 1/30s]

- If [Maximum shutter] is set to a shorter time than [Max 1/30s], blur is reduced.



In low illumination environments, shortening the maximum shutter will darken the object and increase the noise.

Maximum shutter :  
1/30



Maximum shutter :  
1/250

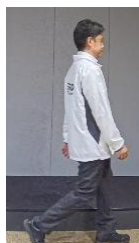

## 6.11 Reducing object blur (dark scenes)

### 6.11.1 Adjust digital noise reduction

Reducing the effects of noise reduction by adjusting the [Digital noise reduction] reduces the blur.

➤ Live image pages configuration panels>Clicking the [Image quality] tabs enables you to set the image quality.

1. Adjust the [Digital noise reduction] in the [-] direction.



If the effect of noise reduction is reduced, the noise will increase.

Level: 128



Level: 100

Reduce the blur



## 6.12 Sharpen the outline of the subject

### 6.12.1 Adjust the sharpness level

Adjust the [Sharpness level] to sharpen the outline of the images.

➤ Live image pages configuration panels>Clicking the [Image quality] tabs enables you to set the image quality.

1. Adjust the [Sharpness level] to [+]

Level: 10

Level: 31

Sharpen the outline of the image

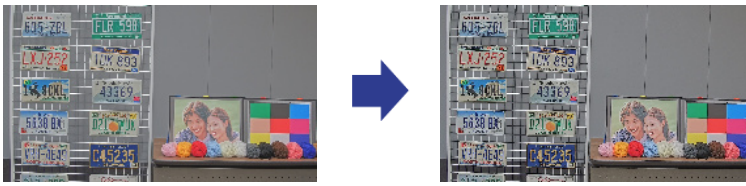

## 6.13 Adjust the color

### 6.13.1 Adjust color density

Adjust the [Chroma gain level] to adjust the darkness.

➤ Live image pages configuration panels>[Detailed setting]>[Camera detailed setting]>[Image] or [Image/Audio] of the Advanced menus on the left>[Image adjust] in the [Image quality] tabs>When [Setup] is clicked, the image quality adjustment setting window is displayed.

1. Adjust [Chroma gain level] in [Basic Adjustment] or [Detailed setting]
  - If you move the slider in the “+” direction, the colors will become loud and vivid.
  - If you move the slider in the “-” direction, the colors will become subdued.

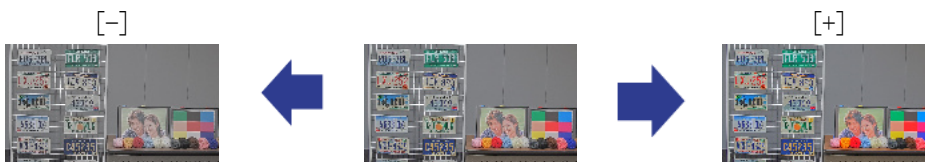

### 6.13.2 Adjust the white balance

If the color is affected by a sodium lamp, use [White balance] to adjust the color.

➤ Live image pages configuration panels>[Detailed setting]>[Camera detailed setting]>[Image] or [Image/Audio] of the Advanced menus on the left>[Image adjust] in the [Image quality] tabs>When [Setup] is clicked, the image quality adjustment setting window is displayed.

1. Select [ATW2] in [White balance]
  - The camera automatically adjusts the white balance under a sodium lamp.

Effect of sodium lamp

No effect of sodium lamp

6. Other

6.15 Reducing object noise (dark scenes)

---

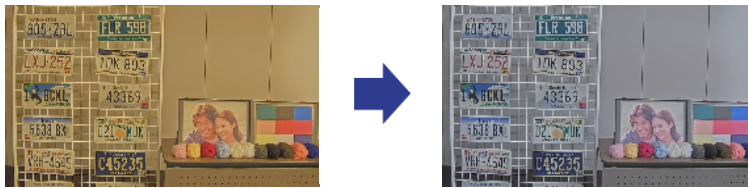

## 6.14 Reducing object noise (bright scenes)

### 6.14.1 Adjust the sharpness level

Adjusting the [Sharpness level] to make the images soft reduces the noise around the object.

➤ Live image pages configuration panels>Clicking the [Image quality] tabs enables you to set the image quality.

1. Adjust the [Sharpness level] in the [-] direction.

Level: 31

Level: 5

Soften the outline of the image



## 6.15 Reducing object noise (dark scenes)

### 6.15.1 Adjust digital noise reduction

By adjusting the [Digital noise reduction] and increasing the effects of noise reduction, noise is reduced.

➤ Live image pages configuration panels>Clicking the [Image quality] tabs enables you to set the image quality.

1. Adjust the [Digital noise reduction] to [+]

## 6. Other

### 6.16 Set focus when switching between black and white.

---



Increasing the effects of noise reduction increases blur.

Level: 90



Level: 255

Reduce noise

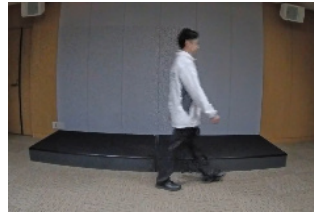

## 6.16 Set focus when switching between black and white.

### 6.16.1 Focus adjustment method for switching between black and white

If spots such as street lights or flat object are reflected in low-illumination conditions, the focus may not match when switching between black and white. If this is the case, adjust the focus as shown below.

- Live image pages configuration panels>[Detail setting]>[Camera detailed setting]>[Image/Audio] of the Advanced menus on the left>[Zoom/focus adjustment] in the [Image quality] tabs>To Advanced Settings>>Click [Zoom/Focus Adjustment] to open the Zoom/Focus Setting window.
  1. Change [Focusing at Day & Night switching] to [Preset]
  2. Run [Manual focus adjustment] or [Auto focus] in color
    - The focus position is stored in the color mode during daytime shooting.
  3. Run [Manual focus adjustment] or [Auto focus] in black and white
    - The focus position is stored in black and white during night shooting.
- Live image pages configuration panels>[Detail setting]>[Camera detailed setting]>[Image/Audio] of the Advanced menus on the left>[Image adjust] in the [Image quality] tabs>To Advanced Settings>>Click [Image Quality Adjustment] to display the image quality adjustment setting screen.
  4. Set the [D&N] to [Auto1(IR Light Off)], [Auto2(IR Light On)], or [Auto3(SCC)] for your

application



To be black-and-white during the daytime, set [Day & Night(IR)] to [On(IR Light On)] and force it to black-and-white.

## 6.17 Troubleshooting

**Check the symptoms on this table before asking for repair.**

Contact the dealer from whom you purchased the watch if you do not recover from any of these problems or if you have symptoms other than those listed in this table.

Phenomenon	Cause	Countermeasure	See Also
Power does not turn on	For PoE power <ul style="list-style-type: none"> <li>•Complies with the PoE(IEEE802.3af: Is the Ethernet cable of this machine connected to a compatible power supply device?</li> <li>•Depending on the power supply device to which more than one PoE terminal device can be connected, power is not supplied when the total power limit that can be supplied is exceeded.</li> </ul>	<ul style="list-style-type: none"> <li>•Please check if it is connected.</li> <li>•Read the operating instructions for the PoE power supply.</li> </ul>	Installation section
The LINK indicator does not light amber when the network cable	<ul style="list-style-type: none"> <li>•Is the Ethernet cableconnected to the machine correctly?</li> </ul>	<ul style="list-style-type: none"> <li>•Connect the Ethernet cable correctly.</li> </ul>	—

Phenomenon	Cause	Countermeasure	See Also
is connected.	<ul style="list-style-type: none"> <li>•Is the hub or router to which this unit is connected operating properly?</li> <li>•Is the Ethernet cable connected to the machine broken?</li> </ul>	<ul style="list-style-type: none"> <li>•Make sure that the hub or router you are using is operating properly.</li> <li>•Replace the Ethernet with another one.</li> </ul>	
The auto focus (AF) does not match.	Focusing may not be automatically adjusted in the following locations or when the camera is in object. <ul style="list-style-type: none"> <li>•There is a large movement.</li> <li>•Large change in illuminance</li> <li>•Low illumination</li> <li>•Be extremely bright or reflective</li> <li>•Over the window</li> <li>•Places where the lens is easily dirty</li> <li>•Less bright or dark, such as white walls</li> <li>•The flicker is severe.</li> </ul>	Manually adjust the focus from the software screen.	—

## 6.18 Precautions pertaining to usage

- **Impact on image and image quality**

The image quality may deteriorate or the image may not be visible under the following installation conditions.

- When raindrops adhere to the front panel due to wind during rainfall
- Snow adheres to the front panel in the event of snow coverage or wind (the amount of snow

adhered depends on the amount of snow and snow quality).

- When dirt adheres to the front panel due to dust in the air, automobile exhaust, etc.

- **Do not touch the lens or front panel directly.**

If dirty, image quality may deteriorate.

- **Using the Product in a Low Temperature Environment**

The camera may not function properly, if it is installed and operated in an environment where the temperature is below  $-25^{\circ}\text{C}$  ( $-13^{\circ}\text{F}$ ). In such a case, wait approximately 2 hours or more until the camera is warmed up. Then, turn on the power again.

As the camera warms up, snow or frost accumulated on the front panel will melt. However, it may not be defrosted from the cover depending on the ambient temperature or weather condition.

- **Batteries**

The battery is built into this product. Do not leave the battery in an environment exposed to excessive heat from sunlight or fire.

- **If this product is no longer in use, do not leave it unattended and must be removed.**

- **We shall not be liable for content compensation, losses of recorded or edited content and any direct or indirect consequent damages caused by failure to record or edit due to faults with this unit or the microSD memory card.**

In addition, the same provisions apply after unit is repaired.

- **Open Source Software**

- This product contains open source software licensed under GPL (GNU General Public License), LGPL (GNU Lesser General Public License), etc.
- Customers can duplicate, distribute and modify the source code of the software under license of GPL and/or LGPL.
- For details concerning licensing and source code of open source software, click “Click here for OSS information” on “Support” page of the setup menu of this product and read the displayed content.
- Please note that we shall not respond to any inquiries regarding the contents of the source code.

- **Copyright**

Except for open source software licensed under GPL/LGPL and so on, distributing, copying, disassembling, reverse compiling and reverse engineering of the software provided with this product are all expressly prohibited. In addition, exporting any software provided with this product violating export laws is prohibited.

## 6.19 Disclaimer

IN NO EVENT SHALL i-PRO Co., Ltd. BE LIABLE TO ANY PARTY OR ANY PERSON, EXCEPT FOR REPLACEMENT OR REASONABLE MAINTENANCE OF THE PRODUCT, FOR THE CASES, INCLUDING BUT NOT LIMITED TO BELOW:

1. ANY LOSS OR DAMAGE, INCLUDING WITHOUT LIMITATION, DIRECT OR INDIRECT, SPECIAL, CONSEQUENTIAL OR EXEMPLARY, ARISING OUT OF OR RELATING TO THE PRODUCT;
2. ANY INCONVENIENCE, LOSS, OR DAMAGE CAUSED BY INAPPROPRIATE USE OR NEGLIGENT OPERATION OF THE USER;
3. ALL MALFUNCTIONS OR TROUBLES FROM UNAUTHORIZED DISASSEMBLE, REPAIR OR MODIFICATION OF THE PRODUCT BY THE USER, REGARDLESS OF THE CAUSE OF THE MALFUNCTION OR TROUBLE;
4. INCONVENIENCE OR ANY LOSS ARISING WHEN IMAGES ARE NOT DISPLAYED, DUE TO ANY REASON OR CAUSE INCLUDING ANY FAILURE OR PROBLEM OF THE PRODUCT;
5. ANY PROBLEM, CONSEQUENTIAL INCONVENIENCE, OR LOSS OR DAMAGE, ARISING OUT OF THE SYSTEM COMBINED BY THE DEVICES OF THIRD PARTY;
6. ANY CLAIM OR ACTION FOR DAMAGES BROUGHT BY ANY PERSON OR ORGANIZATION AS A PHOTOGRAPHED SUBJECT DUE TO VIOLATION OF PRIVACY CONCERNING A SURVEILLANCE CAMERA'S PICTURE OR SAVED DATA, FOR SOME REASON (INCLUDING USE WHEN USER AUTHENTICATION ON THE AUTHENTICATION SETTING SCREEN IS SET TO OFF), BECOMING PUBLIC OR BEING USED FOR ANY PURPOSE;
7. LOSS OF REGISTERED DATA CAUSED BY ANY FAILURE (INCLUDING INITIALIZATION OF THE PRODUCT DUE TO FORGOTTEN AUTHENTICATION INFORMATION SUCH AS A USER NAME AND PASSWORD);

### **Limitation of liability**

THIS PUBLICATION IS PROVIDED "AS IS" WITHOUT WARRANTY OF ANY KIND, EITHER EXPRESS OR IMPLIED, INCLUDING BUT NOT LIMITED TO, THE IMPLIED WARRANTIES OF MERCHANTABILITY, FITNESS FOR ANY PARTICULAR PURPOSE, OR NON-INFRINGEMENT OF THE THIRD PARTY'S RIGHT.

THIS PUBLICATION COULD INCLUDE TECHNICAL INACCURACIES OR TYPOGRAPHICAL ERRORS. CHANGES ARE ADDED TO THE INFORMATION HEREIN, AT ANY TIME, FOR

THE IMPROVEMENTS OF THIS PUBLICATION AND/OR THE CORRESPONDING PRODUCT (S).

## 6.20 For trademarks and registered trademarks

- Microsoft, Microsoft Edge, and Windows are trademarks of the Microsoft group of companies.
- Intel and Intel Core are trademarks of Intel Corporation or its subsidiaries.
- Adobe, Acrobat, and Reader are either registered trademarks or trademarks of Adobe in the United States and/or other countries.
- Google Chrome is a trademark of Google LLC.
- Firefox is a trademark of the Mozilla Foundation in the US and other countries.
- The SD logo, microSD logo and microSDXC logo are trademarks of SD-3C, LLC.
- Other company names and product names described in this manual are trademarks or registered trademarks of each company.

## 6.21 NETWORK RELATIONSHIP

Since this product is connected to the network, it may be damaged as follows.

- ① Leakage or leakage of information via this product
- ② Malicious operation of this product by a malicious third party
- ③ Interference or stoppage of this product by a malicious third party

In order to prevent such damage, take adequate network security measures including the following measures under the responsibility of the customer.

- Use this product on a secure network using firewalls, etc.
- Confirm that computer viruses and malicious programs are regularly checked and exterminated when the computer is connected to the system.
- Use user authentication, set user names and passwords, and restrict users who can log in to protect against unauthorized attacks.
- To prevent image data, authentication information (user name, password), alarm mail information, FTP server information, DDNS server information, etc., from being leaked on the network, measures such as restricting access by user authentication are implemented.
- All browsers must be closed after administrator access to this product.

## 6. Other

### 6.21 NETWORK RELATIONSHIP

---

- The password of the administrator is changed periodically. In addition, authentication information (user name, password) shall be appropriately stored so that it is not visible to third parties.
- Do not install this product or cables in a place where they are easily destroyed.