

ii·PRO

Installation Guide

Extension Unit

Model No. **WJ-HXE410 Series**

For professional use only

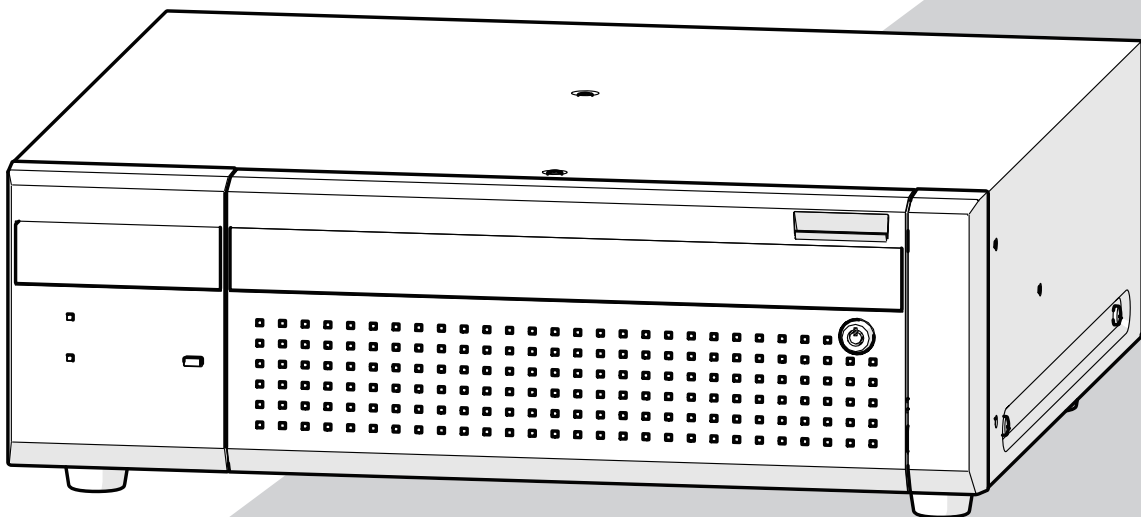

WJ-HXE410 Series refer to WJ-HXE410, WJ-HXE410G and WJ-HXE410GV.

The Operating Instructions and Important Information is on our support website (https://i-pro.com/global/en/surveillance/documentation_database).

Before attempting to connect or operate this product, please read these instructions carefully and save this manual for future use.

The model number is abbreviated in some descriptions in this manual.

Contents

Introduction	3
Standard accessories	3
About the user manuals	3
About the symbol mark.....	3
About HDD Unit	4
Precautions for installation.....	4
Operations flow	6
Installation flow	6
About the operation	6
1 Rack mounting	7
Installation procedure.....	7
Position in the Rack	8
2 Connection	9
3 Turn on the devices	11
Turn on the power of the extension unit	11
(When turn off the power of the extension unit).....	11
4 Assemble HDD unit	12
5 Installation of HDD unit	13
Troubleshooting	14

Important Information

Refer to the Important Information on our support website for the following items.

Safety Information	• Important safety information
Introduction	• Preface • Disclaimer of warranty
Precautions	• Precautions for use
Major operating controls	• Major operating controls and their functions
HDD unit	• Handle the HDD unit • Install the HDD unit in extension unit • Remove the HDD units from extension unit • Remove the extension unit from recorder
Others	• Specifications

Introduction

Standard accessories

Installation Guide	1 pc.	Rack mounting bracket fixing screw	6 pcs.
Power Cord (WJ-HXE410)	1 pc.	Rack handle	2 pcs.
Power Cord (WJ-HXE410G)	2 pcs.	Screws for the rack handle	4 pcs.
Power Cord (WJ-HXE410GV)	1 pc.	Washer	4 pcs.
Label*1	1 pc.	HDD canister	9 pcs.
Key	2 pcs.	HDD fixing screw	36 pcs.
Connection cable (1.5 m {4 feet 11 inches})	1 pc.	Power cord clamp	1 pc.
Cable clamp	2 pcs.	Spring washer (for future use)	36 pcs.
Rack mounting bracket	2 pcs.		

*1 This label is the same one found on the surface of this product. Keep it in view when installing this product in the rack.

About the user manuals

This manual describes how to install, connect, and install the HDD unit of the WJ-HXE410 Series (hereafter this product or extension unit) using an example configuration with an optional network disk recorder (WJ-NX510K Series, WJ-NX410K Series, hereinafter recorder). Also read the manuals of the recorder.









There are 2 manuals provided for this product as follows.

Installation Guide (this book):	Contains procedures of how to install/connect this product with devices.
Important Information:	Contains preface, precautions, and major operating controls and their functions and specifications.
	Refer to our support website (https://i-pro.com/global/en/surveillance/documentation_database).

The external appearance in the document may differ from the actual product within no influence range on operation due to improvement of the product.

About the symbol mark

The explanation of the symbol marks used in this product are as follows.

	Alternation current symbol		Computer network		"ON"/"OFF" (push-push)
	Direct current symbol		Mouse port		
	For indoor use only		USB port		
	Polarity of d.c. power connector		Functional earthing;functional grounding (US) symbol		

About HDD Unit

To install a hard disk drive in the recorder, it is necessary to assemble an HDD unit (encase the hard disk drive in the HDD canister). The HDD unit is designed to easily install/remove the hard disk drive in/from the recorder. Contact your dealer about purchasing, installing, and replacing the hard disk drives.

Precautions for installation

This product is designed to be used indoors.

This product is not operable outdoors. Do not expose this product to direct sunlight for hours and do not install the product near a heater or an air conditioner. Otherwise, it may cause deformation, discoloration and malfunction. Keep this product away from water and moisture.

i-PRO Co., Ltd. assumes no responsibility for injuries or property damage resulting from failures arising out of improper installation or operation inconsistent with this documentation or through use of parts other than this product, such as locally procured parts.

Do not place this product in the following places:

- Locations exposed to direct sunlight
- Locations subject to having strong vibration or impact
- Locations near magnetic field sources such as a television or speakers
- Locations near the devices that emit large sound and generate vibration by sound pressure
- Locations where condensation forms easily, where temperature changes greatly or where humidity level is high
- Locations subject to steam and oil smoke such as a kitchen
- Locations which are not level
- Locations subject to dust
- Locations where it may get wet from rain or water splash

Do not install this product in locations where the product or the cables can be destroyed or damaged by persons with malicious intent.

In order to prevent injury, the product must be securely mounted to a wall according to Installation Guide.

Place this product horizontally on a level surface.

Do not place this product in an upright position. When stacking multiple recorders, clear a space of more than 5 cm {2 inches} from both sides, the top, the bottom and the rear of the recorders.

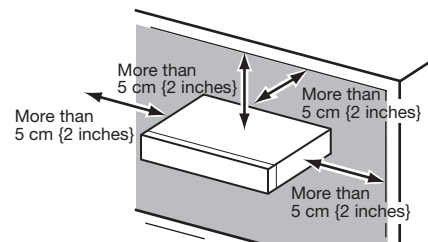

- Do not stack this product in a stack.
- Do not place anything that can generate vibration on the top of this product.

Introduction (continued)

Heat dissipation

To prevent this product from overheating, heed the following. Failure to observe this may cause fire or trouble.

- Do not block the cooling fan outlet or the ventilation holes with a wall, rack, cloth, etc. Maintain the product periodically to prevent dust from blocking ventilation holes.
- The lifetime of the cooling fan is limited by use. It is recommended to replace them after around 30000 hours of operation. Contact your dealer for replacement of the cooling fans.
- When the internal temperature rises, the fan noise may become louder.
- Clear a space of more than 5 cm {2 inches} from both sides, the top, and the rear of the product. Do not block the ventilation holes on the front side since this product is designed to cool the hard disk drives by drawing in air from the front.

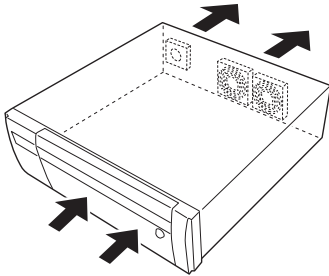

Avoid placing this product near noise sources

If the cables are placed near noise sources such as fluorescent lamps, noises may be produced. In this case, rewire avoiding the noise sources, or move the product to a place far from the source.

Grounding

Confirm that the wire is connected from the SIGNAL GND terminal to earth ground.

A grounding connection must be made before connecting the power plug or this product to the main power supply. When disconnecting the grounding wire, make sure that the power plug of this product is disconnected from the main power supply.

Avoid placing receptacles that contain liquids such as water near this product.

If liquid spills onto this product, it may cause fire or an electric shock.

About sulfuration of rubber products

Do not leave rubber products containing sulfur (packing and rubber feet) close to the recorder or in the same storing box. Sulfur constituent from the rubber products may cause sulfuration corrosion on electrical parts or terminals and defects in the recorder.

Equipment classification and power source indication label

Refer to the indication label on the bottom side of this unit for the equipment classification, power source, and other information.

Operations flow

- Professional knowledge on and experience in network and the HDD are required for the settings and changes of the operation.
- The PC is required for reading the Important Information.

Installation flow

The installation flow of the extension unit is as follows.

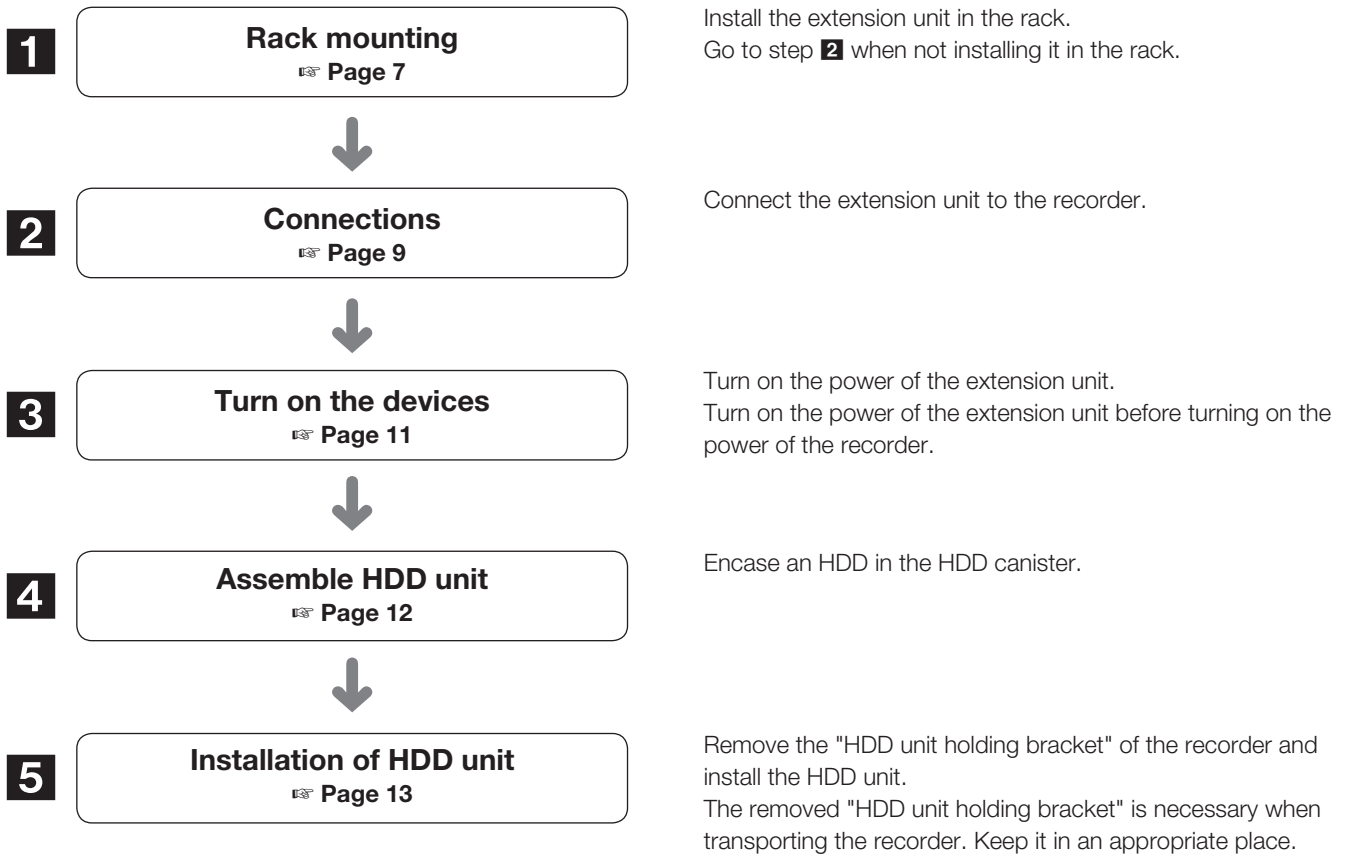

About the operation

The extension unit requires the recorder to set the operational mode of the HDD units or format them. Perform the setting using the connected recorder.

Refer to the Operating Instructions of a corresponding recorder for further information.

1 Rack mounting

Install the recorder in an EIA standard 19-inch rack (Depth: 550 mm or more).

Note:

- Use four M5 × 12 mm screws (locally procured) to install the recorder in a rack.
- The illustration on this page is schematic. Details of the shape are omitted.

Installation procedure

Step 1

Remove the five rubber feet from the bottom of the recorder.

Use a screwdriver to remove the screws holding the rubber feet.

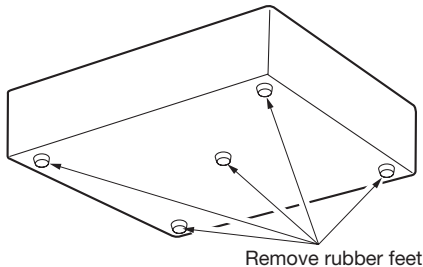

Step 2

Attach the rack handles (included) to the rack mounting brackets (included).

Fix them using the screws (included) (×4) and the washers (included) (×4) for the rack handle.

Tightening torque: 2.0 N·m ~ 2.4 N·m (1.48 lbf·ft ~ 1.78 lbf·ft)

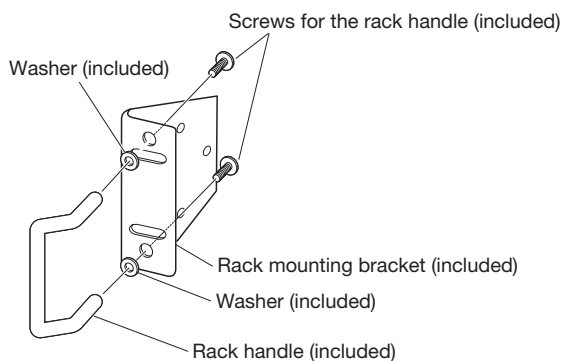

Note:

- The rack mounting bracket (included) has two types of fitting holes to adjust the protrusion of the front rack. Use either of them depending on the installation conditions.

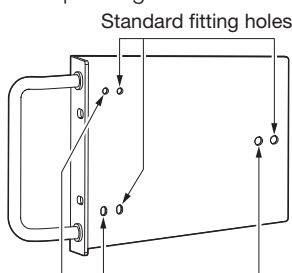

Fitting holes for the front position (about 15 mm {19/32 inches})

Step 3

Place the rack mounting brackets (included) on both sides of the recorder and fix them with the rack mounting bracket fixing screw (included) (×6).

Secure them using the rack mounting bracket fixing screw (included) (×6).

Tightening torque: 0.88 N·m ~ 1.08 N·m (0.65 lbf·ft ~ 0.80 lbf·ft)

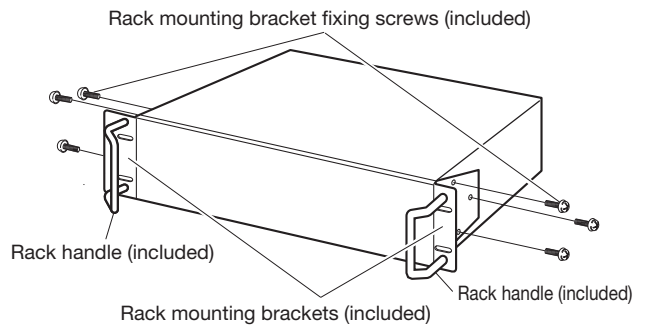

Step 4

Install the recorder in the rack by using four rack mounting screws.

Secure using the rack mounting screws (×4).

Tightening torque: 2.0 N·m ~ 2.4 N·m (1.48 lbf·ft ~ 1.78 lbf·ft)

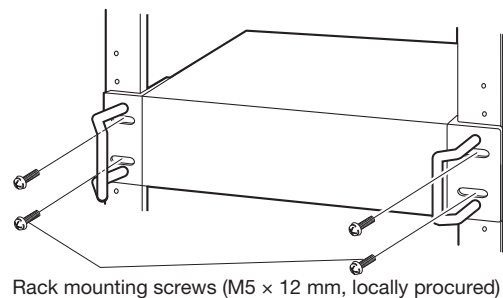

Important:

- The operating temperature range of this product is 0 °C ~ +45 °C {32 °F ~ 113 °F}.
* HDDs deteriorate at high temperatures, affecting their service life. It is recommended that the product be used at a temperature of about +25 °C {77 °F}.
- The following measures should be taken when installing the rack to ensure that the product is used within the operating temperature range.
 - Install a fan or other equipment to lower the temperature inside the rack.
 - Allow a distance of at least 1U (44 mm {1-23/32 inches}) between the top and bottom of the product.
 - Do not put doors on the front of the rack or block the sides.
- The recorder weighs over 10 kg {22.1 lbs}. Be careful not to drop the recorder when installing it into a rack. Dropping may cause damage, deformation of the recorder, or injury.

1 Rack mounting (continued)

Position in the Rack

This is an example where the recorder and the extension unit (max 5 units) are installed in the rack.

Connect the recorder and the extension unit using the connection cable (1.5 m {4 feet 11 inches}) included in the extension unit.

(Page 9)

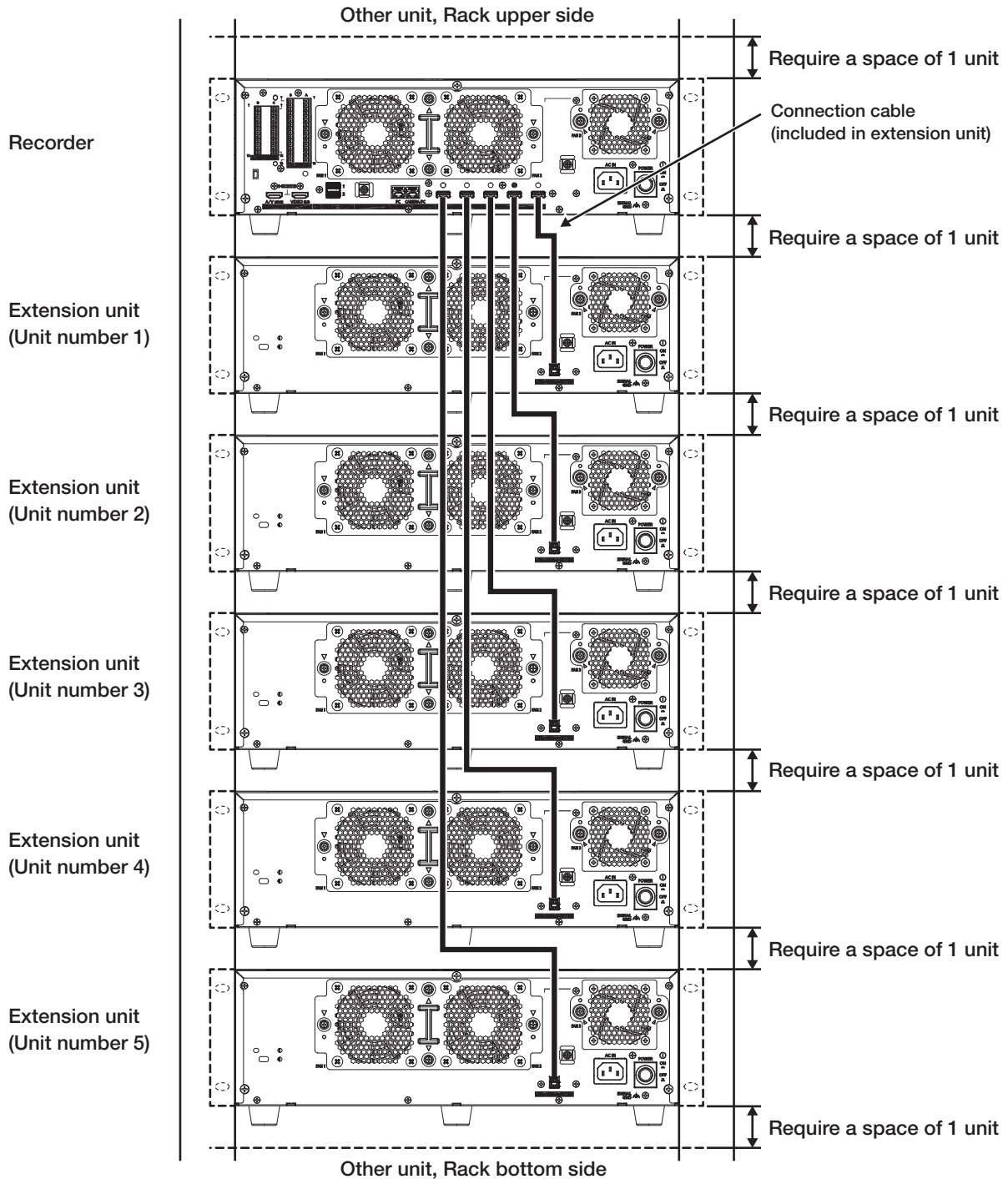

Note:

- When installing the extension unit in the rack, leave a space of 1U (44 mm {1-23/32 inches}) above and below the recorder or the extension unit for ventilation.
- The unit number is the same as the external storage connector number of the recorder.

2 Connection

A separately sold recorder can be mounted with a maximum of 5 units. Connect the extension unit and the recorder using the included connection cable. Fix the connection cable with the included cable clamp so that it does not come off when installing the unit.

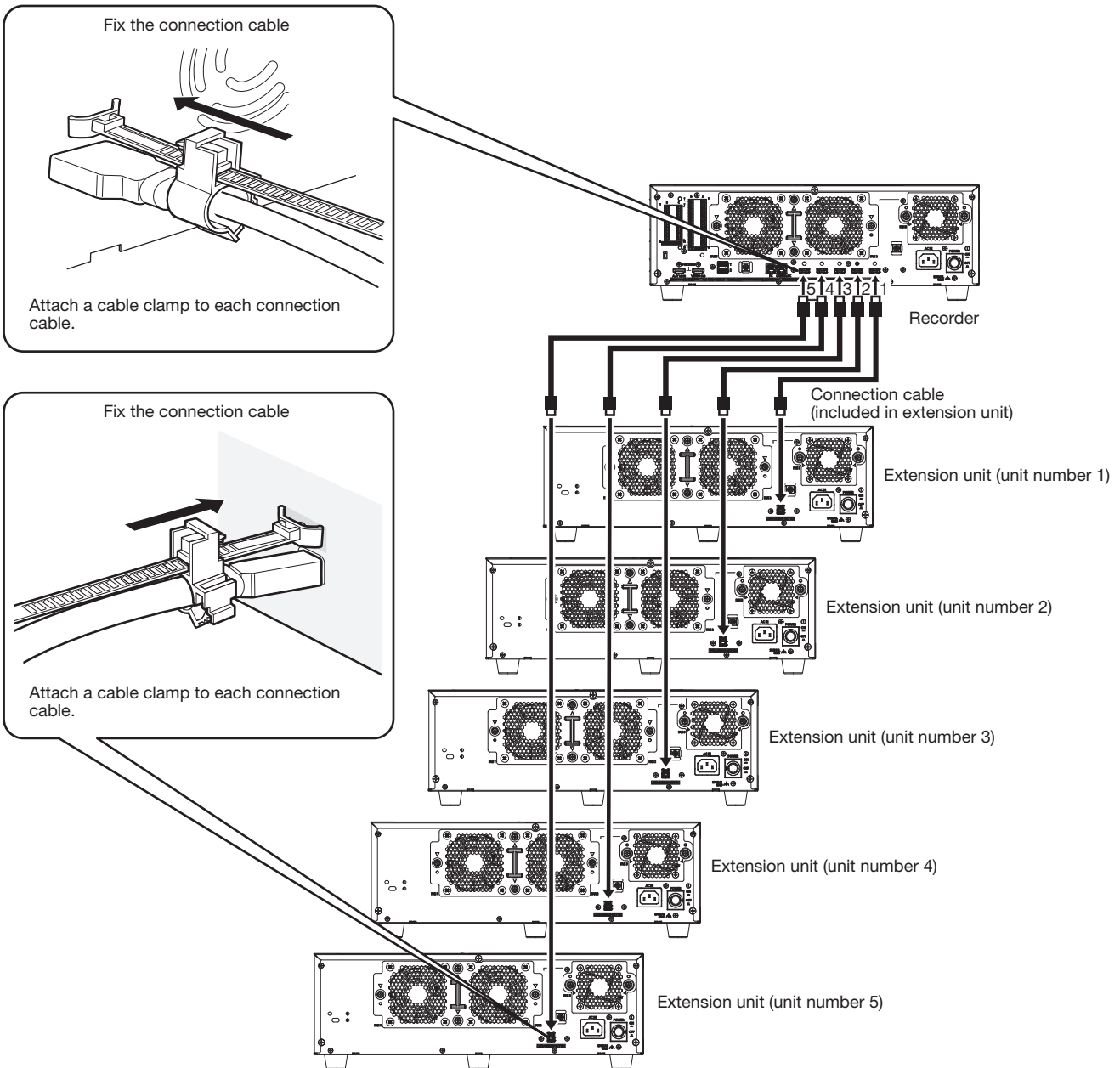

Important:

- Use only the connection cable included in the extension unit when connecting the extension unit and the recorder.
- Fix the connection cable firmly using the cable clamp included in the extension unit (☞ Page 10). When the cable is not connected firmly or when it is disconnected, the system may become unstable or recording may fail.
- Do not wind the cable in a coil.

2 Connection (continued)

Cable clamp

Fix the connection cable using the included cable clamp as follows.

Step 1

Attach the cable clamp fixing belt to the fixing hole on the rear, and attach the holder part of the cable clamp behind the connector end of the connection cable.

Pull the cable clamp fixing belt to confirm that the fixing belt is not pulled out from the rear of the extension unit.

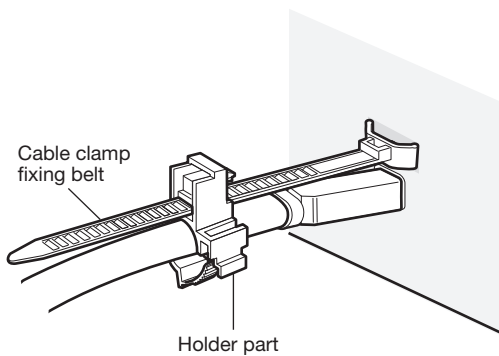

Step 2

Close the clamp.

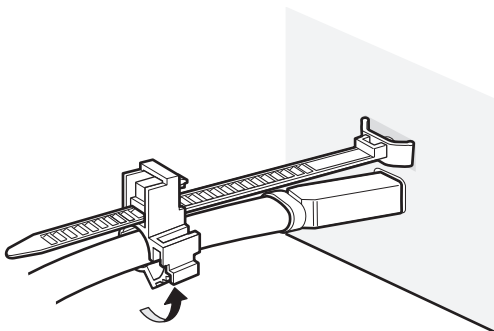

Step 3

Slide the cable clamp toward the connector end of the connection cable, and then hold the connector end of the connection cable.

Make sure that the connection cable is connected firmly.

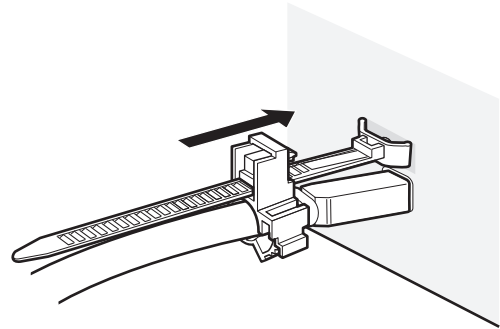

Note:

- Overhead view

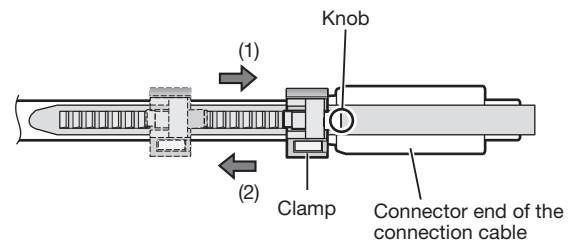

- Hold the connector end of the connection cable by sliding the holder part in the direction of arrow indication (1). If the holder part is not slide all the way to the connector end side, the cable may come out.
- To slide the holder part in the direction of arrow (2), slide it while keeping the knob pulled down.

3 Turn on the devices

Turn on the power of the extension unit

Important:

- Connect the included power source cords to all the extension units and turn them on before turning on the recorder.

Step 1

Connect the included power cord to the power cord inlet on the rear panel of the extension unit, and insert the power plug to an outlet whose rating is as follows.

100 V - 240 V AC, 50 Hz/60 Hz

Important:

- Insert the power cord fully into the power cord inlet so that it will not loosen or come out.
- Fix the power cord firmly at 15 cm to 20 cm {5-7/8 to 7-7/8 inches} from the plug with the included power cord clamp to prevent the cable from unplugging.

How to fix the power cord

Fix the power cord at 15 cm to 20 cm {5-7/8 to 7-7/8 inches} from the connector with the included cable clamp (for power cord) passed through the clamp mount.

Fix the power cord so that it does not block the cooling fan outlet.

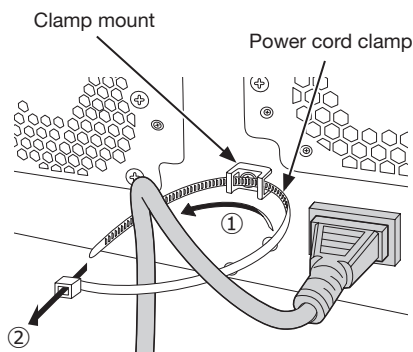

- ① Pass the power cord clamp through the clamp mount.
- ② Make a ring with the power cord clamp as shown in the illustration to tighten the power cord.

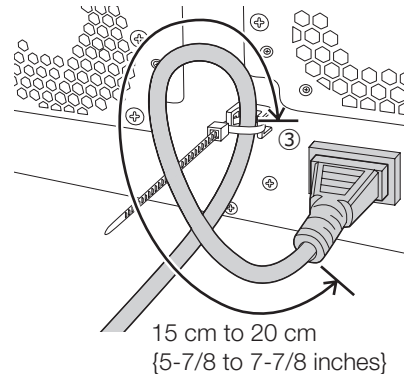

- ③ Tighten the power cord at 15 cm to 20 cm {5-7/8 to 7-7/8 inches} from the connector and fix it to the clamp mount. Cut the unnecessary part of the power cord clamp as necessary.

Step 2

Press the **POWER** switch on the rear of the extension unit to turn on the power.

- The OPERATE indicator will light and the system check (checking the system and hard disk drives) will start.
- The "Initializing" indication will be displayed on the LCD at startup.
- When the system check is complete, the operational mode and temperature will be displayed on the LCD.

(When turn off the power of the extension unit)

Follow the procedure below to turn off the power.

If multiple extension units are connected, turn off them in an arbitrary order.

Step 1

Stop recording on the recorder.

- Stop all recordings on the network disk recorder.
- Stop all playbacks.

Step 2

Turn off the power of the recorder.

Step 3

Turn off the power of the extension unit.

Important:

- Turn off the power of the extension unit after turning off the power of the recorder.

4 Assemble HDD unit

To install a hard disk drive in the recorder, it is necessary to assemble an HDD unit (encase the hard disk drive in the HDD canister).

The HDD unit is designed to easily install/remove the hard disk drive in/from the recorder.

Contact your dealer about purchasing, installing, and replacing the hard disk drives.

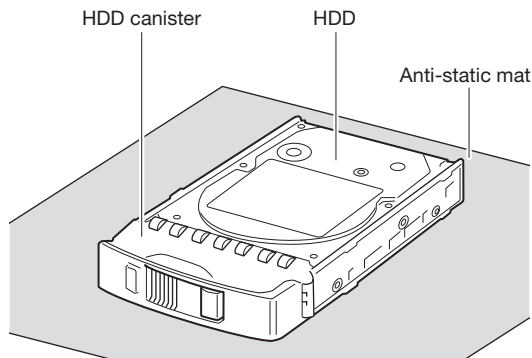

Important:

- Hard disk drives are precision devices. Before installing the hard disk drives, read the "Hard disk drive" section of Precautions in important information together with the following.
 - Before touching a hard disk drive, release static electricity from your body using an anti-static grounding strap, etc.
Even after releasing static electricity, hold the side of the hard disk drive when carrying it. To prevent damage to the hard disk drive from static electricity, do not touch the circuit board and the connectors of the hard disk drive.
 - Use an anti-static mat and an anti-static grounding strap when installing/replacing the hard disk drives.
 - When installing hard disk drives, use a low-torque powered screwdriver or a torque screwdriver to tighten screws with the specified torque.

Step 1

Fix both sides of the hard disk drive with the dedicated HDD canister using the 4 included screws for HDD canister installation.

Tightening torque for the screws: 0.49 N·m (5 kgf·cm) (use a low-torque powered screwdriver or a torque screwdriver)

HDD fixing screws for the HDD canister

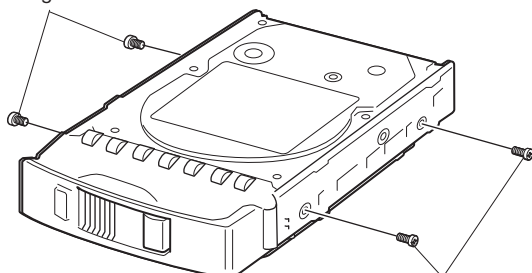

HDD fixing screws for the HDD canister

5 Installation of HDD unit

The illustration on this page is schematic. Details of the shape are omitted.

It is possible to install the HDD units without stopping the operation (except when RAID1/RAID5/RAID6 mode is in operation). Do not use an electric screwdriver to avoid impact on the HDD.

Step 1

After inserting the key (included) into the key hole on the front cover, push and turn it to the right to open the front cover.

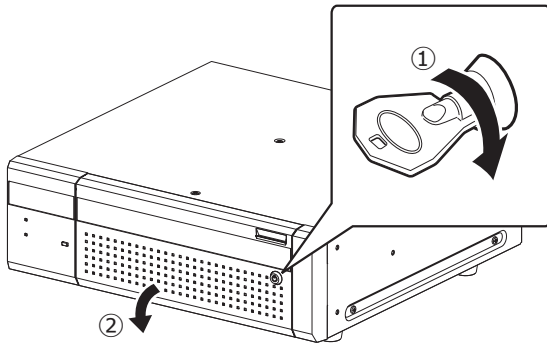

Step 2

Remove the HDD unit holding bracket.

- 1 Remove the fixing screw for bracket.
- 2 Slide the HDD unit holding bracket sideways and remove it.

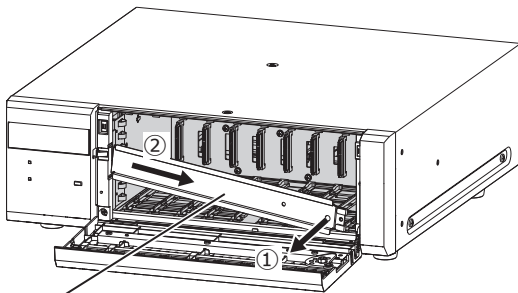

HDD unit holding bracket

- Keep the removed fixing screw for bracket and the HDD unit holding bracket in an appropriate place.

Step 3

Insert the HDD units into the HDD slots in order starting from HDD1.

- 1 Lift up the lever on the HDD unit while holding down the removal knob, and then insert the HDD unit all the way into the HDD slot.
Insert the HDD unit carefully without knocking it against anything (and without knocking against HDD units which are already inserted).
- 2 Push the upper part of the lever securely until it hits the protruding section at the back side of disk slot top and then turn down the lever.
- 3 The removal knob fits into position with a "click" sound when turning down the lever.

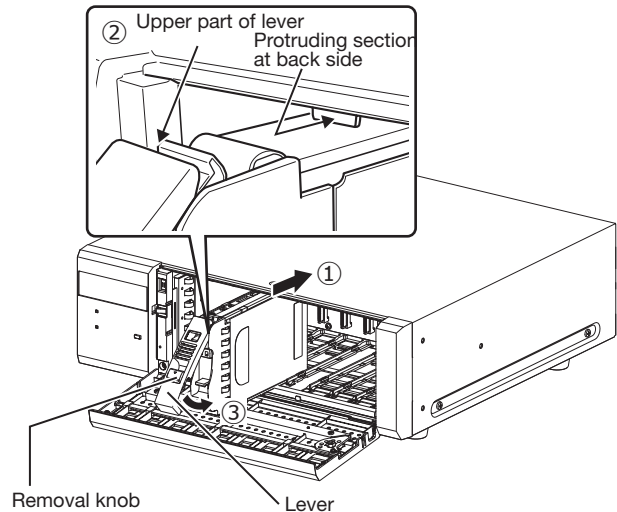

Important:

- Insert the HDD units from the slot number 1.
- When mounting the HDD unit, be careful not to pinch your fingers with the lever.

- 4 The LCD displays as follows.

```
EXT x - y  
NEW HDD DETECT
```

* x is a unit number, y is a slot number

Step 4

Initialize the HDD unit

Refer to the Install Guide of the recorder for initialization the HDD unit.

Troubleshooting

Before asking for repairs, check the symptoms with the following table.

Contact your dealer if a problem cannot be solved even after checking and trying the solution in the table or a problem is not described below.

Symptom	Cause/solution	Ref. pages
Power is not turned on.	<ul style="list-style-type: none"> Is the power plug connected to the outlet firmly? Confirm the cable is firmly connected. 	–
	<ul style="list-style-type: none"> Check if the power cord is properly inserted into the power socket of the extension unit. Check if it is connected firmly. 	11
The "Thermal error" indication is displayed on the main monitor.	<ul style="list-style-type: none"> The ambient operating temperature is 0 °C to +45 °C. The "Thermal error" is displayed based on the internal thermal information of the HDD. If the "Thermal error" indication is displayed, it is recommended to change the installation environment so that the ambient temperature is maintained at approx. +25 °C. When the "Thermal error" indication is displayed frequently, contact your dealer. 	–
	<ul style="list-style-type: none"> Check if the fan is malfunctioning. 	Operating Instructions
	<ul style="list-style-type: none"> Check if the recorder ventilation holes or cooling fan are blocked, and also check for dust collected around the ventilation holes. 	5
The extension unit is not recognized.	<ul style="list-style-type: none"> Make sure that the connection cable provided with the extension unit is being used. 	–
	<ul style="list-style-type: none"> Make sure that the connection cable is not loose. 	–
	<ul style="list-style-type: none"> Was the power of the extension unit turned on before turning on the power of the recorder? Reboot the system and turn on the power of the extension unit first. 	11
	<ul style="list-style-type: none"> When using a circuit breaker or equivalent device to turn on/off the power of the whole system at one time, make sure that all devices are connected to the same power source. 	–
	<ul style="list-style-type: none"> When using an UPS (uninterruptible power system), connect all devices to the same UPS. 	–
The hard disk drive is not recognized. The HDD status indicator does not light.	<ul style="list-style-type: none"> Make sure that the HDD unit is inserted all the way into the HDD slot. 	–
	<ul style="list-style-type: none"> The hard disk drive is faulty. 	–
The HDD access indicator is being lit red/blinking red.	<ul style="list-style-type: none"> Make sure that the HDD units are installed in order from HDD1 to HDD9. 	–
	<ul style="list-style-type: none"> The respective HDD unit is faulty in the RAID1/RAID5 or RAID6 mode. RAID1: the HDD access indicator of the HDD unit in failure will light red. RAID5: the HDD access indicator of the first HDD unit to fail will light red. The HDD access indicator of the second HDD unit to fail will blink red. RAID6: the HDD access indicators of the first and second HDD unit to fail will light red. The HDD access indicator of the third HDD unit to fail will blink red. 	Important Information
Cannot recover data after replacing the HDD units in the RAID1/RAID5/RAID6 mode.	<ul style="list-style-type: none"> Make sure that the HDD unit is inserted all the way into the HDD slot. 	Installation Guide
	<ul style="list-style-type: none"> The hard disk drive on which there is data to be recovered is faulty. 	–
	<ul style="list-style-type: none"> Check if the capacity of the new hard disk drive is smaller than the original one's. 	–
The HDD access indicator blinks orange even when no recording or playback is being performed.	<ul style="list-style-type: none"> Make sure that recovery of data in the RAID1/RAID5/RAID6 mode is not being processed. 	–
The error indicator blinks red.	<ul style="list-style-type: none"> A system error occurred. Contact your dealer. 	–

Troubleshooting (continued)

Symptom	Cause/solution	Ref. pages
The temperature of this product and the temperature of the recorder displayed each on the LCD or system information screen are different.	<ul style="list-style-type: none"> Because the internal structure is different, the displayed temperature will be different even under the same environment. This is not a malfunction. 	–

Inspect the power cord, power plug and connectors periodically.

Symptom	Cause/solution	Ref. pages
The power cord insulation is damaged.	<ul style="list-style-type: none"> The power cord, connector, or power plug is damaged. This may result in electric shock or a fire. Unplug the power plug from the AC outlet immediately, and refer to qualified service personnel. 	–
The power cord, plug and connectors get hot during use.		
The power cord gets hot when bent or stretched.		

Disposal of Old Equipment and Batteries
Only for European Union and countries with recycling systems



These symbols on the products, packaging, and/or accompanying documents mean that used electrical and electronic products and batteries must not be mixed with general household waste.
For proper treatment, recovery and recycling of old products and used batteries, please take them to applicable collection points in accordance with your national legislation.
By disposing of them correctly, you will help to save valuable resources and prevent any potential negative effects on human health and the environment.
For more information about collection and recycling, please contact your local municipality.
Penalties may be applicable for incorrect disposal of this waste, in accordance with national legislation.



Note for the battery symbol (bottom symbol)
This symbol might be used in combination with a chemical symbol. In this case it complies with the requirement set by the Directive for the chemical involved.

For U.S.A.

Disposal may be regulated in your community due to environmental considerations. For disposal or recycling information, please visit our website.

i-PRO Co., Ltd.
Tokyo, Japan
<https://www.i-pro.com/>

Authorised Representative in EU:
i-PRO EMEA B.V.
Laarderhoogtweg 25, 1101 EB
Amsterdam, Netherlands



i-PRO EMEA B.V. UK Branch
1010 Cambourne Business Park,
Cambridgeshire CB23 6DP

