

No.	品名	Part Name	Material	Process-Remark
1	ベース金具	Base bracket	Aluminium die cast	Coating (Light Gray)
2	接続管用めねじキャップ	Cap for the female thread for the conduit	PA	Light Gray
3	銘板	Name plate	Polyester Film	Printing
4	Product dateラベル	Product date label	Polyester Film	Printing
5	シリアルNo.ラベル	Serial number label	Polyester Film	Printing
6				

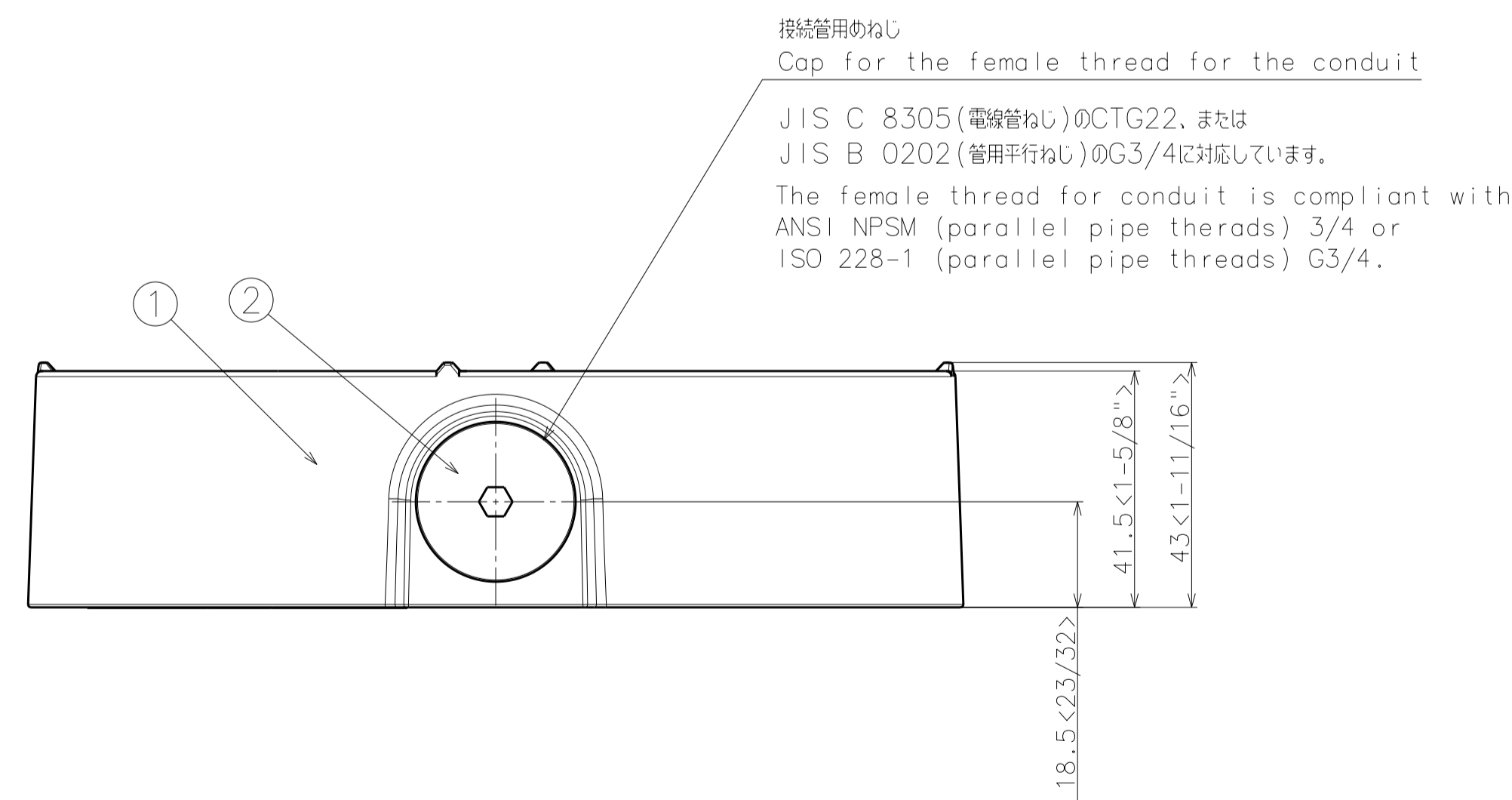
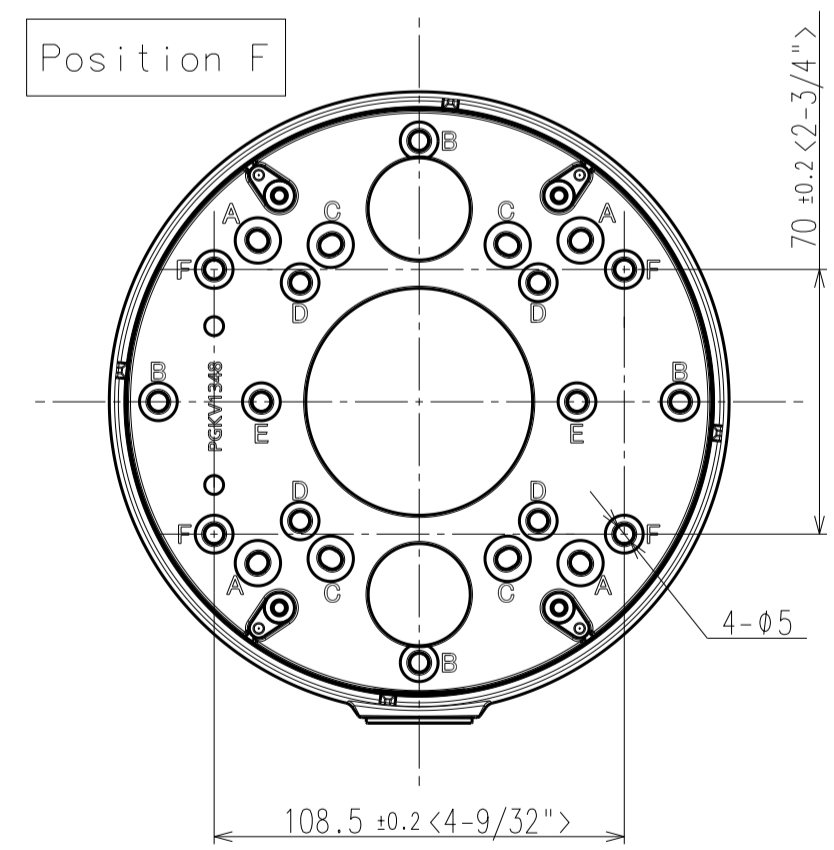
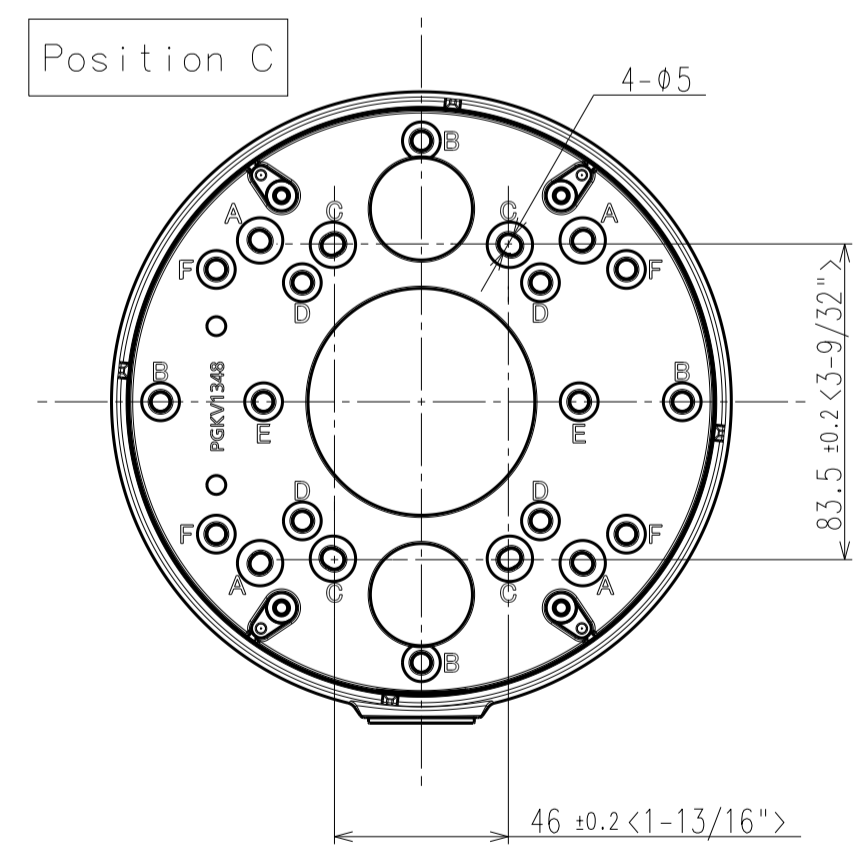
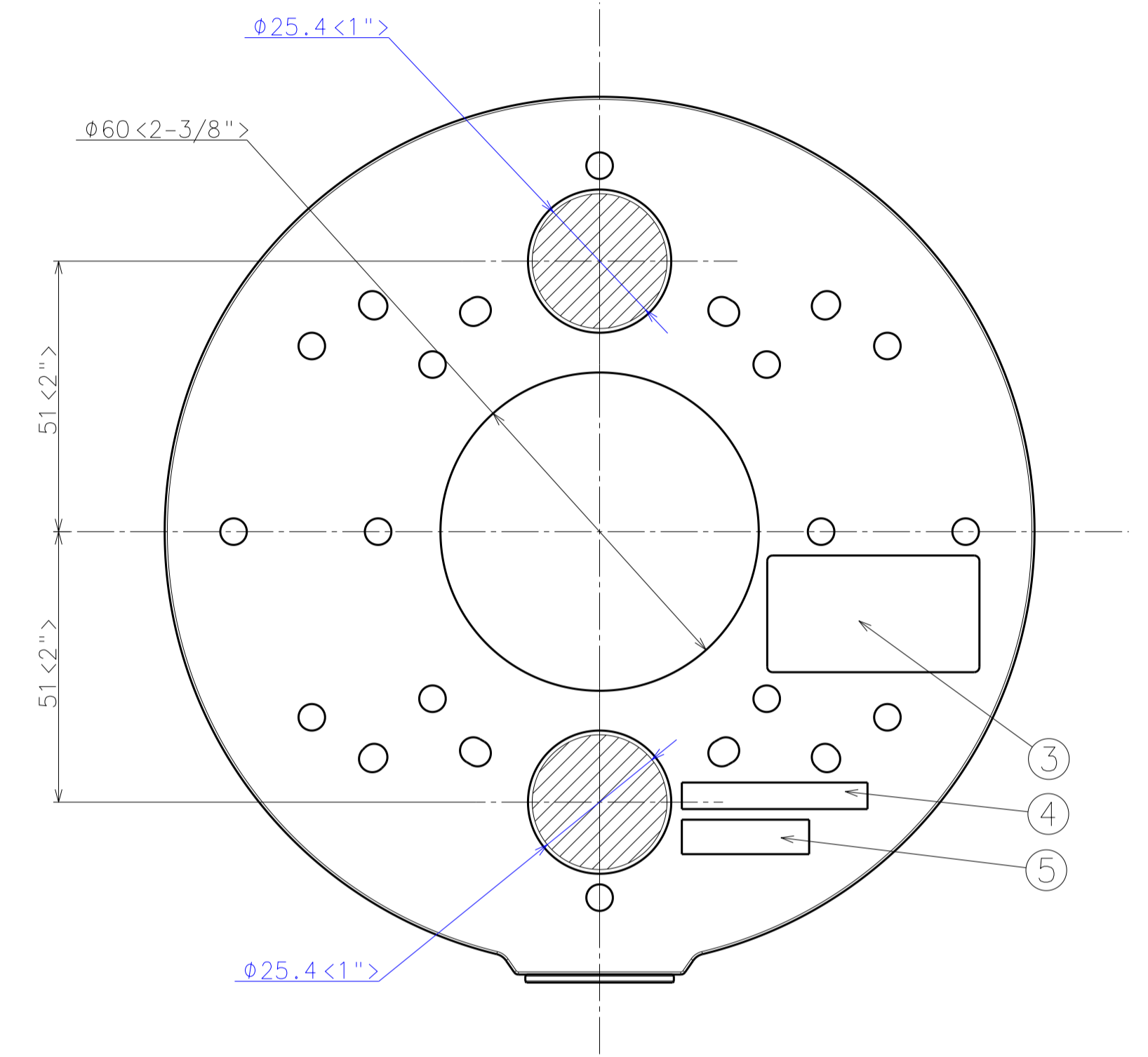
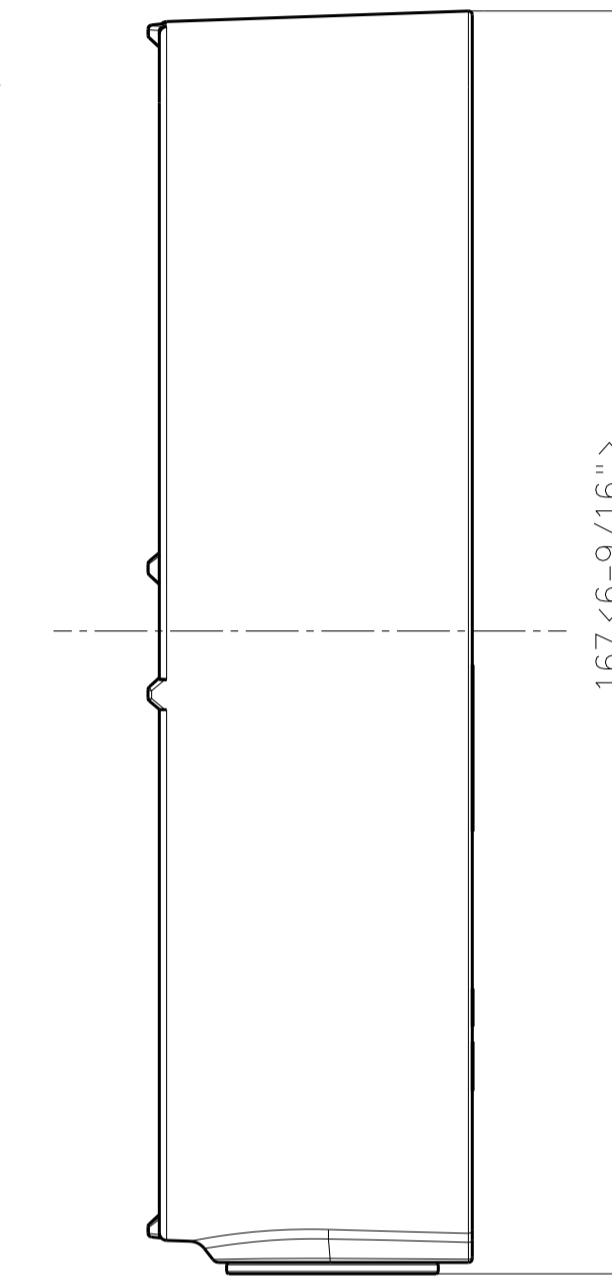
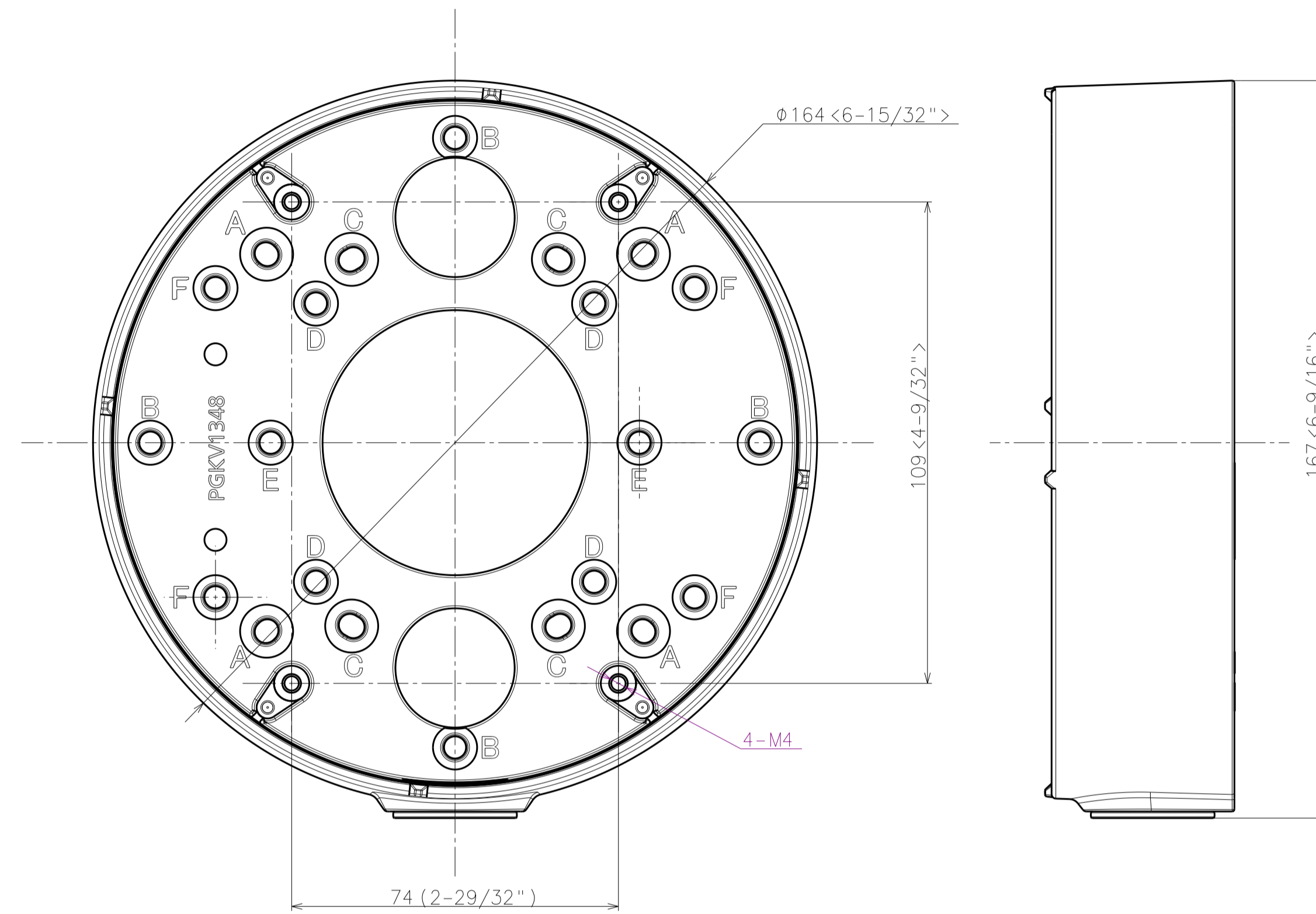
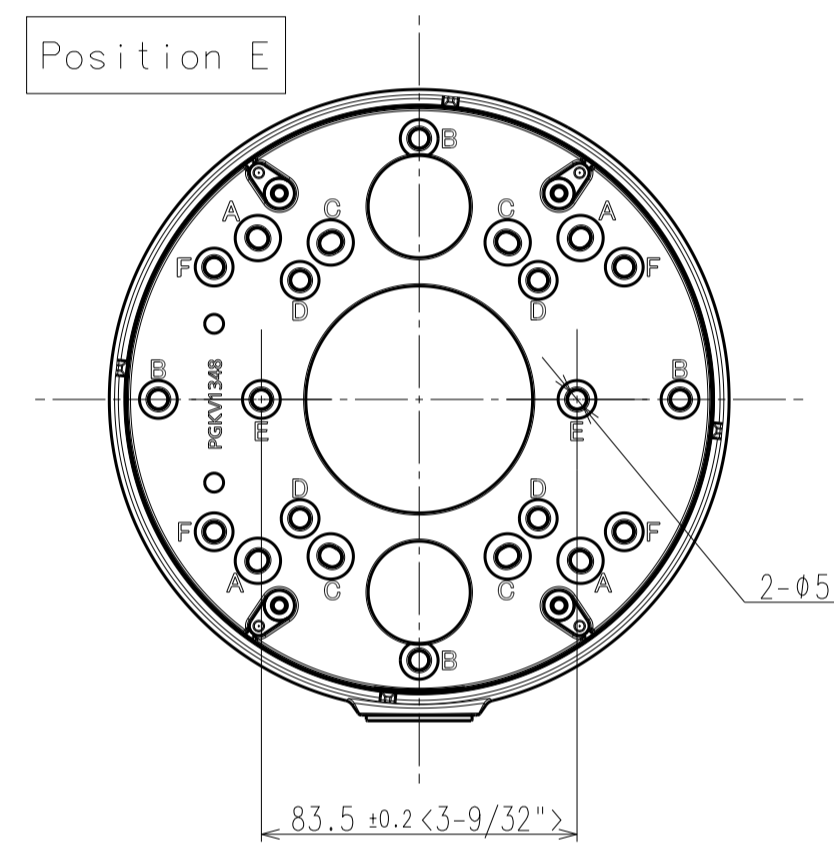
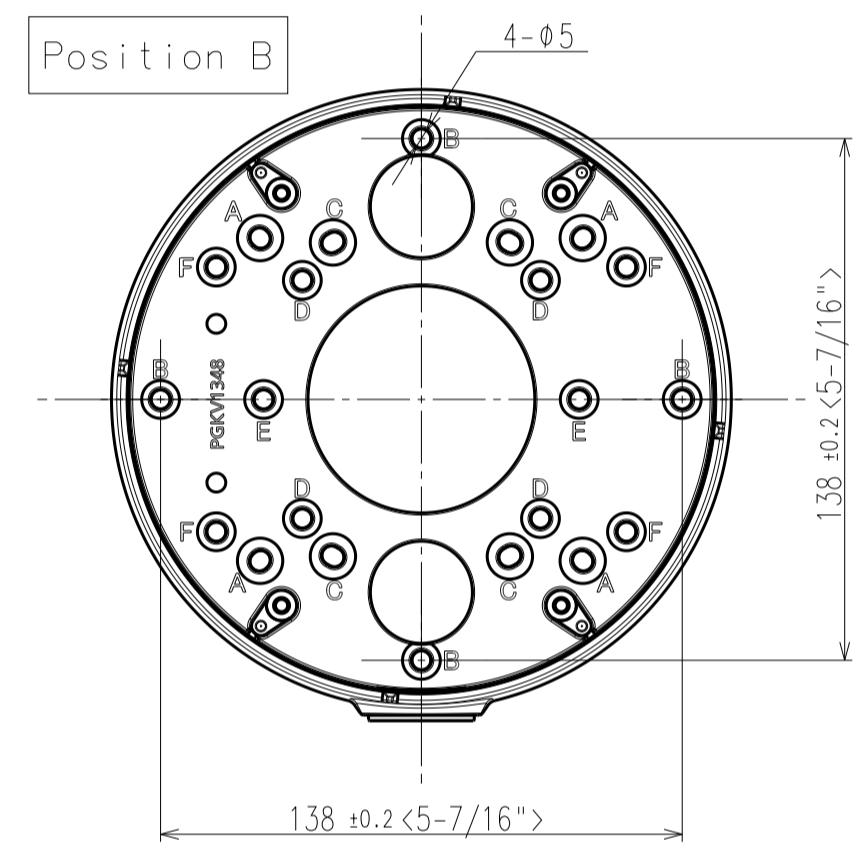
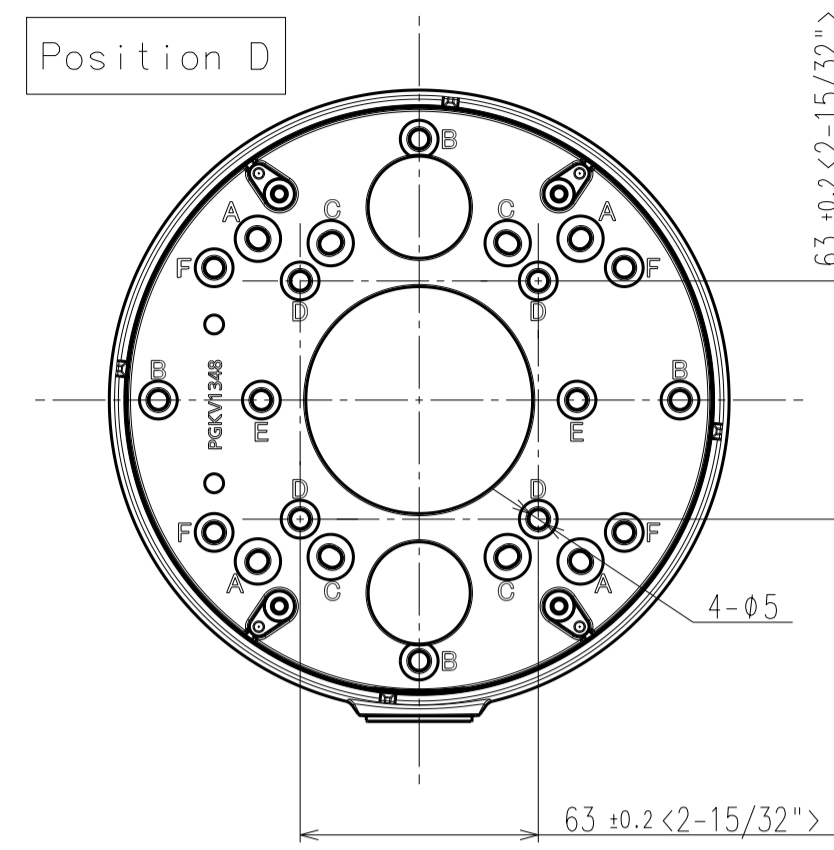
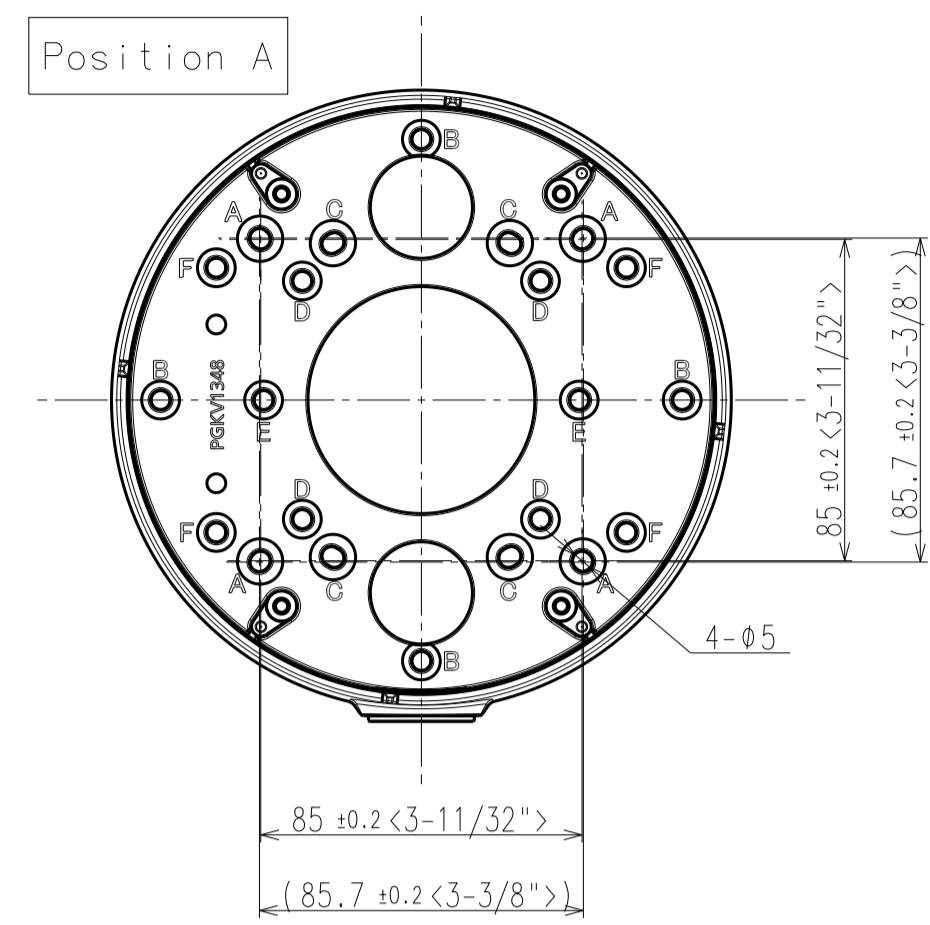

	投影面積 (Projected area)
正面図 / Front-view	0.007 m <sup>2</sup>
側面図 / Side-view	0.021 m <sup>2</sup>
平面図 / Top-view	0.021 m <sup>2</sup>