

## 2MP (1080p) Indoor Dome Network Camera

Panasonic WV-S2131 captures the highest quality images automatically even in very challenging and fast-changing surveillance environments. Intelligent Auto (iA) allows the camera to automatically adjust the key settings in real-time depending on the scenery and movement, reducing distortion such as motion blur and moving objects. New industry-leading 144dB dynamic range delivers balanced scene exposure in dynamic and extreme-backlit lighting environments. In addition, color night vision provides outstanding low-light performance with accurate color rendition and saturation from i-Pro's 1/3" sensor, rivaling the performance of costlier 1/2" sensor cameras in the market. By adopting H.265 Smart Coding technology, intelligently reduces bandwidth efficiency of up to 95%\* more than H.264 for longer recording and less storage. Cameras out-of-the-box, use an encryption module standardized by FIPS Publication 140-2 for secure video streaming.

\*Value in Advanced mode with Smart Facial Coding. It depends on the scene.

### Extreme image quality allows evidence to be captured even under challenging conditions

- Auto Shutter speed control for fast moving object
- Sharp and clear images of a walking person day & night
- Outstanding low light performance in true color with low noise for night time applications
- Super Dynamic 144dB for backlit situations involving headlights and shadows on night streets

### Extreme bandwidth compression with new Panasonic H.265 Smart Coding

- Longer recording and less storage compared to any H.264 based compression techniques
- New self-learning ROI\* encoding (Auto VIQS) detects movement within the image and compresses the areas with little motion in order to reduce transmitted data while maintaining the quality of the image.
- New "Smart Facial Coding" adds more bandwidth reduction for ID camera applications mainly capturing faces

\*Region of Interest

### Extreme Data Security

- Full encryption SD card edge recording to keep your data safe
- FIPS140-2 CAVP compliant \*Using encryption module standardized by FIPS publication 140-2
- Full end-to-end system encryption with supported VMS and devices to protect from IP snooping/spoofing and detect data alteration

### Key Features

- 2MP (1080p) up to 60fps
- iA (intelligent Auto)
- Extreme Super Dynamic 144dB
- Color night vision (0.0008 to 0.012 lx)
- H.265 Smart Coding
- i-VMD License Bundled
- ONVIF® Profile G / S / T

\*ONVIF is a trademark of ONVIF, Inc.

### Industry examples

- Airport (Passport control / Security checkpoint / Ticket counter)
- Retail / Bank / Education / Hospital / Building



# Specifications

<b>Camera</b>	Image Sensor	Approx. 1/3 type MOS image sensor
	Minimum Illumination	Color : 0.012 lx, BW : 0.006 lx (F1.6, Maximum shutter : Off (1/30s), AGC : 11) Color : 0.0008 lx, BW : 0.0004 lx (F1.6, Maximum shutter : max. 16/30s, AGC : 11) <sup>*1</sup>
	White Balance	AWC (2,000 - 10,000 K), ATW1 (2,700 - 6,000 K), ATW2 (2,000 - 6,000 K)
	Shutter Speed	1/30 Fix to 1/10000 Fix <sup>*1</sup> 1/30 Fix to 2/120 Fix is available during 30 fps mode only. <sup>*1</sup> 1/60 Fix is available during 60 fps mode only.
	Intelligent Auto	On / Off
	Super Dynamic <sup>*2</sup>	On / Off. The level can be set in the range of 0 to 31.
	Dynamic Range	Max.144 dB (Super Dynamic : On)
	Adaptive Black Stretch	The level can be set in the range of 0 to 255.
	Back light compensation / High light compensation	BLC (Back light compensation) / HLC (High light compensation) / Off (only when Super dynamic / Intelligent Auto : Off)
	Fog compensation	On / Off (only when Intelligent auto / auto contrast adjust : Off)
	Maximum gain (AGC)	The level can be set in the range of 0 to 11.
	Color/BW (ICR)	Off / On / Auto1 (Normal) / Auto2 (IR Light) / Auto3 (SCC)
	Digital Noise Reduction	The level can be set in the range of 0 to 255.
	Video Motion Detection (VMD)	On / Off. 4 areas available
	Intelligent VMD (i-VMD) <sup>*3</sup>	Type 4 *Bundled License
	Stabilizer <sup>*3</sup>	On / Off (available only in the 30 fps mode)
	Privacy Zone	On / Off. Up to 8 zones available
	Image rotation <sup>*4</sup>	0° / 90° / 180° / 270°
	Camera Title (OSD)	On / Off. Up to 20 characters (alphanumeric characters, marks)
	Focus Adjustment	Auto back focus / Manual
<b>Lens</b>	Focal length	2.8 - 10 mm (1/8 inches - 13/32 inches)
	Zoom ratio	3.6 x (Motorized zoom / Auto Focus)
	Angular Field of View	[16 : 9 mode] Horizontal : 30° (TELE) – 110° (WIDE) Vertical : 17° (TELE) – 59° (WIDE) [4 : 3 mode] Horizontal : 25° (TELE) – 90° (WIDE) Vertical : 19° (TELE) – 66° (WIDE)
	Maximum Aperture Ratio	1 : 1.6 (WIDE) – 1 : 3.4 (TELE)
Focusing Range	0.3 m {11-13/16 inches} – ∞	
<b>Adjusting Angle</b>	Horizontal : -240 to +120°, Vertical : ±85°, Yaw : ±100°	
<b>Browser GUI</b>	Camera Control	Brightness, AUX On / Off
	Audio	Mic (Line) Input : On / Off Volume adjustment : Low / Middle / High Audio Output : On / Off Volume adjustment : Low / Middle / High
	GUI / Setup Menu Language	English, Italian, French, German, Spanish, Portuguese, Russian, Chinese, Japanese
<b>Network</b>	Network IF	10Base-T / 100Base-TX, RJ45 connector
	Resolution	<b>*2 mega pixel [16 : 9] (30/60 fps)</b> 1,920 x 1,080 / 1,280 x 720 / 640 x 360 / 320 x 180
	H.265 / H.264 / JPEG (MJPEG)	<b>*3 mega pixel [4 : 3] (30 fps)</b> 2,048 x 1,536 <sup>*5</sup> / 1,280 x 960 / 800 x 600 / 640 x 480 / 400 x 300 / 320 x 240
	H.265 / H.264 <sup>*6</sup>	Transmission Mode Constant bit rate / VBR / Frame rate / Best effort
	JPEG	Transmission Type Unicast / Multicast
	Smart Coding	Image Quality 10 steps
	Smart Coding	Smart Facial Coding <sup>*3</sup> : On (Smart Facial Coding) / On (Auto VQOS) / Off *Smart Facial Coding is only available with Stream(1). GOP (Group of pictures) : On (Advanced) / On (Mid) / On (Low) / Off *On(Advanced) is only available with H.265.

<b>Network</b>	Audio Compression	G.726 (ADPCM) : 16 kbps / 32 kbps G.711 : 64 kbps AAC-LC <sup>*7</sup> : 64 kbps / 96 kbps / 128 kbps
	Audio transmission mode	Off / Mic (Line) input / Audio output / Interactive (Half duplex) / Interactive (Full duplex)
<b>Network</b>	Supported Protocol	IPv6 : TCP/IP, UDP/IP, HTTP, HTTPS, SSL/TLS, RTP, FTP, SMTP, DNS, NTP, SNMP, DHCPv6, MLD, ICMP, ARP, IEEE 802.1X, DiffServ, SRTP <sup>*9</sup> , MQTT <sup>*9</sup> , LLDP <sup>*9</sup> IPv4 : TCP/IP, UDP/IP, HTTP, HTTPS, SSL/TLS, RTSP, RTP, RTSP/RTCP, FTP, SMTP, DHCP, DNS, DDNS, NTP, SNMP, UPnP, IGMP, ICMP, ARP, IEEE 802.1X, DiffServ, SRTP <sup>*9</sup> , MQTT <sup>*9</sup> , LLDP <sup>*9</sup>
	No. of Simultaneous Users	Up to 14 users (Depends on network conditions)
<b>Network</b>	SDXC/SDHC/SD Memory Card	H.265 / H.264 recording : Manual REC / Alarm REC (Pre/Post) / Schedule REC / Backup upon network failure JPEG recording : Manual REC / Alarm REC (Pre/Post) / Backup upon network failure Compatible SDXC/SDHC/SD Memory Card : Panasonic 2 GB, 4 GB*, 8 GB*, 16 GB*, 32 GB*, 64 GB**, 128 GB**, 256 GB** model *SDHC card, ** SDXC card (except miniSD card and microSD card)
	Mobile Terminal Compatibility	iPad, iPhone, Android™ terminals
<b>Alarm</b>	ONVIF <sup>*8</sup> Profile	G / S / T
	Alarm Source	3 terminals input, VMD alarm <sup>*8</sup> , Command alarm, Audio detection alarm
<b>Alarm</b>	Alarm Actions	SDXC/SDHC/SD memory recording, E-mail notification, HTTP alarm notification Indication on browser, FTP image transfer, Panasonic alarm protocol output
	Input/Output	Monitor Output (for adjustment) VBS : 1.0 V [p-p] / 75 Ω, composite, ø3.5 mm mini jack An NTSC or PAL signal can be outputted from camera Audio input ø3.5 mm stereo mini jack Input impedance: Approx. 2 kΩ (unbalanced) (Applicable microphone : Plug-in power type) Supply voltage : 2.5 V ±0.5 V Audio Output ø3.5 mm stereo mini jack (monaural output) Output impedance : Approx. 600 Ω (unbalanced)
<b>General</b>	External I/O Terminals	ALARM IN 1 (Black & white input, Auto time adjustment input) (x1), ALARM IN 2 (ALARM OUT) (x1), ALARM IN 3 (AUX OUT) (x1)
	Safety	UL (UL60950-1), c-UL (CSA C22.2 No.60950-1), CE, IEC60950-1
<b>General</b>	EMC	FCC (Part15 ClassA), ICES003 ClassA, EN55032 ClassB, EN55024
	Power Source and Power Consumption	DC power supply : DC12 V 460 mA, Approx. 5.6 W PoE (IEEE802.3af compliant) Device : DC48 V 125 mA, Approx. 6.0 W (Class 0 device)
<b>General</b>	Ambient Operating Temperature	-10 °C to +50 °C (14 °F to 122 °F)
	Ambient Operating Humidity	10 to 90 % (no condensation)
<b>General</b>	Dimensions	ø129.5 mm x 101 mm (H) (ø5-3/32 inches x 3-31/32 inches (H)) Dome radius 40 mm {1-9/16 inches}
	Mass (approx.)	Approx. 560 g (1.23 lbs)
<b>General</b>	Finish	Main body : ABS resin, sail white / Dome section : Acrylic resin, Clear

- \*1 Converted value
- \*2 Super Dynamic function is automatically set off on 60 fps mode.
- \*3 Stabilizer, Smart Facial Coding, i-VMD can not be used at the same time.
- \*4 When "3 mega pixel [4 : 3](30fps mode)" is selected for "Image capture mode", "90 °" and "270 °" cannot be selected.
- \*5 Used by super resolution techniques
- \*6 Transmission for 4 streams can be individually set.
- \*7 When recording audio on an SD memory card, only use AAC-LC (Advanced Audio Coding - Low Complexity).
- \*8 Including alarms from Plug-in Software
- \*9 It may be necessary to upgrade the firmware to use these protocols.

# Appearance

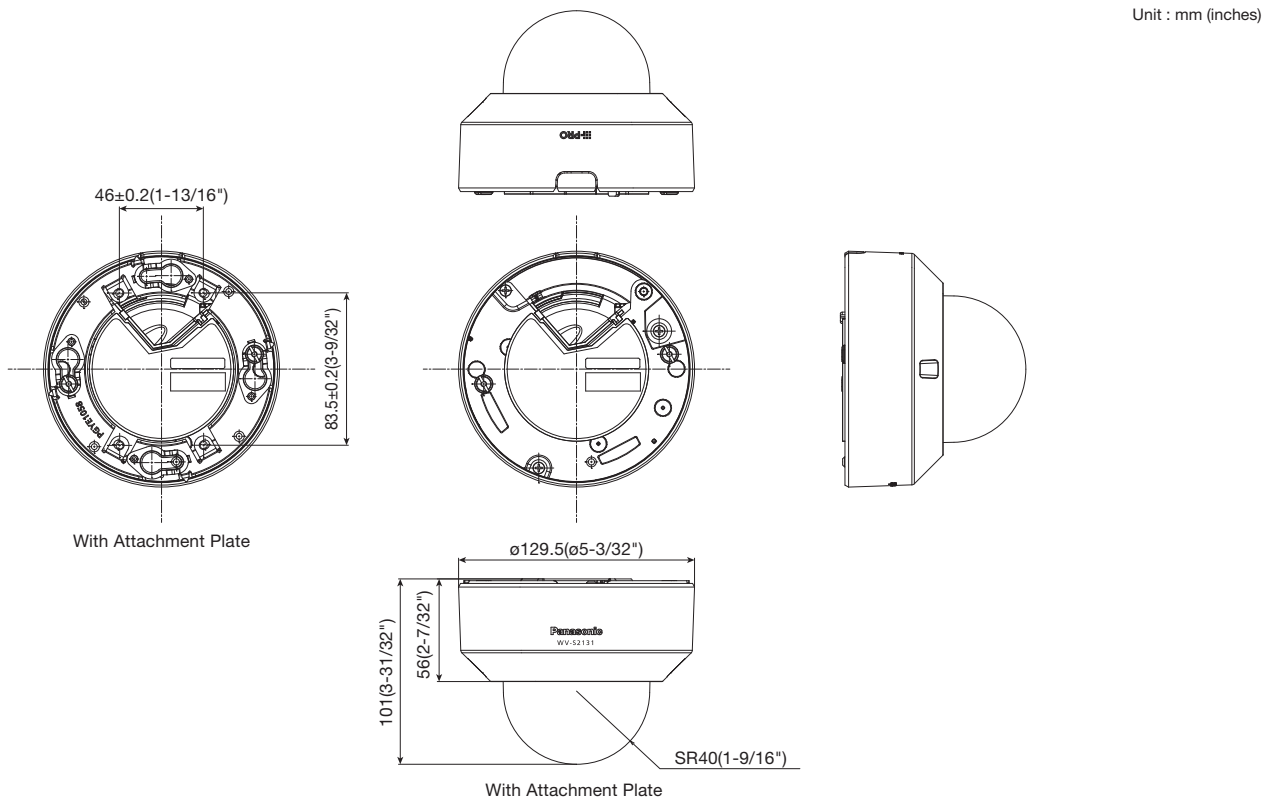

## Bundled License

### Plug-in Software for i-VMD

i-VMD is possible to detect objects in the specified area by advanced video analysis technology.  
 i-VMD : Intruder Detection, Loitering Detection, Direction Detection, Scene Change Detection, Object Detection, Cross Line Detection



Notification sent to the monitoring screen

## Optional Accessories

### Mount Bracket / Dome Cover / Other

<p>Ceiling Mount Bracket <b>WV-Q105A</b></p> 	<p>Ceiling Mount Bracket (Embedded) <b>WV-Q174B</b></p> 	<p>Ceiling Mount Bracket <b>WV-QCL100-W</b> (i-PRO white)</p> 	<p>Mount Bracket <b>WV-QSR501-W</b> (i-PRO white)</p>  (This bracket requires WV-QCL501-W, WV-QWL501-W or WV-QAT500-W.)	<p>Ceiling Mount Bracket <b>WV-QCL501-W</b> (i-PRO white)</p>  (This bracket requires WV-QSR501-W.)	<p>Wall Mount Bracket <b>WV-QWL501-W</b> (i-PRO white)</p>  (This bracket requires WV-QSR501-W.)
<p>Wall Mount Bracket <b>WV-QWL500-W</b> (i-PRO white)</p> 	<p>Adapter Box <b>WV-QJB500-W</b> (i-PRO white)</p>  (This bracket requires WV-QWL500-W.)	<p>Pole Mount Bracket <b>WV-QPL500-W</b> (i-PRO white)</p>  (This bracket requires WV-QWL501-W.)	<p>Corner Mount Bracket <b>WV-QCN500-W</b> (i-PRO white)</p>  (This bracket requires WV-QWL501-W.)	<p>Attachment pipe (For 3rd party bracket) <b>WV-QAT500-W</b> (i-PRO white)</p>  (This bracket requires WV-QSR501-W.)	<p>Dome Cover (Smoke Type) <b>WV-CF5SA</b></p> 

• Brackets are available in four colors, Fine silver, Light gray, Gray and i-PRO white. It is possible to use them in different color combinations.

#### Trademarks and registered trademarks

- iPad and iPhone are trademarks of Apple Inc., registered in the U.S. and other countries.
- Android is a trademark of Google LLC.
- ONVIF is trademarks or registered trademarks of Onvif Inc.
- All other trademarks identified herein are the property of their respective owners.

#### Important

- Safety Precaution : Carefully read the Basic Information, Installation Guide and Operating Instructions before using this product.
- Panasonic cannot be responsible for the performance of the network and/or other manufacturers' products used on the network.

• Masses and dimensions are approximate. • Specifications are subject to change without notice.

# Panasonic®

Panasonic Corporation

Panasonic i-PRO Sensing Solutions Co., Ltd.

<https://i-pro.com/corp/>

<https://i-pro.com/global/en/surveillance>

<https://www.linkedin.com/company/i-pro-sensing-solutions-co-ltd/>