



Security Radar Guide

WV-RD5500-CE/WV-RD5500-CSE

Contents

1	Introduction	1
	1.1 About the Security Radar Guide for Monitoring	1
	1.2 Supported models and symbols of this manual	1
	1.3 Abbreviations	2
	1.4 Disclaimer	2
	1.5 Trademarks and registered trademarks	3
	1.6 Notes on Networking	3
	1.7 Notes on Use	4
2	Introduction	7
	2.1 About calibration	7
3	Operation	10
	3.1 Initial Settings	10
	3.2 Viewing Images from a PC	15
	3.2.1 Viewing Security Radar images	15
	3.2.2 About Live image pages	19
	3.3 About Live image pages in Security Radar	20
	3.4 Operation when an alarm occurs	24
	3.4.1 Alarm type	25
	3.4.2 Operation when an alarm occurs	25
	3.5 Playing back images stored on a SD memory card	26
	3.5.1 Playing back images stored on a SD memory card	27
4	Setting	31
	4.1 Opening the Settings pane from the PC	31
	4.1.1 How to display	31
	4.1.2 How to operate	31
	4.1.3 About the settings panel screen	32
	4.2 Setting Radar [Radar]	34

4.3	Configuring settings related to installation angle errors [Installation angle error detection]	35
4.4	Setting Alarm [Alarm]	35
5	Displaying the Advanced Settings menu of the Security Radar from the PC	38
<hr/>		
5.1	How to display	38
5.2	How to operate	39
5.3	Camera Settings Menu Screen	41
6	Advanced settings	43
<hr/>		
6.1	To set event operation [Event Operation]	43
6.1.1	Setting Schedule/Alarm (Event Type Setting Screen)	47
6.1.2	Alarm: Setting the terminal and operation detection (Alarm setting screen)	47
6.1.3	Alarm: Set operating conditions (Alarm type setting screen)	51
6.1.4	Alarm: Set detailed image transfer and recording conditions	52
6.1.5	Alarm: Setting output terminals	55
6.1.6	Alarms: Set up email notifications and mail servers	55
6.1.7	SCHEDULE: Set SD Recording (Video Recording Setting Window)	57
7	Advanced Settings Perform basic settings for this machine [Basic]	63
<hr/>		
7.1	Perform basic settings [Basic]	63
7.2	Setting an SD Memory Card [SD Memory Card]	67
7.2.1	Detection of tampering	75
7.3	Setting an overlay image [Overlay image]	78
8	Configuring Advanced Image and Audio Settings [Video/Audio]	82
<hr/>		
8.1	Setting the imaging mode [Video]	82
8.2	Setting JPEG images [Video]	82
8.3	Configuring Stream Settings [Video]	84
8.4	Setting the image quality [Quality]	91
8.4.1	Adjusting Image Quality (Quality Adjustment Screen)	93
8.4.2	Set the mask area	102
8.4.3	Adjust the digital zoom	104

8.4.4	Configuring Privacy Zone Settings (Privacy Zone Settings Screen)	105
8.4.5	Set the VIQS	107
8.4.6	Setting the lens distortion correction	109
8.4.7	Setting Angle Error Detection	109
8.5	Setting sound [Audio]	110
9	[Radar] to set advanced radar settings	114

9.1	[Radar Settings] for setting units	114
9.2	[Radar Settings] for configuring basic radar settings	114
9.3	[Radar Settings] for configuring radar-related settings	116
9.4	[PTZ Linkage] for checking the connectivity of registered PTZ	117
9.5	Setting Up PTZ Camera-Tracking [PTZ Linkage]	117
9.6	[Radar detection] for setting radar detection	118
9.6.1	Radar detection setting [Radar detection settings screen]	118
9.6.2	Advanced [Radar detection settings screen]	123
9.6.3	Link to alarm setting [Radar detection settings screen]	125
9.7	[Radar Settings] for setting radar disturbance detection	127
10	Advanced Alarm Settings [Alarm]	128

10.1	[Alarm] for setting alarm operations	128
10.2	[Alarm] for setting pins	131
10.3	[Alarm] whose AUX name is to be changed	133
10.4	[Alarm] for setting interlocked alarm operation	134
10.4.1	Set Email Sending When an Alarm Occurs	135
10.4.2	Settings related to SD memory card recording when an alarm occurs	135
10.4.3	Settings related to TCP alarm notification notification when an alarm occurs	135
10.4.4	Settings related to HTTP alarm notification when an alarm occurs	135
10.4.5	Setting for SNMP Send When an Alarm Occurs	136
10.5	[VMD area] to set operation detection	136
10.6	[VMD area] to set operation detection area	139
10.7	[SCD area] for configuring disturbance detection	141
10.8	[SCD area] to set the disturbance detection area	144
10.9	[Audio detection] for configuring sound detection settings	147
10.10	To set impact detection [Impact Detection]	148

10.11	[Transmission] for setting the alarm notification	150
10.11.1	Setting Up TCP alarm notification Notifications	150
10.11.2	Setting HTTP Alarm Notification	152
11	Advanced Networking Settings [Network]	154
<hr/>		
11.1	[Network] to set up networking	154
11.2	[Advanced] for advanced networking settings	158
11.2.1	Setting Mail Sending	159
11.2.2	Set the SNMP	163
11.2.3	Set the MQTT	169
12	[Schedule] to set advanced scheduling	172
<hr/>		
12.1	How to set the schedule	176
12.2	How to delete a schedule	179
12.3	How to set the image quality to be changed by the sunrise time and sunset time	181
13	Other	183
<hr/>		
13.1	System log display	183
13.2	Troubleshooting	184
13.3	SD Memory Card Directory Structure	192
13.3.1	About Security Radar Directory–Configuration	192
Calibration guide		193
<hr/>		
1.	Overall flow	193
2.	Simulation with System Design Tool	195
2.1	Launch the system design tool	195
2.2	Adding Security Radar to Representative Models	196
2.3	Loading Map Data into System Design Tools	199
2.4	Placing the Security Radar on the Map	201
2.5	Entering Installation Information and Checking the Detection Range	204
2.6	PTZ Positioning the Camera on the Map	205
2.7	Exporting Project Files	206
2.8	Pre–Simulation of Radio Interference Avoidance with i–PRO Configuration Tool	208

2.9 Preparing for Security Radar Calibration Configuration with i-PRO Configuration Tool	209
3. Preparing for i-PRO Configuration Tool	213
3.1 Getting and Installing the i-PRO Configuration Tool	213
3.2 Verifying Hardware Environment Connectivity	214
3.3 Starting the i-PRO Configuration Tool	214
4. Radio interference avoidance	220
4.1 Procedures for radio interference avoidance	220
5. Security Radar calibration settings	225
5.1 To start the calibration screen	225
5.2 Select the configuration pattern	227
5.3 Initial Security Radar Settings	229
5.4 System design tool link	230
5.5 PTZ Cameras Linking	233
5.6 Calibrating the Security Radar	235
5.7 PTZ Camera Calibration	254
5.8 Setting latitude and longitude information	260
5.9 Alarm notification setting	261
5.10 Radar Settings (Security Radar)	266

1 Introduction

1.1 About the Security Radar Guide for Monitoring

This manual explains how to operate the machine software. It also explains how to calibrate the machine using the i-PRO Setup Tool (iCT).

For monitoring using a web browser in this document Millimeter wave radar This chapter explains operations and settings, but we recommend using the i-PRO Setup Tool (iCT) for various settings. I-PRO Setup Utility (iCT) on our Technical Info website <Control No. :C0133> See also.



[Note:]

• [used] in this document [<Control number: Cxxxx>] is the number used to search for the relevant information in our technical information website.

https://i-pro.com/products_and_solutions/en/surveillance/learning-and-support/knowledge-base/technical-information

- Screen photographs are used according to the guidelines of Microsoft Corporation.
- This document describes the operation when using the Japanese version of Google Chrome as a representative. For confirmation of the operation of the corresponding Web browser, please refer to our Technical Information Web site <Control No.: C0132>.

1.2 Supported models and symbols of this manual

The supported models in this manual are listed in the model column of the table below.

Functions restricted by model in this manual indicate models that can be used with the following symbols and terminology. All models are compatible with functions for which this symbol is not used.

Symbol	Term	Model
[Security Radar radar]	Millimeter-wave radar for monitoring	WV-RD5500-CE/ WV-RD5500-CSE



[Notice]

- The camera part of the equipment is described as "Camera", and the radar part is described as "Radar".

1.3 Abbreviations

The following abbreviations are used in this document:

MicroSDXC/microSDHC/microSD memory cards are referred to as SD cards or SD memory cards.

The Universal Plug and Play is referred to as UPnP™ or UPnP.

1.4 Disclaimer

- This product is designed to obtain images for monitoring specific areas. This product does not prevent crimes by itself.
- In no event shall we be liable for.
 1. Any incidental, special, or consequential damages or damages directly or indirectly arising in connection with the product
 2. Any and all failures or malfunctions caused by any disassembly, repair or modification of the product by the customer, whether or not caused by such disassembly or modification
 3. Any inconvenience, damage, or damage caused by the inability to display images due to any reason or reason, including product failure or malfunction
 4. Failure, inconvenience, damage, or damage caused by a system combined with a third-party device
 5. Compensation claims, claims, etc. arising from the use of monitored images or records made public by the customer for any reason (including use in a user-authenticated OFF) or the infringement of privacy by the subject person or entity
 6. The registered data is lost due to some reason (including when the product is initialized by forgetting the credentials such as repair, username, and password).

1.5 Trademarks and registered trademarks

- **Trademarks and registered trademarks**
 - Microsoft, Windows, Windows Media, Internet Explorer, Microsoft Edge and ActiveX are either registered trademarks or trademarks of Microsoft Corporation in the United States and/or other countries.
 - Intel, Intel Core is a trademark of Intel Corporation or its affiliates in the United States and/or other countries.
 - Android and Google Chrome are trademarks of Google LLC.
 - Firefox is a trademark of Mozilla Foundation in the United States and elsewhere.
 - Other company and product names described in this manual are trademarks or registered trademarks of their respective companies.

1.6 Notes on Networking

Since this machine is connected to the network, the following damage may occur.

1. Leaks and leaks of information through the machine
2. Unauthorized operation of this equipment by a malicious third party
3. Malicious Third Party Interference or Stop the Instrument

To prevent such damage, take thorough network security measures, including the following measures, under the customer's responsibility.

- Use this machine on a secure network using a firewall or the like.
- When using this machine in a system to which a PC is connected, make sure that computer viruses and malicious programs are regularly checked for infection and disinfected.
- To protect against unauthorized attacks, use user authentication, set user names and passwords, and restrict users who can log in.
- To prevent image data, authentication information (username, password), alarm e-mail information, FTP server information, and DDNS server information from being leaked over the network, measures such as restricting access with user authentication are implemented.
- Be sure to close all browsers after the administrator has accessed this machine.
- Change the administrator password periodically. In addition, the authentication information (user name and password) shall be stored appropriately so as not to be accessed by third parties.

- Do not install the server in a location where it can be easily destroyed.

1.7 Notes on Use

When using this unit via the Internet

To prevent unintentional access by third parties,
Keep the user-authentication setting set to [On].

To ensure long-term stable operation

Avoid prolonged use in hot or humid places. Deterioration of the parts shortens the service life.
Improve the heat radiation at the installation site and make sure that the product is not exposed to direct heat.

Repeated power OFF/ON can lead to malfunction.

Handle with care

Do not drop the product or subject it to strong impact or vibration. Doing so may cause a malfunction.

Do not touch the dome cover directly

Dirt may deteriorate image quality.

Automatically restarts when an error is detected.

If an error is detected for any reason, the server automatically restarts. When the system is restarted, as when the power is turned onAbout 2 minutesThe operation cannot be performed.

Function for Detecting Operating Status

If abnormal operation is continued for more than 30 seconds during use due to the influence of external noise, etc., this unit automatically restarts and recovers from normal operation. Restart performs the same initial operation as when the power is turned on. However, if this occurs frequently, there may be a lot of external noise in the installation environment of this unit.

Contact your dealer as soon as possible to prevent malfunction.

When a periodic screen skew occurs

If this unit is installed in a location that vibrates slightly (for example, near a vibrating device), the screen may expand and contract periodically, causing distortion.

This is a special phenomenon that occurs when a CMOS sensor is used as the image pickup device and is caused by the periodic movement of the screen and the image readout timing. This is not a malfunction of this unit. Re-check the installation conditions and ensure the stability of the machine to reduce this phenomenon.

We shall not be liable for any compensation for failure to properly record or edit images or loss of

recorded or edited data due to a failure of this unit and the microSD memory card. Also, we shall not be liable for any direct or indirect damages caused thereby. The same shall apply when the machine is repaired.

About CMOS sensors

- If there is a bright area such as spotlight in a part of the picture, the color filter inside the CMOS sensor may deteriorate and the area may be discolored.
- When a fast-moving object is displayed, objects across the screen may bend at an angle.

Maintenance

Turn off the power before performing this procedure. Doing so may cause injury.

Do not sprinkle or use benign, thinner, or any other organics. The case may become discolored.

When using a chemical cloth, follow the precautionary statements.

Do not loosen or remove screws not instructed in the instruction manual.

Cleaning the Dome Cover

If the dome cover is dirty, clean it with a lens cleaning paper (for cleaning the camera and glasses).

When the equipment is transferred or disposed of

The contents of information recorded on this machine and the contents of information recorded on the storage medium used with this machine may correspond to "personal information". If this equipment is disposed of, transferred, repaired or otherwise handed over to a third party, it must be handled with care. When discarding a storage medium, it is recommended to physically destroy it after deleting it with a PC.

In addition, delete the device or user information registered in the external service or application that uses this machine.

Connecting to the Internet

This handset cannot connect directly to telecommunications lines (including public radio LAN) of telecommunications carriers (mobile communications companies, fixed-line telecommunications companies, Internet providers, etc.). When connecting this unit to the Internet, be sure to connect it via a router or other device.

Protection of personal information

Information that can be distinguished by a person shot by a system using this machine corresponds to "Personal Information" defined in the "Act on the Protection of Personal Information"* Handle video information properly in accordance with laws.

*Please refer to [Cases that Apply to Personal Information] in the "Guidelines for the Protection of Personal Information (General Rules)" of the Personal Information Protection Committee.

About Routers

When using a router to connect this unit to the Internet, use a broadband router with a port

forwarding function (NAT, IP masquerading). For an overview of the port forwarding function, refer to the user manual.

About Time Setting

The time must be set before operation of this machine starts. For information on setting the time, see the user manual.

2 Introduction

The basic settings include camera titles, date and time settings, SD memory cards, and overlays. The basic page consists of the [Basic] tab, [SD memory card] tab, and [Overlay Image] tab.

2.1 About calibration

Calibration is a setting that matches the physical location of linked devices (Security Radar or PTZ).

It is recommended to perform calibration using the following tools in the flow.

[Security Radar Radar Calibration Workflow](#)

The following calibration steps are required when initializing the Security Radar.

Refer to the calibration guide for details. → [Calibration guide](#)

If calibration has already been completed, (1) to (10) are not required.

(11), For details of (12), refer to Chapter 3 "OPERATION" and thereafter. → [3 Operation](#)

Calibration procedure

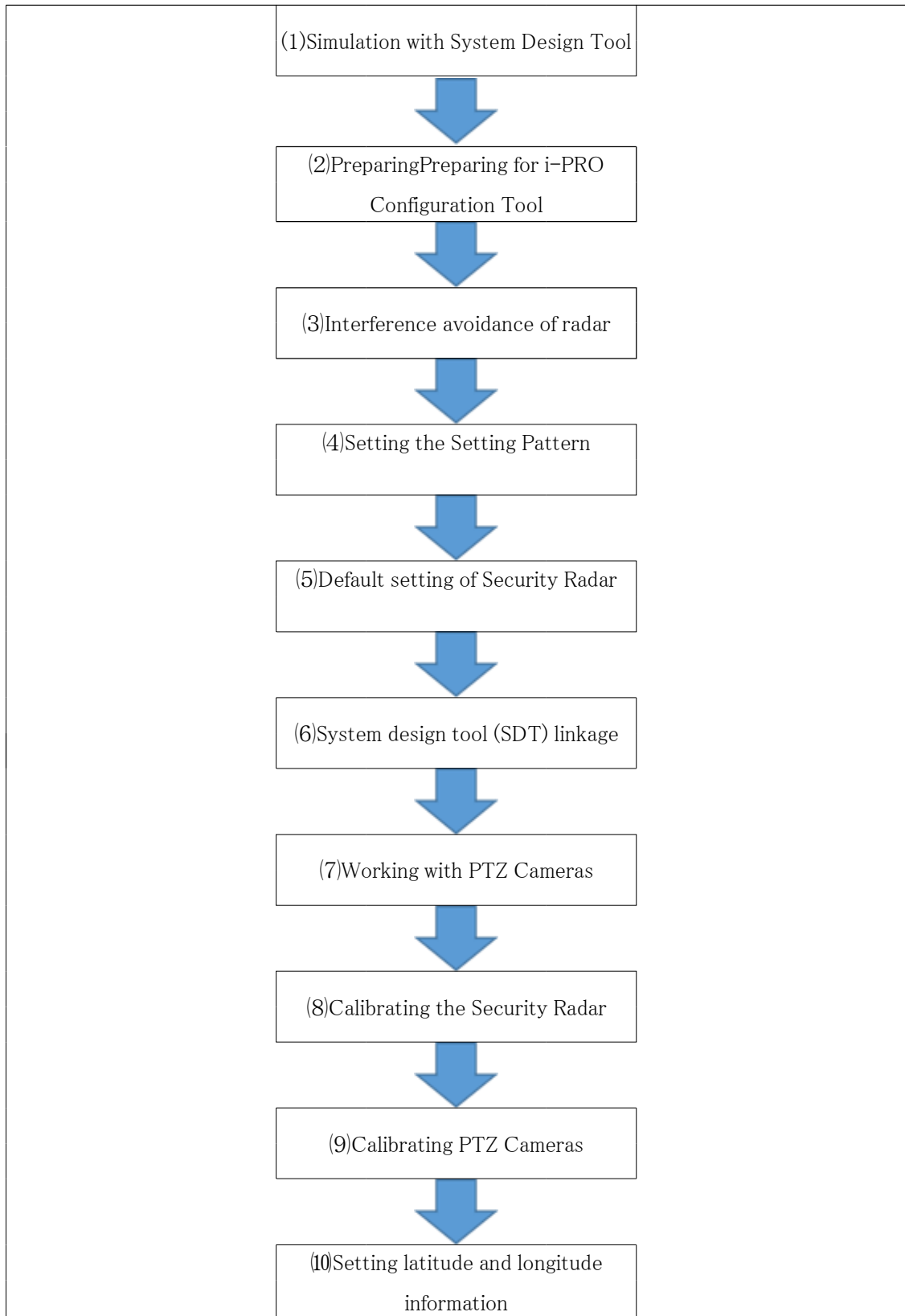

Calibration procedure (*continued*)

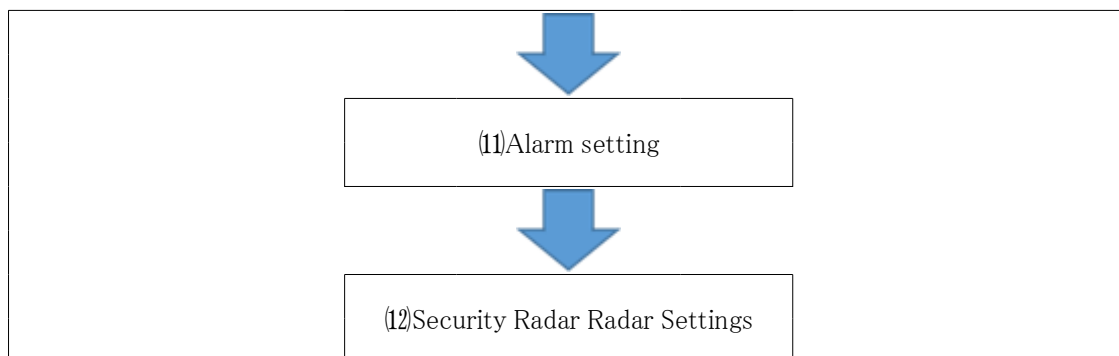

3 Operation

3.1 Initial Settings

[Registering an administrator](#)

The administrator registration screen is displayed when the camera is accessed for the first time (also displayed when the machine is initialized).

Specify the user name and password of the administrator, and enter them to make sure that they are correct. Used for subsequent logins.

Administrator registration

The initial setup of the administrator name and password is required on this screen.
Manage them safely and be sure not to forget them.

User name (1 to 32 characters)

Password (8 to 32 characters)

Retype password

Note:

- (1) Distinguish between upper- and lower cases.
- (2) Entry of the following is not allowed as a user name: 2-byte characters, and 1-byte symbols " & ; \
- (3) Entry of the following is not allowed as a password: 2-byte characters, and 1-byte symbols " &
- (4) For the password, use three or more types of characters from upper- and lowercase alphabetic characters, numbers, and symbols.
- (5) Keep the user name and password at hand so as not to lose.
- (6) It is recommended to change the password periodically.
- (7) Set the password which does not include the user name.

• [User name (1 to 32 characters)]

Enter the administrator user name.

- **Number of characters that can be entered:** 1 to 32 characters
- **Characters that cannot be entered:** Two-byte or one-byte symbol " & ; ¥



[Notice]

• The display of "¥" which cannot be entered may differ depending on the model.

• [Password (8 to 32 characters)]/[Retype password]

Enter the administrator's password.

- **Number of characters that can be entered:** 8 to 32 characters
- **Characters that cannot be entered:** Two-byte or one-byte symbol "&



[Notice]

- Please enter it in upper case and lower case.
- Use at least three types of passwords: uppercase letters, lowercase letters, numbers, and symbols.
- Make sure that the password does not contain a user name.



[Important]

- If you do not know the specified user name and password, you need to initialize the camera. When the camera is formatted, all settings are erased. Keep the user name and password in a safe place so that others can't see them. For the initialization method, See WEB guidance Please.
- Do not use other cameras, devices, or other passwords.

After registering the administrator's user name and password, the language/date/time setting screen is displayed.

[Language/Date/Time Settings](#)

Language/time and date setting

Menu language	Date/time display	Time display format	Date/time display format
English ▾	On ▾	24h ▾	Mmm-DD-YYYY ▾
Date	Time	Date/time position	
Nov-27-2025 📅	16:52:47 🕒	Upper left ▾	

Set PC time to the camera

Time zone

(GMT+09:00) Osaka, Sapporo, Tokyo ▾

Summer time(daylight saving)

Out ▾

Screen setting

Color	Operation panel layout
Light ▾	Bottom ▾

Set

Language/Date/Time Settings

- **[Menu language]**

Choose the first language that appears when you access the camera:

[Auto]/[English]/[Japanese]/[Italian]/[French]/[German]/[Spanish]/[Chinese]/[Russian]/[Portuguese]

[Auto]: The language used in the browser is automatically selected. If your ASUS Phone does not support the language, English is selected.

- **[Time display format]**

Select how the time is displayed from the 24h/12h.

- **[Date/time display format]**

Select the date display format. When [Date] is set to [April 1, 2021 at 13:10:00 seconds], the display formats are as follows.

- DD/MM/YYYY: 01/04/2021 13:10:00

- MM/DD/YYYY: 04/01/2021 13:10:00
- DD/Mmm/YYYY: 01/Apr/2021 13:10:00
- YYYY/MM/DD: 2021/04/01 13:10:00
- Mmm/DD/YYYY: Apr/01/2021 13:10:00
- **[Date]**
 - ☐ Click the button to set the camera date.
 - ☐ When clicked, the PC date is obtained and displayed.
- **[Time]**
 - Click the button to enter the camera time.
 - When clicked, the PC time is acquired and displayed.



[Important]

- If more accurate time settings are required for system operation, use a NTP server. Refer to the user manual for details.

- **[Date/time position]**

Select the position to display the date and time on the image.

 - [Upper left] : Displays at the top left of the window.
 - [Lower left] : Appears at the bottom left of the window.
 - [Upper center]: Appears at the top center of the display.
 - [Lower center]: Appears at the bottom center of the window.
 - [Upper right]: Appears in the upper-right corner of the window.
 - [Lower right] : Appears in the lower right corner of the window.



[Notice]

- To set whether to display the date and time on the picture, use [Basic] of the Advanced Menu.

→7 [Advanced Settings Perform basic settings for this machine \[Basic\]](#)

- **[Time zone]**

Select the time zone that suits the region of the camera you are using.
- **[Summer time(daylight saving)]**

Set whether to use daylight saving time by [In]/[Out]/[Auto]. Set the time zone where daylight saving time is used.

 - [In] : Sets the time to daylight saving time. [*] is displayed on the time display.
 - [Out] : Daylight saving time is deactivated.
 - [Auto] : Switches to Daylight Saving Time according to the start date and time and the end

date and time setting (month, week, day of the week, and time).

- **[Start time & date] [End time & date]**

When [Auto] is selected in the [Summer time(daylight saving)] setting, set the start and end dates and times of daylight saving time by month, week, day of the week, and time.

Display Settings

- **[Color]**

Selects the [Light] or [Dark] as the background color for the Control Panel/Advanced Settings menus.

- **[Operation panel layout]**

Select the location of the operator panel from [Right], [Left], and [Bottom].

3.2 Viewing Images from a PC

This section describes how to view Security Radar images from the PC.

3.2.1 Viewing Security Radar images

- 1 Launch your PC web browser.
- 2 Enter the IP address that you configured in the IP Quick Setup software into the [Address] Box of your web browser.

Sample IPv4 addressing entry:URL registered by http://IPv4 address

http://192.168.0.10/

Sample IPv6 addressing entry:URL stored in http://[IPv6]

http://[2001:db8::10]/

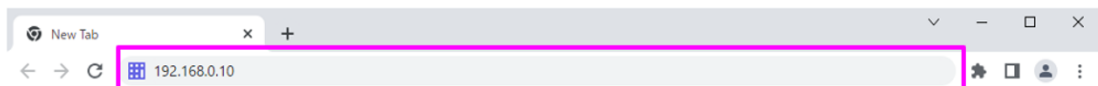

[Important]

- If the HTTP port number has been changed from [80], enter [http:// Camera IP Address: Port Number] in the [Address] Box.

Example: If the port number is set to 8080: http://192.168.0.11:8080

- If this machine is in the local network, configure the proxy server settings

([Set]-[Network and Internet]-[Proxy]) so that the proxy server is not used for the local address.

- When accessed via IPv6, streamed video cannot be displayed on the live image screen. If you want to view the streamed video in the live image window, please visit the IPv4.





[Notice]

- Due to browser limitations, there is a limit to the number of browsers that can display video at the same time. If you attempt to display images in multiple browsers, the images may not be displayed.
- If you have configured [HTTPS] in [HTTPS]-[Connection] on the [Advanced] tab of the Network page, see the video in the support video page of our technical information website. <Control No. :P0002><Control No. :P0003>See also.
→ [11 Advanced Networking Settings \[Network\]](#)

- 3 [Enter] Press the key to display the screen for entering the user name and password.

Language/time and date setting

Menu language	Date/time display	Time display format	Date/time display format
English ▾	On ▾	24h ▾	Mmm-DD-YYYY ▾

Date	Time	Date/time position
Nov-27-2025 	16:52:47 	Upper left ▾

Set PC time to the camera

Time zone

(GMT+09:00) Osaka, Sapporo, Tokyo ▾

Summer time(daylight saving)

Out ▾

Screen setting

Color	Operation panel layout
Light ▾	Bottom ▾

Sign in

http://192.168.0.10
Your connection to this site is not private

Username

Password



[Notice]

- If [User auth.] is set to [Off], the username/password entry window is not displayed prior to the Live image pages is displayed.

- 4 Enter your username and password. Clicking [Login] displays the Live image pages. For more information about Live image pages, see the following:

→[3.2.2 About Live image pages](#)



[Important]

- Depending on the performance of the PC, an image may not be displayed if you attempt to view more than one H.265 (or H.264) image on one PC.



[Notice]

- The maximum number of users that can access the machine simultaneously is [Max. Users], which is the sum of the users receiving H.265 (or H.264) images and the users receiving JPEG images. However, depending on the setting of [Bandwidth control(bit rate)] [Bit rate per client*], the number of users that can be accessed may be limited to [Max. users]. If the maximum number of users that can be accessed is exceeded, the access exceeded message is displayed. When [Stream numbers]'s [Transmission type] is set to [Multicast], the second and subsequent users receiving H.265 (or H.264) images are not counted as accessed.
- [Maximum number of users] is 14.

- When [Stream transmission] is set to [On], the H.265 (or H.264) images are displayed according to the [Compression] setting. When set to [Off], displays JPEG images. Even if [Stream transmission] is set to [On], you can still view JPEG images. However, the image-refresh rate of JPEG images is limited as shown in the following tables

→[8.3 Configuring Stream Settings \[Video\]](#)

- The image-updating speed of JPEG images may be slower depending on the network-environment, PC performance, object, and number-of-accesses.

Security Radar

Please read the following for the relation between the model and the symbols and terminology.

→[1.3 Abbreviations](#)

Security Radar : Radar Side

Image capture mode	Image capture size	Streaming	
		On	Off
		JPEG	JPEG
16:9 mode (30fps mode)	1920x1080	Max. 5fps	Max. 5fps
16:9 mode (25fps mode)	1280x720		
	640x360		
	320x180		

Security Radar : Camera-side

Image capture mode	Image capture size	Streaming	
		On	Off
		JPEG	JPEG
16:9 mode (30fps mode)	1920x1080	Max. 5fps/4.2fps	Max. 30fps/25fps
16:9 mode (25fps mode)	1280x720		
	640x360		
	320x180		

3.2.2 About Live image pages



[Notice]

- The buttons and setting items displayed on the Live image pages can be changed according to the user privileges of the accessing user. User privileges are set in the [User auth.] of the [User mng.]. For more information, see the user manual.
- The design and layout of the screen may change.

3.3 About Live image pages in Security Radar



1. **[Camera Title]**
 [Camera] on the [Basic] tabbed page titleCamera entered in]TitleIs displayed.
 Click the icon and the camera.TitleThe text becomes Box and the text can be edited.
2. **[SD save status]**
 Displays the status of saving data to the SD memory card.
 When saving starts, the SD save status indicator turns red. When saving stops, it turns off.
 This message appears when [Save trigger] in the Setting menu is set to [Manual save] or [Schedule].
 →7.2 [Setting an SD Memory Card \[SD Memory Card\]](#)
3. **[Display image]**
 You can switch between the radar screen and the camera screen.
4. **[Stream information display]**
 Displays the video compression, Image capture size, and frame rate.
5. **[Snap shot] button**
 A snapshot (one still image) is taken and the image is displayed in a separate window. If you right-click on the image, you can save the image using the web browser.



[Notice]

- If the snapshot takes longer than a certain amount of time to take, for example, due to a network environment, the image may not be displayed.
- If the JPEG of the specified Image capture size cannot be obtained, the JPEG

images of the Image capture size that can be obtained are displayed.

Therefore, if you take a JPEG image in a snapshot and browse it in the PC, it may differ from the displayed image size.

6. **[Stream selection display]button**

You can show or hide the popover display on the stream selection screen. In the stream-selection window, you can configure settings such as [Live only].

7. **[Compare before/after images]button**

Click the icon to download and display the still image. You can compare the acquired still image as the image before changing the image quality setting.

1:1: The downloaded still image and the latest image are displayed in the same size.

1:2: The acquired still image and the latest image are displayed side by side so that the latest image is twice the size.

Off: Displays only the latest image.

8. **[Support]button**

Click the Support button to display our technical information website in a separate window. Our technical information website contains technical information, FAQ (frequently asked questions), etc.

9. **Full Screen button**

A new window opens with the image in full screen.

10. **[Grid display] button**

You can switch the grid-display On/Off that can be used to adjust the position of the machine when using Extension software.

For more information about the sizing of each Extension software we sell and provide, see our Technical Info website.<Control No. :C0320>They are listed.

11. **Frame Rate/Bit Rate Display button**

Live image Displays the frame rate and bit rate of the displayed stream.



[Notice]

The button is not displayed when the displayed live image is as follows.

- JPEG streaming view
- Updating JPEG still image

12. **[Change Angle of View] button**

The indicator screen of the angle of view for installation is displayed.

→[4.3 Configuring settings related to installation angle errors \[Installation angle error detection\]](#)

13. **[Camera control panel display] button** ()

You can display or hide the camera control panel. [Brightness] and other settings can be set on the camera control panel.

14. **[Set] button** ()

You can show or hide the settings panel.

→ [4.1.3 About the settings panel screen](#)

15. **[PTZ Manual Tracking]**

Clicking the image on the radar will take a picture of where the linked PTZ cameras clicked. PTZ tracks what you've clicked on the radar-side picture.

**[Notice]**

- For PTZ cameras with auto-tracking On, the linked PTZ cameras may track different objects, depending on where they are shot. This phenomenon may be improved by performing calibration again. Refer to the user manual for details on auto tracking. Refer to the calibration guide for calibration.

→ [Calibration guide](#)

16. **[Main Area]**

Displays the camera image.

The current date and time are displayed according to the [Time display format] and [Date/time display format] settings.

→ [7 Advanced Settings Perform basic settings for this machine \[Basic\]](#)

Also, the set screen characters are displayed. The number of lines displayed is 2.

When displaying in H.265, if the bit-rate is high, it may be displayed in the refresh interval.

17. **[Live only]-[Live only] pull-down menu**

You can select from the following images to display in the main area.

When [Radar]/[Cameras] is selected: [Stream(1)]/[Stream(2)]/[JPEG]

When [Dual] is selected: [Stream(2)]/[JPEG]

The images in the main-area are displayed according to the settings of the streams (1) to (2) and the JPEG.

You can also set the first stream that is displayed when accessing the camera in [Initial display stream] on the [Stream numbers] tab..

→ [8.3 Configuring Stream Settings \[Video\]](#)

18. **[Live only]-[Layout] pull-down menu**

Select the layout of the camera images to be displayed in the main area from [Left/right display] and [Up/down display].

19. **[Live only]-[Camera display order] pull-down menu**

In [Camera display order], select [Radar-Camera] or [Camera-Radar] for the order in which the camera is displayed.



[Notice]

- You can only configure [Layout], and [Camera display order] if you select [Dual] for [Camera to be displayed].

20. **[Stream]-Show streaming info**

Displays the video compression, Image capture size, and frame rate.

21. **[Camera Control Panel]-[Brightness]**

Can be adjusted within 0 to 255. + Clicking the button brightens the image, - Click the button to darken the image. ↻ Click the button to return to the default settings. This item cannot be set when [Dual] or [Radar] is selected in [Display image].

22. **[Camera Control Panel]-[Voice (Listen to PC)]**

This item can be set for the following settings. • When [Audio transmission mode] is set to [Mic input] or [Interactive(Full-duplex)]/[Interactive(Half-duplex)]

- When [Audio input encoding format] is set to [AAC-LC]

- button + By clicking the button or moving the volume cursor, you can adjust the earpiece volume in four levels: [Off]/[Low]/[Medium]/[High].

→8.5 Setting sound [Audio]

23. **[Camera control panel]-[Voice Sent (Speak from PC)]**

This item is configurable only when [Audio transmission mode] is set to [Audio output] or [Interactive(Full-duplex)] [Interactive(Half-duplex)] in the configuration menu.

- button + By clicking the button or moving the volume cursor, you can adjust the volume of the dialogue in four levels: [Off]/[Low]/[Medium]/[High].

→8.5 Setting sound [Audio]



[Notice]

- When [Audio volume control mode] is set to [Adjust Mic input] in the Setting menu, you cannot control the volume cursors when using [Audio] or [Audio detection].

- When you restart the voice recorder, the earpiece volume changed by the volume cursor returns to the earpiece volume set in the [Audio] tab. in the Setting menu.

→8.5 Setting sound [Audio]

- The volume cursor cannot be finely adjusted on the screen. It operates in four

stages.

- If you open more than one camera browser at the same time on the same PC, the audio of the camera browser that was opened later will not be heard. Please access and check one unit at a time.
- If the network communication is unstable, the voice reception may stop. In this case, On/Off the earpiece key to resume the voice reception.

24. **[Camera Control Panel]–[AUX]**

This item is available only when [PIN 3] of the [Alarm] is set to [AUX output] in the ADVANCED SETTING menu.

→6.1.2 [Alarm: Setting the terminal and operation detection \(Alarm setting screen\)](#)

[Open] button: The AUX connectors are now Open.

[Close] button: The AUX terminal enters the Close status.



[Notice]

- You can change the names of the [AUX], [Open], and [Close].

→10.3 [\[Alarm\] whose AUX name is to be changed](#)

25. **[Camera Control Panel]–SD Memory Card–[Log/Play]**

Clicking [Start] displays the log list and allows you to play back the images stored on the SD memory card. For details on the log list and how to play back images, refer to the following.

26. **[Alarm notification]**

When an alarm occurs, a popover is displayed. [X] Click the button to reset the output terminal and clear the display.



[Notice]

- Alarm notification is not linked to alarm notification operations such as recording to a SD memory card or forwarding mail, so please check the respective operation settings.

3.4 Operation when an alarm occurs

When the following alarms occur, the unit performs an alarm operation (camera operation associated with an alarm) according to the setting.

3.4.1 Alarm type

[Terminal alarm]:When an alarm device such as a sensor is connected to the alarm input terminal, the alarm operates when the connected alarm device operates.

[Tamper Detection alarm]:An alarm is activated when it is judged that the radar detection is not working properly, for example, by placing an obstacle in front of the radar eye.

[VMD alarm]:If a change (movement) is detected in the image of the set operation detection area, the alarm operation is performed.

* Operation detection: VMD(Video Motion Detector) = Motion detection, Motion detector function

[Scene change detection (SCD) alarm]:The alarm activates when the object changes by covering the camera with a cloth, lid, etc., or by changing the direction of the camera.

[Command alarm]:When a TCP alarm notification notification is received from the connected device through the network, the alarm operates.

[Audio detection alarm]:When the set sound detection threshold is exceeded, the alarm operates.

[Impact Detection Alarm]:An alarm is activated when an impact is detected on the body.



[Notice]

- [Tamper Detection alarm] is displayed only when [Radar] is selected.
- [VMD alarm] and [Scene change detection (SCD) alarm] are only displayed when the [Cameras] is selected.

3.4.2 Operation when an alarm occurs

Displaying Alarm Notification in Live image pages

When an alarm occurs, an alarm notification is displayed on the [Live] page.

→[3.2.2 About Live image pages](#)

Notifying an Alarm to a Device Connected to the Output Terminal

An alarm occurs. This allows you to output a signal from the output terminal and sound an alarm, etc. You can set the signal-out in the [Alarm] section of the Alarms page. [Terminal state upon alarm detection], [Terminal action upon alarm detection], and "Pulse-output-time" can be set when "Radar self-diagnosis start" is selected for [Terminal 1].

→[6.1.5 Alarm: Setting output terminals](#)

SD store in the memory card

When an alarm occurs, images (H.265/H.264) are saved to the SD memory card. The settings for saving images to a SD memory card are configured in the [SD memory card] tab of the basic page and in the [Alarm] tab of the alarm page.

→[7.2 Setting an SD Memory Card \[SD Memory Card\]](#)

→[10.1 \[Alarm\] for setting alarm operations](#)

Notifying an Alarm by Email

When an alarm occurs, an alarm message (alarm notification) is sent to the registered e-mail address. You can store up to four alarm mail destinations. You can also send a still image as an attachment when sending Alarm Mail. You set up alarm emails in the [Alarm] tab of the Alarms page and in the [Advanced] tab of the Network page.

→[10.1 \[Alarm\] for setting alarm operations](#)

→ For details on sending e-mails, refer to the user manual.

Notify that an alarm has occurred at the specified address. (TCP alarm notification notification)

This function is available when using our equipment (such as a network disk recorder). When [TCP alarm notification] is set to [On], you can notify that the machine is in an alarm condition. You configure the TCP alarm notification settings in the [Transmission] section of the Alarms page. Refer to the User Manual for TCP alarm notification.

Notifying the specified HTTP server that an alarm has occurred (HTTP alarm notification)

When an alarm occurs, it is sent to the HTTP server registered in advance. You can register up to five notification destination HTTP servers. You can also set the URL to be sent when notifying the HTTP server. You configure HTTP alarms in the [Transmission] section of the Alarms page. For HTTP alarms, refer to the user manual.

3.5 Playing back images stored on a SD memory card

Clicking the time in the log list view will switch the Live image pages to the play page. The format varies depending on the [Recording format] of the SD memory card.



[Important]

- The image update speed may become slower during image playback or download.
- If there are many pictures stored on the SD memory card, it may take a while for the pictures to appear on the playback page.
- When the aspect ratio is set to [16:9], images saved on the SD memory card are displayed in [640x360] regardless of the Image capture size. Therefore, it may appear coarse on the playback page.
- When recording to a SD memory card, playing may be slow. • When playing back images recorded in H.265, if the recording bit rate is high, it may be displayed in the refresh rate.

3.5.1 Playing back images stored on a SD memory card



[Important]

- Depending on your network environment, video download may fail. If playback is in progress, you may be able to download it by stopping the playback and then executing it again.
- Depending on your network environment or the camera's status, you may not be able to perform operations continuously on this screen.

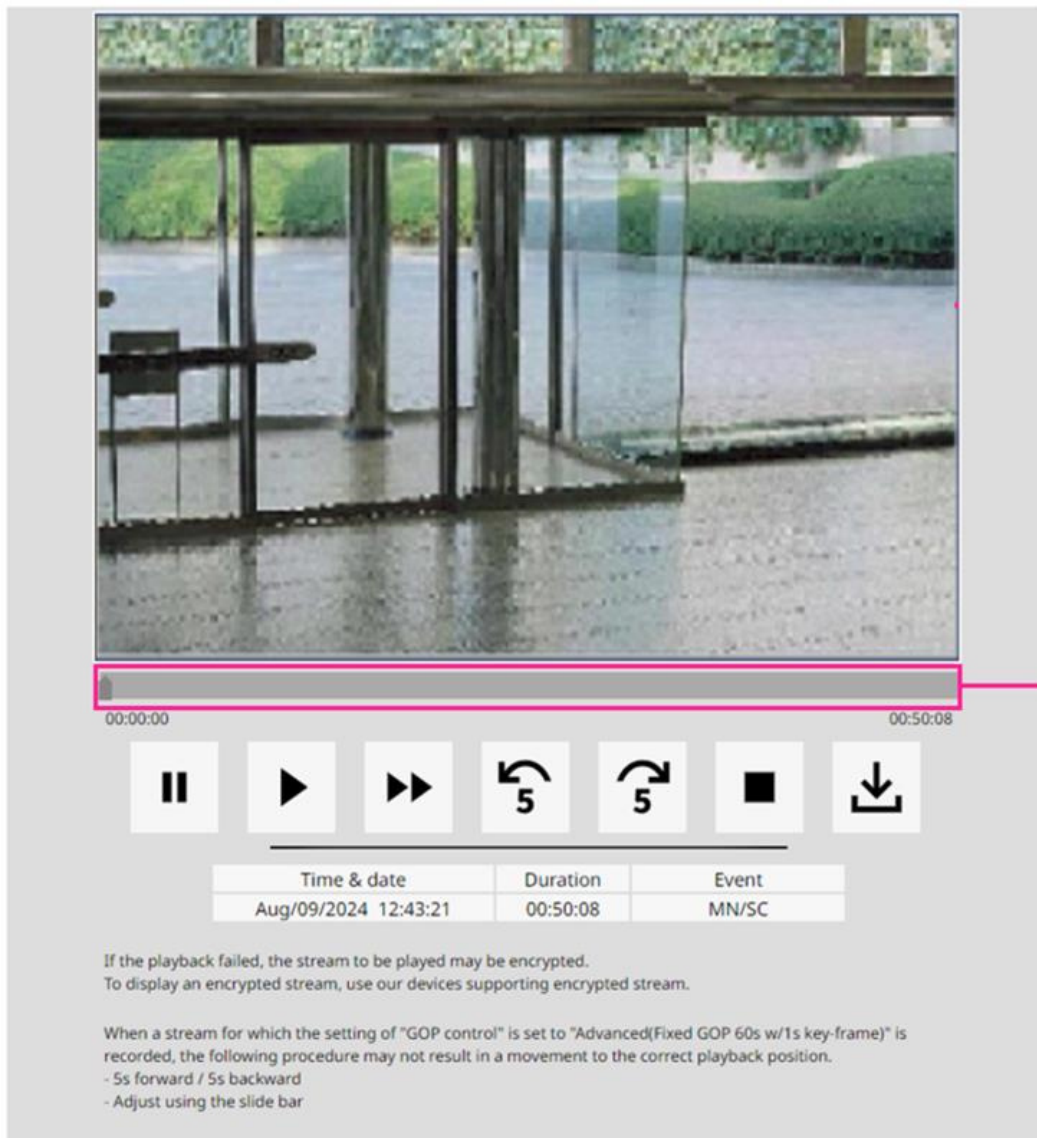

1. Slider bar

You can operate the slider bar to play back from any position. You can operate only before playback starts, during pause, and after playback ends.



[Notice]

- Move the slider bar to move to the I-picture at the position where you moved it. For this reason, if a stream with [GOP control] set to [Advanced (fixed GOP 60s + 1s keyframe)] is recorded, the position that can be moved is set to 60 seconds apart.

⏸ (Pause) button

Click during playback to pause playback.

▶ (Play) button

Plays back recorded data.



[Notice]

- When audio data is recorded, the recorded data is played back as well, but the image and audio are not synchronized. Therefore, there may be slight discrepancy between the image and sound. When recording to a SD memory card, audio playback may be interrupted or the sound quality may drop.
- When playing back recorded data, the speed of updating live images and playing back images may be slow.
- If the [Audio transmission mode] in the [Audio] section of the Video/Audio page is set to [Off] or [Interactive(Half-duplex)], recordings are not played back.

⏩ (High-speed playback) button

Each time you click the button, the playback speed changes.

During high-speed playback ▶ Click the button to return to normal playback speed.



[Notice]

- Depending on the [Stream recording]-[Max bit rate] setting of the SD memory card, the max. speed of high-speed playback varies.
- Recorded data is not played back during high-speed playback.
- Depending on the [Stream recording]-[Max bit rate] setting, the display may be delayed or the display time may be skipped during high-speed playback.

⏮ (5-second return) button

Each time the button is clicked, it returns to 5 seconds before and plays back the recorded data.



[Notice]

- If a stream with [GOP control] set to [Advanced (fixed GOP 60s + 1s keyframe)] is recorded, the playing position may return larger than 5 seconds depending on the duration of the recording of the I-picture.

 **(5-second feed) button**

Each time you click the button, the recordings will be played back in 5 seconds.



[Notice]

- If a stream with [Advanced (fixed GOP 60s + 1s keyframe)] set to [GOP control] is recorded, the playing position may return depending on the duration of recording of the I-picture.

▪ **(Exit) button**

Stops playing and returns to the Live image pages.

[Time]

Displays the date and time the log was recorded.

[Duration]

Displays the number of hours the data was saved to the SD memory card.

[Event]

Displays the cause of the log occurrence.

- MN/SC: Manual Save, Scheduled Save Logging
- TRM1: Alarm by inputting an alarm to terminal 1
- TRM2: Alarm by inputting an alarm to terminal 2
- TRM3: Alarm by inputting an alarm to terminal 3
- VMD: Alarm based on motion detection alarm
- SCD: Alarm by jamming detection or radar jamming detection alarm
- COM: Alarms by Command Alarms
- IMPACT: Alarms by impact detection alarms
- INSTALL: Alarm by an error detection alarm at the installation angle
- INT: Intrusion Alarms by Radar Detection
- LOI: Delay alarm by radar detection
- CLD: Line Cross Alarm with Radar Detection

 **(Download) button**

The selected recording is downloaded to the PC.

Check your browser settings for the directory where you want to save the PC.

 Click the button to display the download screen. In the download window, press [OK].



[Notice]

- You cannot operate the playback screen while downloading. Please operate after downloading is completed.
- If the [CANCEL] button is clicked during the download, the download is canceled. Videos downloaded prior to clicking [CANCEL] are saved to the PC.
- Since video data is saved in approximately 60 MB units of files, if the data exceeds the 60 MB, more than one file will be downloaded.
- H.264 videos saved in PC can be played back using Windows Media® Player, etc. However, we do not guarantee that the software will operate in any way.
- Depending on the status of the SD memory card or the Windows Media Player, you may not be able to play H.264 movies.
- For more information about playing back H.265 videos, see our Technical Info website.<Control No. :C0303>See also.

4 Setting

4.1 Opening the Settings pane from the PC

The main settings of the Security Radar are made in the settings pane.



[Important]

- The settings panel can be operated only by users with [1. Administrator] access level. For information on how to set the access level, refer to the user manual.

4.1.1 How to display

5 Displays the Live image pages.

→[3.2.2 About Live image pages](#)

6 In the Live image pages  Click the button to display the settings panel.

Press again to hide it. For more information about this panel, see the following:

→[4.1.3 About the settings panel screen](#)

4.1.2 How to operate

1 Click each tab in the Settings panel.

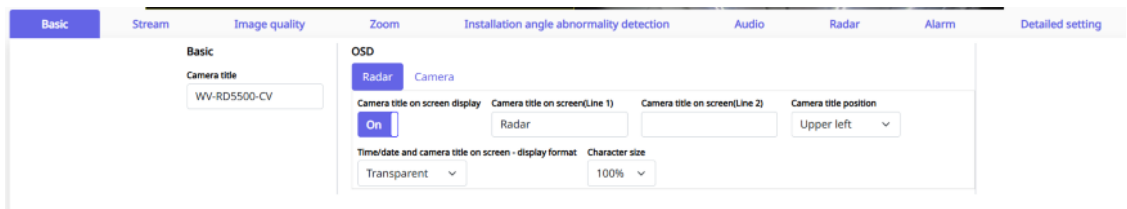

2 Enter each item on the setting page.



[Notice]

- Some items cannot be set depending on the display contents of the main area.

4 Setting

4.1 Opening the Settings pane from the PC

If the item you want to set is not displayed,  Click or use the scroll bar to display and enter the item you want to set.

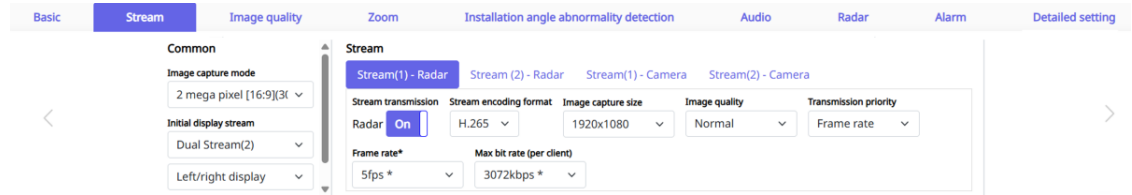

- 3 When you have finished typing, confirm your [Set] by clicking on it. Other items are confirmed when a setting value is selected.



[Important]

- If there is more than one [Set], [Activate Account], or [Execute] button on the page, click the [Set], [Activate Account], or [Execute] button for each item.

4.1.3 About the settings panel screen

Security Radar

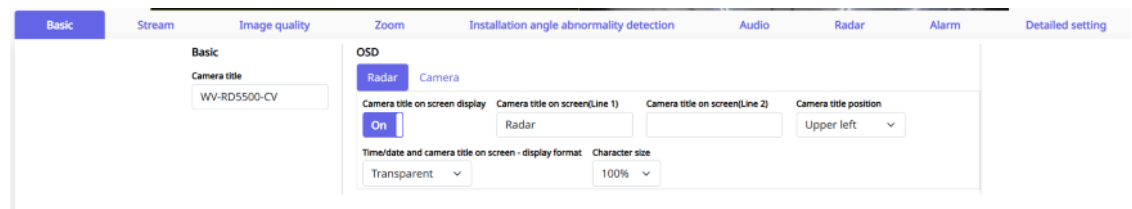

1. [Basic] tabbed page

Displays the [Basic] tabbed page. The [Basic] tab. You can configure settings such as the camera title and text.

→ [7 Advanced Settings Perform basic settings for this machine \[Basic\]](#)

2. [Stream numbers] tabbed page

Displays the [Stream numbers] tabbed page. Use the [Stream numbers] tabs to configure settings such as capture mode and streaming.

→ [8.3 Configuring Stream Settings \[Video\]](#)

3. [Quality] tabbed page

Displays the [Quality] tabbed page. The [Quality] tabbed page allows you to change settings such as image quality.

→ [8.4 Setting the image quality \[Quality\]](#)

4. [Zoom]Tab

Displays the [Zoom] tabbed page. The [Zoom] tab. Make zooming and other settings.

→[8.4.3 Adjust the digital zoom](#)



[Notice]

- Zoom is available only when using the camera.

5. **[Installation angle abnormality detection]Tab**

Displays the [Installation angle abnormality detection] tabbed page. On the [Installation angle abnormality detection] tab. Configure settings for error detection at the installation angle.

→[8.4.7 Setting Angle Error Detection](#)

6. **[Audio] tabbed page**

Displays the [Audio] tabbed page. On the [Audio] tabbed page, you can make settings related to audio.

→[8.5 Setting sound \[Audio\]](#)

7. **[Radar] tabbed page**

Displays the [Radar] tabbed page. On the [Radar] tab. Configure settings related to the radar.

→[9 \[Radar\] to set advanced radar settings](#)

8. **[Alarm] tabbed page**

Displays the [Alarm] tabbed page. On the [Alarm] tab. Configure settings related to alarms.

→[10 Advanced Alarm Settings \[Alarm\]](#)

9. **[Detailed setting] tabbed page**

Displays the [Detailed setting] tabbed page. On the [Detailed setting] tabbed page, you can move to the advanced settings and configure the operator panel settings.

→[7 Advanced Settings Perform basic settings for this machine \[Basic\]](#)



[Notice]

- If the snapshot takes longer than a certain amount of time to take, for example, due to a network environment, the image may not be displayed.
- If the JPEG of the specified Image capture size cannot be obtained, the JPEG images of the Image capture size that can be obtained are displayed.

Therefore, if you take a JPEG image in a snapshot and browse it in the PC, it may differ from the displayed image size.

4.2 Setting Radar [Radar]

On the [Radar] tab. Configure settings related to the radar. Check the Advanced Radar page for a detailed explanation of the settings and precautions when setting.

→9 [Radar] to set advanced radar settings

[Display settings]

Set the display settings of the radar.

- **[Radar Display Background Color]**
Sets the background of the semi-circle image that shows the area of the radar irradiation in [White] and [Gray].
- **[Radar Display Transparency]**
Set the transparency of the semi-circular images that indicate the radar area in [Off]–[90%].
- **[Show Track History]**
Select from [Off] to [24h] to display the trajectory data in the radar window.
- **[Show Raw Radar Data]**
Set the trajectory [Display] of the radar window with [On]/[Off].



[Notice]

- The point cloud data is the raw data before the radar is detected.

- **[Icon/Text Size]**
Set the [Icon/Text Size] from the [Large], [Medium], and [Small].
- **[Show Object Type]**
Set the [Show Object Type] in the [On]/[Off] of the [Display].
- **[Show Movement Speed]**
Set the [Show Movement Speed] in the [On]/[Off] of the [Display].

[PTZ Linkage]

- **[Registered PTZ Display]**
Set the [Registered PTZ Display] in the [On]/[Off] of the [Display].
- **[Display of important points]**

Set the [Display of important points] in the [On]/[Off] of the [Display].

4.3 Configuring settings related to installation angle errors [Installation angle error detection]

[\[Installation angle abnormality detection\]](#)

- **[Installation angle confirmation]**

Set the [Installation angle of view confirmation] in the [Display].

You can correct the position of the camera while checking the deviation from the position when the installation angle is registered.

- **[Angle of view registration]**

Set the [Execute] and [Delete] in the [Angle of view registration].

4.4 Setting Alarm [Alarm]

The [Alarm] tab. Configure settings related to alarms.

See the [Alarm] section of the Advanced Alarms page for a detailed description of the settings and notes on the settings.

→10 [Advanced Alarm Settings \[Alarm\]](#)

[\[Alarm\]](#)

Set terminal operation and alarm items.

- **[Terminal 1]**

Sets the operation of terminal 1.

- **[Terminal 2]**

Sets the operation of terminal 2.

- **[Terminal 3]**

Sets the operation of terminal 3.

- **[Tamper Detection alarm]**

Set whether to use the [On] or [Off] for detecting radar jamming.

When set to [On], Radar Denial Detection is enabled. If you want to configure additional settings for Radar Denial Detection, you can do so in the [Tamper Detection] section of the Advanced Alarms page.

→[9.7 \[Radar Settings\] for setting radar disturbance detection](#)

The [Tamper Detection] tab of the Advanced Alarms page can be accessed from the Live Drawing link.

- **[VMD alarm]**

Set whether to perform operation detection with [On]/[Off].

When [On] is set, all areas are specified in the operation detection area. If you want to specify an action detection area, you can configure it in the [VMD area] section of the Advanced Alarms page.

→[10.5 \[VMD area\] to set operation detection](#)

The [VMD area] tab of the Advanced Alarms page can be accessed from the Live Drawing link.

- **[Scene change detection (SCD) alarm]**

Set whether to detect disturbance using [On]/[Off].

When set to [On], specifies the entire disturbance detection area. If you want to specify any disturbance detection area, configure it in the [SCD area] section of the Advanced Alarms page.

→[10.7 \[SCD area\] for configuring disturbance detection](#)

The [SCD area] tab of the Advanced Alarms page can be accessed from the Live Drawing link.



[Notice]

- [Tamper Detection alarm] is displayed only when [Radar] is selected.
- [VMD alarm] and [Scene change detection (SCD) alarm] are only displayed when the [Cameras] is selected.

- **[Audio detection alarm]**

Use the [On] and [Off] buttons to specify whether or not sound detection is performed.

When set to [On], all sound-identifying objects are enabled. If you want to configure detailed settings for sound detection, you can do so in the [Audio detection] section of the Advanced Alarms page.

→[10.9 \[Audio detection\] for configuring sound detection settings](#)

The [Audio detection] tab of the Advanced Alarms page can be accessed from the Live Drawing link.

- **[Shock detection alarm]**

impact detection.

When set to [On], impact detection is enabled. When setting the details of impact detection, set it in the [Impact Detection] tab of the alarm page of the detail setting.

→[10.10 To set impact detection \[Impact Detection\]](#)

The [Impact Detection] tab on the Advanced Alarm page can be accessed via the link in the

live image.

- **[Alarm deactivation time]**

Set the length of time that the detection operation is not performed after an alarm is detected.

For example, if you set an alarm to send an email notification to your mobile device or tablet, this setting prevents you from sending too many emails.

5 Displaying the Advanced Settings menu of the Security Radar from the PC

The Security Radar settings are configured in the Settings menu.



[Important]

- The setting menu can be operated only by users with [1. Administrator] access level. For information on how to set the access level, refer to the user manual.

5.1 How to display

- 1 Displays the Live image pages.
→ [3.2.2 About Live image pages](#)
- 2 Display the settings panel.
- 3 Select the [Detailed setting] tab..
- 4 Clicking the [Detailed setting] key displays the advanced settings menu.

For more information on this menu, please read:

→ [5 Displaying the Advanced Settings menu of the Security Radar from the PC](#)

5.2 How to operate

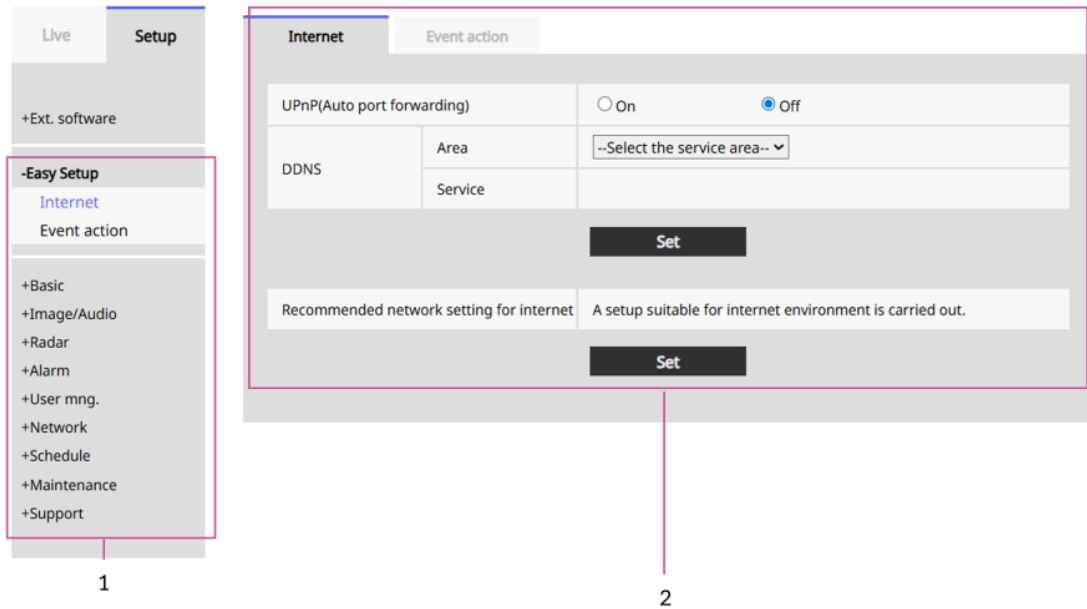

1. Menu button

2. Configuration page

1. Click the menu button on the left side of the screen to display the setting page.
If the page consists of multiple tabs, click each tab.
2. Enter each item on the setting page.
3. When you are finished, confirm your entry by clicking [Set].



[Important]

- If there is more than one [Set], [Activate Account], or [Execute] button on the page, click the [Set], [Activate Account], or [Execute] button for each item.

<Example>

The screenshot shows the 'Internet' settings page with two tabs: 'Internet' and 'Event action'. The 'Internet' tab is active. The settings are organized into two columns. Column A contains 'UPnP(Auto port forwarding)' with radio buttons for 'On' and 'Off' (selected), and 'DDNS' with sub-fields for 'Area' (a dropdown menu showing '--Select the service area--') and 'Service'. Column B contains a message: 'Recommended network setting for internet' and 'A setup suitable for internet environment is carried out.' Below each column is a black 'Set' button. Annotations on the right side of the image point to these elements: 'A' points to the DDNS section, 'A-1' points to the 'Set' button below column A, 'B' points to the message box, and 'B-1' points to the 'Set' button below column B.

When you have finished setting the items in column A, press the [Set] button (A-1) below column A.

If you do not press the [Set] key (A-1) below the A field, the settings will not be confirmed.

When you have finished setting the B column items as described above, press the [Set] button (B-1) below the B column.

5.3 Camera Settings Menu Screen

Security Radar

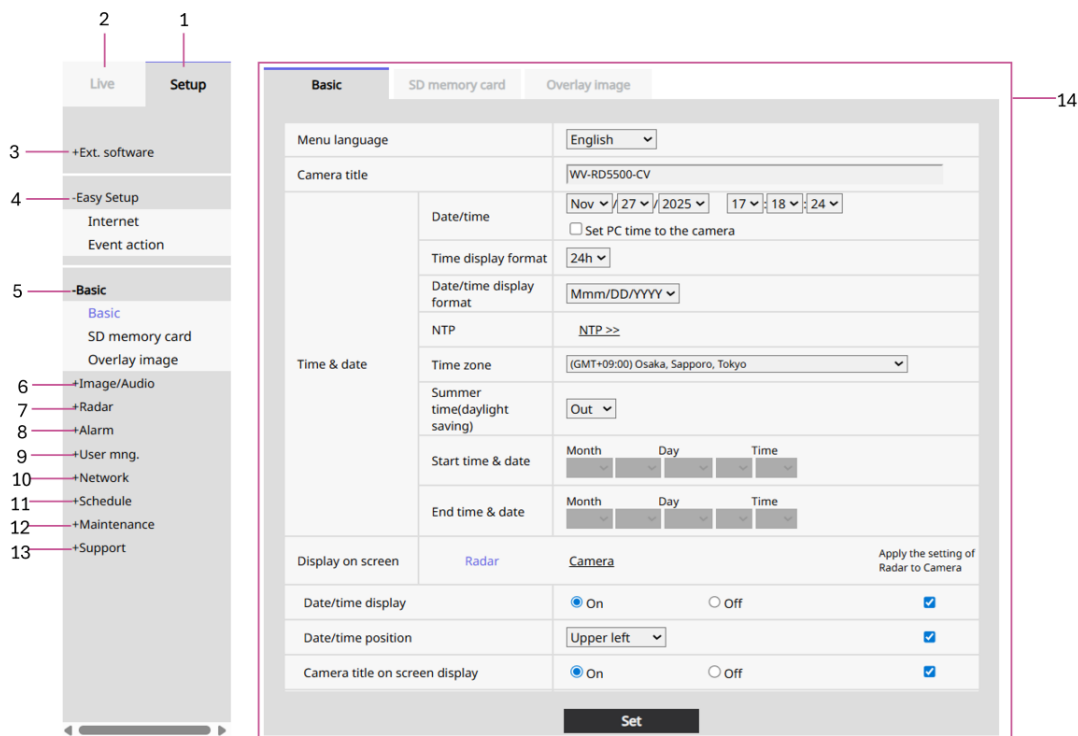

1. **[Setup] button**
Indicates the setup menu.
2. **[Live] button**
Displays the Live image pages.
3. **[Ext. software] button**
Extension software can be managed and scheduled. Also, if you installed Extension software, you will be prompted to do so. Refer to the user manual for details.
4. **[Easy Setup] button**
The easy setting page is displayed. On the Easy Setup page, you can set Internet disclosure settings and event operations such as alarm settings and alarm linked operation. Refer to the user manual for details.
5. **[Basic] button**
Displays the basic page. Basic settings such as date and time, camera title, and SD memory card-related settings can be configured.
→ [7 Advanced Settings Perform basic settings for this machine \[Basic\]](#)
6. **[Image/Audio] button**

Displays the Video/Audio page. In the Video/Audio page, you can make camera-related settings such as the image quality and Image capture size of JPEG/H.265/H.264 images.

→[8.5 Setting sound \[Audio\]](#)

7. **[Radar] button**

Displays the radar page. On the Radar page, you can configure the radar settings, the PTZ linkage, the radar detection, and the radar disturbance detection.

→[9 \[Radar\] to set advanced radar settings](#)

8. **[Alarm] button**

Displays the alarm page. On the alarm page, you can set the alarm operation and operation detection area when an alarm occurs, set the disturbance detection area, set the impact detection alarm, set the sound detection alarm, and set the alarm notification.

→[10 Advanced Alarm Settings \[Alarm\]](#)

9. **[User mng.] button**

Displays the User Management page. On the User Login page, you can specify authentication/data encryption settings to restrict users and PC accessing this machine. Refer to the user manual for details.

10. **[Network] button**

Displays the Network page. The Network page is used to configure the network-related settings and DDNS(Dynamic DNS (SNMP(Simple Network Management Protocol), NTP server, and UPnP, HTTPS, QoS, SRTP, MQTT, LLDP.

→[11 Advanced Networking Settings \[Network\]](#)

11. **[Schedule] button**

The Schedule page is displayed. On the Schedule page, you can set up a schedule for operation detection permission, disturbance detection permission, and sound detection permission.

→[12 \[Schedule\] to set advanced scheduling](#)

12. **[Maintenance] button**

Displays the Maintenance page. On the Maintenance page, you can check the system log, upgrade the software, check the status, and initialize the instrument settings. Refer to the user manual for details.

13. **[Support] button**

The Support page is displayed. The support page provides information on how to access our support website. Refer to the user manual for details.

14. **[Setting Page]**

The page for each setting menu is displayed. Some menus have multiple tabs. The bottom part of the setting page is omitted from the screen.

6 Advanced settings

6.1 To set event operation [Event Operation]

On the Easy Setup page, select [Event action]. For details on how to display and operate the Setting menu, refer to the following.

→[4.1.1 How to display](#)

→[4.1.2 How to operate](#)

Here, you can check the current settings of the event operation.

Internet **Event action**

Configure the event action setting.
Specify the action to be taken when an alarm is detected and register the action in the schedule in order.

[Current settings]

Alarm	
Alarm condition	Off
Alarm	Off
Output terminal	Off
E-mail notification	Off

Schedule	
Schedule	Off

[Notes]
• When the operating condition is changed, some settings will be cancelled. Confirm the settings after completing the setup.

Next

The event action allows you to set the event action for SD scheduled recording or alarm detection. After completing the settings in the settings window, click [Next] to proceed.

The setup process is as follows.



[Notice]

- Clicking [Next] saves the settings in the window.

Event Operation Flow

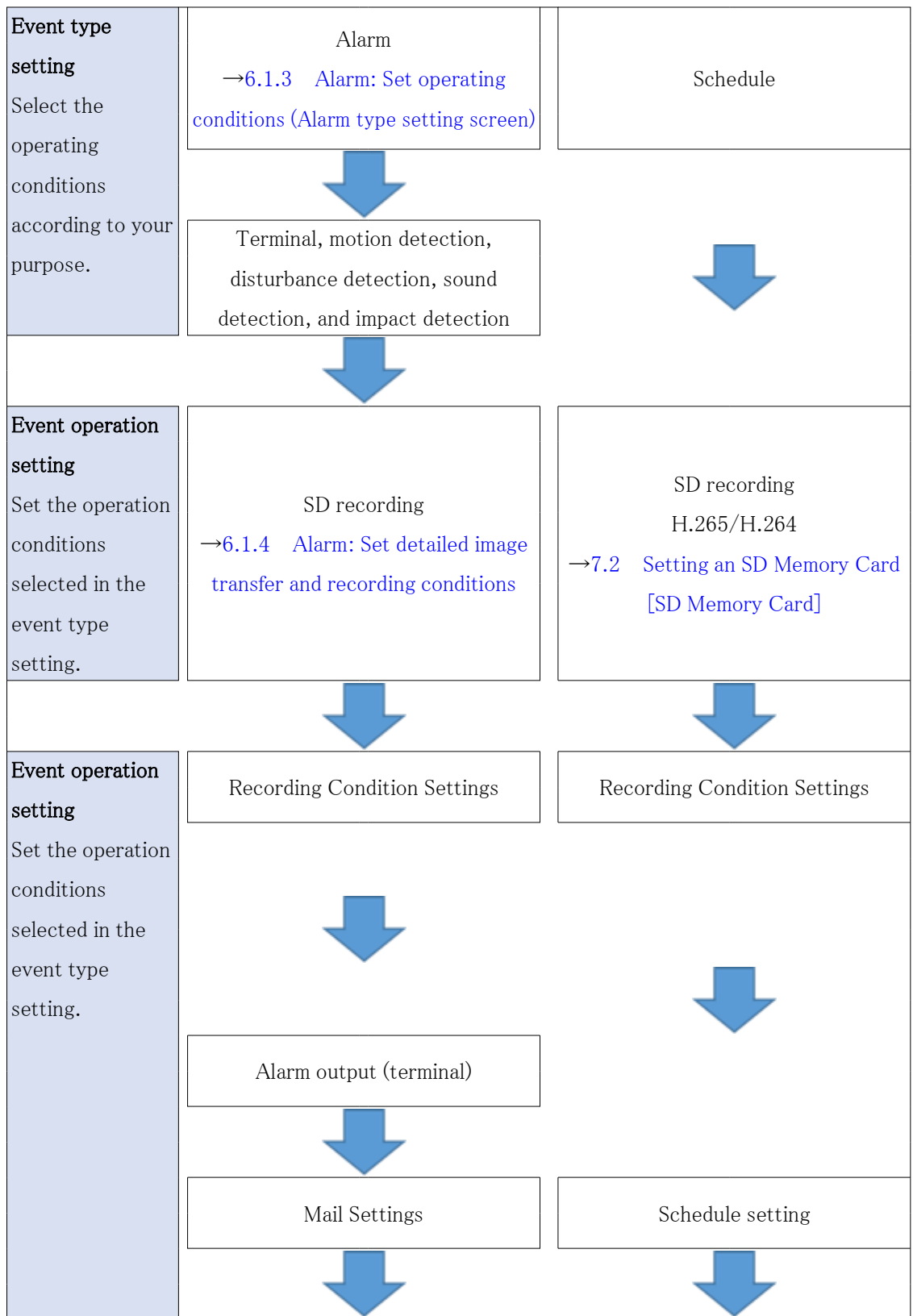

6 Advanced settings

6.1 To set event operation [Event Operation]



6.1.1 Setting Schedule/Alarm (Event Type Setting Screen)

Here you select the type of event.

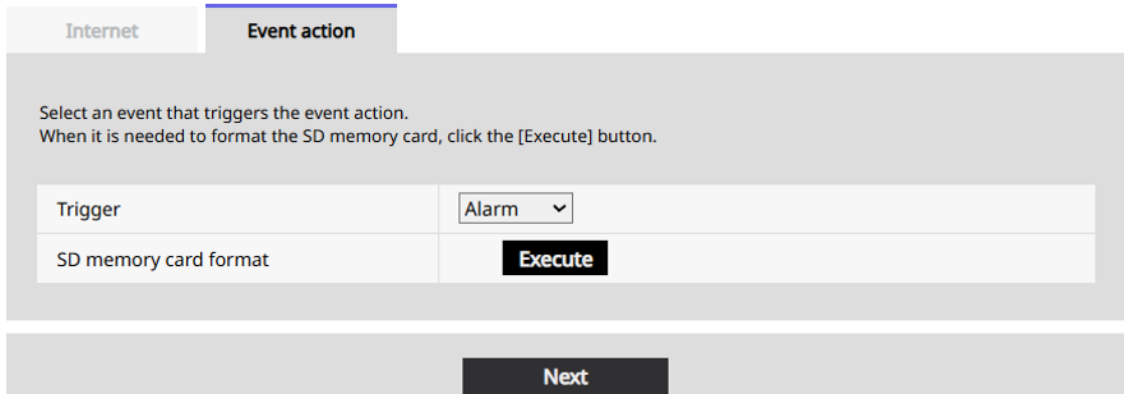

[Trigger]

[Alarm]: Select when setting for alarm detection.

[Schedule]: Select this item when [SD memory recording] is selected.

[SD memory card format]

To format a SD memory card, press [Execute].

Clicking [Execute] displays the [Format] confirmation window.

Press [OK] to begin formatting.

When the [Format] Complete window appears, press [x].



[Important]

- Formatting will delete all files on the SD memory card.
- Do not turn off this unit during formatting.

[Next] button

Select [Alarm] and press [Next] to open the Alarm Settings window.

→ [6.1.2 Alarm: Setting the terminal and operation detection \(Alarm setting screen\)](#)

Select [Schedule] and click [Next] to open the Schedule Type Setting window.

→ [12 \[Schedule\] to set advanced scheduling](#)

6.1.2 Alarm: Setting the terminal and operation detection (Alarm setting screen)

Here, the operation when an alarm is detected is set.

Internet
Event action

Configure the alarm condition to be used for the alarm detection.
The whole area of area 1 is to be set as the detection area for the motion detection alarm.
The whole area is to be set as the detection area for SCD alarm.

Alarm	
Terminal 1	<input type="text" value="Off"/> ▼
Terminal 2	<input type="text" value="Off"/> ▼
Terminal 3	<input type="text" value="Off"/> ▼
VMD alarm	<input type="radio"/> On <input checked="" type="radio"/> Off
SCD alarm	<input type="radio"/> On <input checked="" type="radio"/> Off
Audio detection alarm	<input type="radio"/> On <input checked="" type="radio"/> Off
Impact detection alarm	<input type="radio"/> On <input checked="" type="radio"/> Off
Alarm deactivation time	<input type="text" value="5"/> s (5-600s)

Back
Next

Alarm

[Terminal 1]

Sets the operation of terminal 1.

- **[Off]**: Pin functions are not used.
- **[Alarm input(TRM1)]**: Accepts terminal alarm input.
- **[Close]**: Alarm is detected when the pin status changes to [Close].
- **[Open]**: Alarm is detected when the pin status changes to [Open].
- **[Close(Continue)]**: Alarm is detected when the pin status changes to [Close]. When the pin status is [Close], the alarm is detected periodically at the alarm non-detection interval.
- **[Open(Continue)]**: Alarm is detected when the pin status changes to [Open]. When the pin status is [Open], the alarm is detected periodically at the alarm non-detection interval.
- **[Radar]**: Operates as radar alarm input.
- **[Cameras]**: Operates as an alarm input for the camera.
- **[Radar Self check Start]**: You can check whether the radar is operating normally.
- **[Close]**: Radar self-test starts when the pin status changes to [Close].
- **[Open]**: Radar self-test starts when the pin status changes to [Open].
- **[Black & white input]**: Accepts black and white switching input. (Switches to black and white when the entry is [On].)
- **[Auto time adjustment]**: Accepts the time setting by terminal input. If the time difference from

the hour (every hour 00 minutes) is within 29 minutes, set to 00 minutes 00 seconds. If the time is less than 5 seconds during SD recording, the time is not changed. When "AUTO TIME ADJUST" is selected, the short-circuit and open selection pull-down menus are displayed.

- **[Close]**: When the pin status changes to [Close], the watch automatically adjusts the time.
- **[Open]**: When the pin status changes to [Open], the watch automatically adjusts the time.



[Reference]

- When terminal 1 is selected as [Self-diagnosis start], the result is output to terminal 3 according to the setting.

[Terminal 2]

Sets the operation of terminal 2.

- **[Off]**: Pin functions are not used.
- **[Alarm input (TRM2)]**: Accepts terminal alarm input.
- **[Short-circuit]**: Alarm is detected when the pin status changes to [Close].
- **[Open]**: Alarm detection is performed when the terminal status changes to [Open].
- **[Short (Continued)]**: Alarm is detected when the pin status changes to [Close]. When the pin status is [Close], the alarm is detected periodically at the alarm non-detection interval.
- **[Open (Continue)]**: Alarm is detected when the pin status changes to [Open]. When the pin status is [Open], the alarm is detected periodically at the alarm non-detection interval.
- **[Radar]**: Operates as radar alarm input.
- **[Cameras]**: Operates as an alarm input for the camera.
- **[Alarm output]**: Alarm is outputted according to the content set in [Output terminal].
- **[Radar]**: Outputs when an alarm is detected by the radar.
- **[Cameras]**: Outputs when an alarm is detected on the camera.

→ [10.2 \[Alarm\] for setting pins](#)

[Terminal 3]

Sets the operation of terminal 3.

- **[Off]**: Pin functions are not used.
- **[Alarm input (TRM3)]**: Accepts terminal alarm input.
- **[Short-circuit]**: Alarm is detected when the pin status changes to [Close].
- **[Open]**: Alarm is detected when the pin status changes to [Open].
- **[Short (Continued)]**: Alarm is detected when the pin status changes to [Close]. When the pin status is [Close], the alarm is detected periodically at the alarm non-detection interval.
- **[Open (Continue)]**: Alarm is detected when the pin status changes to [Open]. When the pin status is [Open], the alarm is detected periodically at the alarm non-detection interval.

- **[Radar]**: Operates as radar alarm input.
- **[Cameras]**: Operates as an alarm input for the camera.
- **[Alarm output]**: Alarm is outputted according to the content set in [Output terminal].
- **[Radar]**: Outputs when an alarm is detected by the radar.
- **[Cameras]**: Outputs when an alarm is detected on the camera.
- **[AUX out]**: Performs AUX export. Displays the [AUX] in the Live image pages.



[Reference]

- [Radar Self check Output] is displayed only when [Radar Self check Start] is selected at terminal 1.
- In [Self-diagnosis result output], if the input from pin 1 is output to pin 3, it is normal. If the input from terminal 1 is not output to terminal 3, an error occurs.

[VMD alarm]

[On]: If the operation detection area is not set, set the entire area. To set the operation detection area, set it on the [VMD area] tab. on the Alarm page.

→ [10.6 \[VMD area\] to set operation detection area](#)

[Off]: Disables all operation detection conditions.

[Scene change detection (SCD) alarm]

[On]: If the disturbance detection area is not set, set the entire area. If you want to configure the disturbance detection area, you can do so in the [SCD area] section of the Alarms page.

→ [10.8 \[SCD area\] to set the disturbance detection area](#)

[Off]: Disables all intrusion detection conditions.

[Audio detection alarm]

[On]: Use a sound detection alarm. All sound identifications are enabled.

→ [10.9 \[Audio detection\] for configuring sound detection settings](#)

[Off]: Sound detection alarm is not used.

[Impact detection alarm]

[Use the On/Off to set whether or not to perform impact detection.

[On]: Enables impact detection.

→ [10.10 To set impact detection \[Impact Detection\]](#)

[Off]: Disables impact detection.

[Alarm deactivation time]

Set the length of time that the detection operation is not performed after an alarm is detected. For example, if you set an alarm to send an email notification to your mobile device or tablet, this setting prevents you from sending too many emails.

[0.5 sec, 1–600 sec]



[Notice]

- Alarm detection time is managed for each alarm type. For example, the operation detection alarm is detected even during the alarm non-detection time of terminal alarm 1.

[Next] button

[Click the [Next] button to display the alarm type setting screen.

→[6.1.1 Setting Schedule/Alarm \(Event Type Setting Screen\)](#)



[Notice]

- Clicking [Next] saves the settings in the window.

[Back] button

Returns to the previous screen.

6.1.3 Alarm: Set operating conditions (Alarm type setting screen)

Here, you can set the operation to be performed when an alarm is detected.

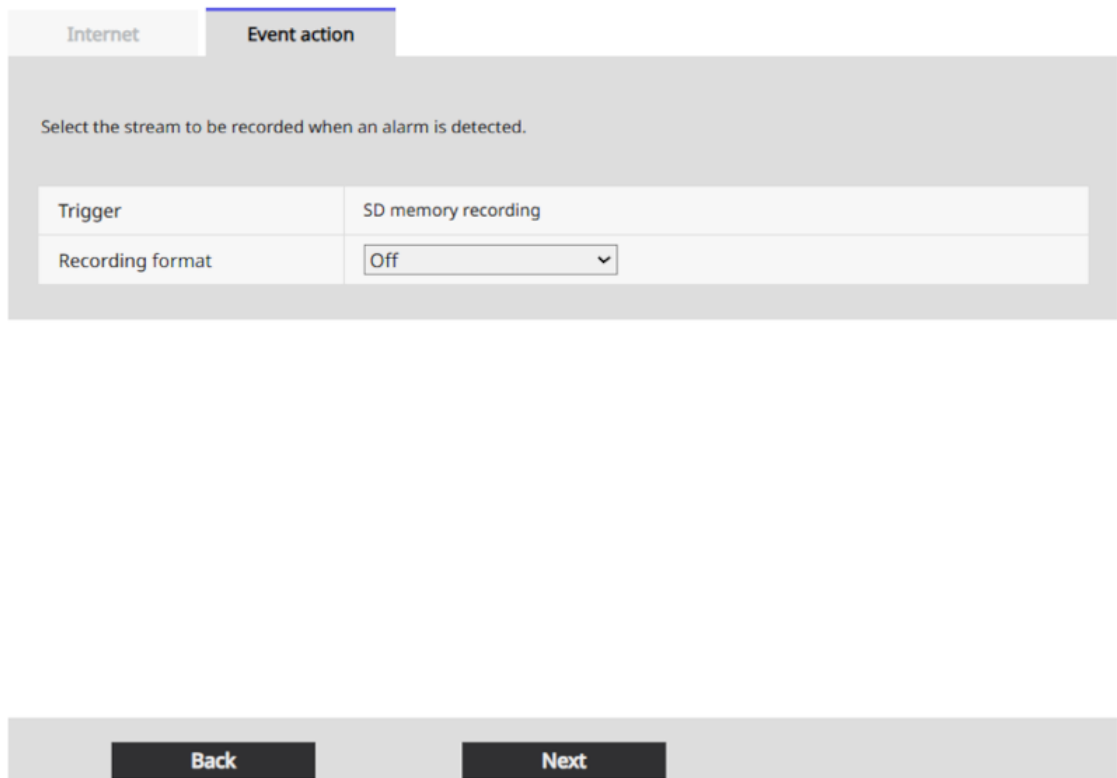

[Recording format]

When [SD memory recording] is selected for [Trigger], select the compression method for the image to be recorded from [Stream (1) Radar/Camera] and [Stream (2) Radar/Camera].

[Next] button

Select [SD memory recording] in [Trigger] or Stream in [Recording format] and press [Next] to open the Video Recording Settings window.

→ [6.1.4 Alarm: Set detailed image transfer and recording conditions](#)



[Notice]

- Clicking [Next Step] saves the settings in the window.
- Sound detection alarms cannot be recorded in the SD memory card.

[Back] button

Returns to the previous screen.

6.1.4 Alarm: Set detailed image transfer and recording conditions

[Setting SD Recording \(H.265 or H.264\) \(Video Recording Setting Window\)](#)

Here, you can set the SD recording (H.265 or H.264) when an alarm is detected.

Internet	Event action
Configure the recording condition of the SD memory recording when an alarm is detected.	
Stream recording(Alarm)	
Audio recording	<input type="radio"/> On <input checked="" type="radio"/> Off
Frame rate*(Radar)	5fps * v
Frame rate*(Camera)	30fps * v
Pre alarm (recording) duration	Off v
Post alarm (recording) duration	30s v

Back **Next**

[Audio recording]

Use [On]/[Off] to select whether to record audio data.

[On]:You can save audio files to movies (MP4 formats).

[Off]:Audio files are not saved in movies (MP4 formats).



[Notice]

- This cannot be set when the audio delivery mode is set to bidirectional (half-duplex).

[Frame Rate* (Radar)]

Set the frame rate of the H.265 (or H.264) to record.

[Frame Rate* (Camera)]

Set the frame rate of the H.265 (or H.264) to record.



[Notice]

- See [Frame rate*] below for the configurable frame rate and the bit rate to be set depending on the frame rate.

→6.1.7 SCHEDULE: Set SD Recording (Video Recording Setting Window)

[Pre alarm (recording) duration]

Select whether to record before an alarm occurs. Sets how long SD memory cards are saved.

[Off] / [1s] / [2s] / [3s] / [4s] / [5s] / [8s] / [10s] / [15s] / [20s] / [25s] / [30s] / [40s] / [50s] / [60s]



[Notice]

- The available settings depend on the Image capture size and bitrate of the streams you are recording. The higher the bit rate, the smaller the maximum value that can be set as the pre-alarm time.

[Post alarm (recording) duration]

Set how long to save to the SD memory card after an alarm occurs.

[10s] / [20s] / [30s] / [40s] / [50s] / [60s] / [120s] / [180s] / [240s] / [300s]

[Next] button

Select [Alarm output] in the Alarm Settings window and click [Next] to open the Alarm Out Settings window.

→ [6.1.5 Alarm: Setting output terminals](#)

If you do not select [Alarm output] in the Alarm Settings window and then click [Next], the Mail Settings window appears.

→ [6.1.6 Alarms: Set up email notifications and mail servers](#)



[Notice]

- Clicking [Next] saves the settings in the window.

[Back] button

Returns to the previous screen.

6.1.5 Alarm: Setting output terminals

Here, set the alarm output. Displayed when [Alarm output] is selected in the alarm setting window.

When making settings related to output connectors:

Set the action of the output terminal when an alarm is detected.
When "Latch" is selected for "Alarm output type", the alarm output is cancelled by clicking the alarm occurrence indication button in the "Live" page.

Output terminal	
Terminal output upon alarm detection	<input type="radio"/> On <input checked="" type="radio"/> Off
SD memory card error	<input type="radio"/> On <input checked="" type="radio"/> Off
Terminal state upon alarm detection	<input checked="" type="radio"/> Latch <input type="radio"/> Pulse
Terminal action upon alarm detection	<input type="radio"/> Open <input checked="" type="radio"/> Close
Pulse output width	<input type="text" value="1"/> s (1-120s)

For details on how to set the above screen, refer to the following.

→[10.2 \[Alarm\] for setting pins](#)

[Next] button

[Click the [Next] button to display the mail setting screen.

→[6.1.6 Alarms: Set up email notifications and mail servers](#)



[Notice]

• Clicking [Next] saves the settings in the window.

[Back] button

Returns to the previous screen.

6.1.6 Alarms: Set up email notifications and mail servers

Here, you can make settings related to mail.

6 Advanced settings

6.1 To set event operation [Event Operation]

Internet
Event action

Set the method of mail notification when an alarm is detected.

E-mail notification	
E-mail notification	<input type="radio"/> On <input checked="" type="radio"/> Off
Alarm image attachment	<input type="radio"/> On <input checked="" type="radio"/> Off
Image capture size	1920x1080

SMTP server address	<input style="width: 100%;" type="text"/> Example of entry: 192.168.0.10
SMTP port	<input style="width: 100%;" type="text"/> (1-65535)
POP server address	<input style="width: 100%;" type="text"/> Example of entry: 192.168.0.10
Authentication	Type <input checked="" type="radio"/> None <input type="radio"/> POP before SMTP <input type="radio"/> SMTP
	User name <input style="width: 100%;" type="text"/>
	Password <input style="width: 100%;" type="text"/>
Sender's E-mail address	<input style="width: 100%;" type="text"/>
SSL	<input type="radio"/> On <input checked="" type="radio"/> Off

Destination of notification	Destination E-mail address
Address 1	<input style="width: 100%;" type="text"/> Delete <input type="checkbox"/> Terminal 1 <input type="checkbox"/> Terminal 2 <input type="checkbox"/> Terminal 3 <input type="checkbox"/> VMD <input type="checkbox"/> SCD <input type="checkbox"/> Audio detection <input type="checkbox"/> Impact detection <input type="checkbox"/> Installation angle abnormality detection <input type="checkbox"/> Radar detection <input type="checkbox"/> Tamper Detection <small>* For alarms by the "Ext. Software", e-mail notification will be provided only by configuring the destination e-mail address setting.</small>
Address 2	<input style="width: 100%;" type="text"/> Delete <input type="checkbox"/> Terminal 1 <input type="checkbox"/> Terminal 2 <input type="checkbox"/> Terminal 3 <input type="checkbox"/> VMD <input type="checkbox"/> SCD <input type="checkbox"/> Audio detection <input type="checkbox"/> Impact detection <input type="checkbox"/> Installation angle abnormality detection <input type="checkbox"/> Radar detection <input type="checkbox"/> Tamper Detection <small>* For alarms by the "Ext. Software", e-mail notification will be provided only by configuring the destination e-mail address setting.</small>
Address 3	<input style="width: 100%;" type="text"/> Delete <input type="checkbox"/> Terminal 1 <input type="checkbox"/> Terminal 2 <input type="checkbox"/> Terminal 3 <input type="checkbox"/> VMD <input type="checkbox"/> SCD <input type="checkbox"/> Audio detection <input type="checkbox"/> Impact detection <input type="checkbox"/> Installation angle abnormality detection <input type="checkbox"/> Radar detection <input type="checkbox"/> Tamper Detection <small>* For alarms by the "Ext. Software", e-mail notification will be provided only by configuring the destination e-mail address setting.</small>
Address 4	<input style="width: 100%;" type="text"/> Delete <input type="checkbox"/> Terminal 1 <input type="checkbox"/> Terminal 2 <input type="checkbox"/> Terminal 3 <input type="checkbox"/> VMD <input type="checkbox"/> SCD <input type="checkbox"/> Audio detection <input type="checkbox"/> Impact detection <input type="checkbox"/> Installation angle abnormality detection <input type="checkbox"/> Radar detection <input type="checkbox"/> Tamper Detection <small>* For alarms by the "Ext. Software", e-mail notification will be provided only by configuring the destination e-mail address setting.</small>
E-mail subject(Alarm)	<input type="checkbox"/> Use the camera title <input type="checkbox"/> Cause of alarm <input style="width: 100%;" type="text"/>
E-mail subject(Diag.)	<input type="checkbox"/> Use the camera title <input style="width: 100%;" type="text"/>
E-mail body(Alarm)	<input checked="" type="checkbox"/> Cause of alarm <input checked="" type="checkbox"/> Occurrence time <input style="width: 100%;" type="text"/>

Back
Set

For details on how to set the screen above, refer to the User's Manual.

[Set] button

Clicking the [Set] key completes the settings.

[Back] button

Returns to the previous screen.

6.1.7 **SCHEDULE: Set SD Recording (Video Recording Setting Window)**

Here, you set up scheduled SD recording (H.265 or H.264).

Clicking [Next Step] after setting the recording or frame rate in the video recording settings screen displays the scheduling screen and allows you to set the schedule.

- 1 Set the recording, frame rate, and SD memory card overwrite settings in the video recording settings window.

6 Advanced settings

6.1 To set event operation [Event Operation]

Internet **Event action**

Set the recording method of the SD memory recording to be registered in the schedule.

Stream recording	
Audio recording	<input type="radio"/> On <input checked="" type="radio"/> Off
Frame rate*(Radar)	5fps * ▾
Frame rate*(Camera)	30fps * ▾
Overwrite	<input checked="" type="radio"/> On <input type="radio"/> Off

Back **Next**

[Audio recording]

Set whether to record voice data.

[On]: You can save audio files to movies (MP4 formats).

[Off]: Audio files are not saved in movies (MP4 formats).



[Notice]

- This cannot be set when the audio delivery mode is set to bidirectional (half-duplex).



[Important]

- If there is insufficient space on the SD memory card when [Overwrite] is switched from [Off] to [On], older images may be deleted in preparation for writing.

[Frame Rate* (Radar)]

Set the frame rate of the H.265 (or H.264) to be recorded.

-If [Image Capture Mode] is set to 30fps/25fps:

1fps / 3fps / 5fps*

[Frame Rate*(Camera)]

Set the frame rate of the H.265 (or H.264) to be recorded.

-If [Image Capture Mode] is set to 30fps:

1fps / 3fps / 5fps* / 7.5fps* / 10fps* / 12fps* / 15fps* / 20fps* / 30fps*

-If [Image Capture Mode] is set to 25fps:

1fps / 3.1fps / 4.2fps* / 6.25fps* / 8.3fps* / 12.5fps* / 20fps* / 25fps*



[Notice]

- Clicking [Next] button sets the [Transmission priority] to [Frame rate].

The bit rate is automatically set according to the selected Image capture size and frame rate. For the set bit rate, check the [Bit Rate per Client*] setting of each stream.

[Overwrite]

Sets whether to overwrite images when the free space on the SD memory card is low.

[On]: When the SD memory card becomes full, you can overwrite older images and save them again.

[Off]: If the SD memory card runs out of space, saving to the SD memory card is stopped.



[Important]

- If there is insufficient space on the SD memory card when [Overwrite] is switched from [Off] to [On], older images may be deleted in preparation for writing.

[Next] button

Clicking [Next Step] displays a window for scheduling the recording to the SD memory card.

[Back] button

Returns to the previous screen.

- 2 Set the schedule in the schedule setting screen.

6 Advanced settings

6.1 To set event operation [Event Operation]

Internet **Event action**

Select "Recording to SD (Recording stream)" for "Schedule mode" of the schedule (1 - 5) to be registered, and set the recording schedule.
When "Recording to SD (Recording stream)" is not select for "Schedule mode", recording will not be performed.

Schedules	Schedule mode	Time range
Schedule 1 (White) <input type="checkbox"/>	Off	<input type="checkbox"/> Mon <input type="checkbox"/> Tue <input type="checkbox"/> Wed <input type="checkbox"/> Thu <input type="checkbox"/> Fri <input type="checkbox"/> Sat <input type="checkbox"/> Sun <input type="checkbox"/> 24h
Schedule 2 (Blue) <input type="checkbox"/>	Off	<input type="checkbox"/> Mon <input type="checkbox"/> Tue <input type="checkbox"/> Wed <input type="checkbox"/> Thu <input type="checkbox"/> Fri <input type="checkbox"/> Sat <input type="checkbox"/> Sun <input type="checkbox"/> 24h
Schedule 3 (Green) <input type="checkbox"/>	Off	<input type="checkbox"/> Mon <input type="checkbox"/> Tue <input type="checkbox"/> Wed <input type="checkbox"/> Thu <input type="checkbox"/> Fri <input type="checkbox"/> Sat <input type="checkbox"/> Sun <input type="checkbox"/> 24h
Schedule 4 (Red) <input type="checkbox"/>	Off	<input type="checkbox"/> Mon <input type="checkbox"/> Tue <input type="checkbox"/> Wed <input type="checkbox"/> Thu <input type="checkbox"/> Fri <input type="checkbox"/> Sat <input type="checkbox"/> Sun <input type="checkbox"/> 24h
Schedule 5 (Black) <input type="checkbox"/>	Off	<input type="checkbox"/> Mon <input type="checkbox"/> Tue <input type="checkbox"/> Wed <input type="checkbox"/> Thu <input type="checkbox"/> Fri <input type="checkbox"/> Sat <input type="checkbox"/> Sun <input type="checkbox"/> 24h
Schedule 6 (Yellow) <input type="checkbox"/>	Off	<input type="checkbox"/> Mon <input type="checkbox"/> Tue <input type="checkbox"/> Wed <input type="checkbox"/> Thu <input type="checkbox"/> Fri <input type="checkbox"/> Sat <input type="checkbox"/> Sun <input type="checkbox"/> 24h
Schedule 7 (Light blue) <input type="checkbox"/>	Off	<input type="checkbox"/> Mon <input type="checkbox"/> Tue <input type="checkbox"/> Wed <input type="checkbox"/> Thu <input type="checkbox"/> Fri <input type="checkbox"/> Sat <input type="checkbox"/> Sun <input type="checkbox"/> 24h
Schedule 8 (Purple) <input type="checkbox"/>	Off	<input type="checkbox"/> Mon <input type="checkbox"/> Tue <input type="checkbox"/> Wed <input type="checkbox"/> Thu <input type="checkbox"/> Fri <input type="checkbox"/> Sat <input type="checkbox"/> Sun <input type="checkbox"/> 24h

Scene settings linked to sunrise and sunset times [To scene setting \(image quality adjustment\)](#)
When using this function, set the time zone. [Basic settings >>](#)

Auto Scheduler (Manual/ City Selection)	Not use
Latitude	(+90.000000 - 90.000000)
Longitude	(-180.000000 - 180.000000)
Altitude	m(-500 - 9000)
Automatic calculation result	Sunrise time : Sunset time :
Sunrise time and sunset time correction	Sunrise time + Minutes (-60 - 60) Sunset time + Minutes (-60 - 60) The time of the automatic calculation result can be corrected between -60 minutes and +60 minutes.

	0:00	6:00	12:00	18:00	24:00
Mon					
Tue					
Wed					
Thu					
Fri					
Sat					
Sun					

The color of each schedule is not linked with the area color of "VMD area".
When "VMD permission" is set, the VMD functions in all the areas set with "VMD area".
"VMD permission" and "SCD permission" are required when assigning the period to be detected. Setting is not necessary when detection at any time.

Back **Set**

For details on how to set the screen above, refer to the following.

→12 [\[Schedule\] to set advanced scheduling](#)

[Set] button

Clicking the [Set] key completes the settings.

[Back] button

Returns to the previous screen.



[Notice]

•If [SD memory recording] is not selected in [Operation Mode], recording is not performed.

7 Advanced Settings Perform basic settings for this machine [Basic]

The basic settings include camera titles, date and time settings, SD memory cards, and overlays. The basic page consists of the [Basic] tab, [SD memory card] tab, and [Overlay Image] tab.

7.1 Perform basic settings [Basic]

Click the [Basic] tab on the base page. Refer to the User's Manual for details on how to display and operate the advanced settings menu.

Here, you can set the camera title, date and time, etc.

[Menu language]

Choose the first language that appears when you access the camera:

[Auto]/[English]/[Japanese]/[Italian]/[French]/[German]/[Spanish]/[Chinese]/[Russian]/
[Portuguese]

[Auto]: The language used in the browser is automatically selected. If this machine does not support the language, English will be selected.

[Camera Title]

Enter the name of this machine. After inputting, clicking [Set] will display the entered name in the title.

Number of characters that can be entered: 0 to 20 characters

Characters that cannot be entered: Half-pitch symbols " &

[Date]

Enter the current date and time. If you selected [12h] for [Time display format], select [AM] or [PM].

When [Set PC time to the camera] is checked and [Set] is clicked, the PC date and time are acquired and set to this machine.

Setting range : Jan/01/2013 00:00:00 ~ Dec/31/2035 23:59:59



[Important]

• If more accurate time settings are required for system operation, use a NTP server.

For the setting method, refer to the user manual.

[Date/time display]

Use the [On] and [Off] buttons to specify whether the date and time are displayed on images. Set to [Off] if the date and time are not to be displayed.

[Time display format]

Select how the time is displayed from the 24h/12h. Enter [Date] according to this setting.

[Date/time display format]

Select the date display format. When [Date] is set to [April 1, 2022 at 13:10:00 seconds], the display formats are as follows.

DD/MM/YYYY: 01/04/2022 13:10:00

MM/DD/YYYY: 04/01/2022 13:10:00

DD/Mmm/YYYY: 01/Apr/2022 13:10:00

YYYY/MM/DD: 2022/04/01 13:10:00

Mmm/DD/YYYY: Apr/01/2022 13:10:00

[Date/time position]

Select the position to display the date and time on the image.

[Upper left] : Appears at the top left of the window.

[Lower left] : Appears at the bottom left of the window.

[Upper center] : Displayed at the top center of the window.

[Lower center] : Displayed at the bottom center of the window.

[Upper right] : Appears in the upper-right corner of the window.

[Lower right] : Appears at the bottom right of the window.

[NTP]

Clicking [NTP >>] displays the [Advanced] tab of the Network page.

For the setting method, refer to the User's Manual.

[Time zone]

Select the time zone that suits the region of the camera you are using.

[Summer time(daylight saving)]

Set whether to use daylight saving time by [In]/[Out]/[Auto]. Set the time zone where daylight saving time is used.

[In]: Set the time to daylight saving time. [*] is displayed on the time display.

[Out]: The daylight saving time is canceled.

[Auto]: Switches to Daylight Saving Time according to the start date and time and end date and time settings (month, week, day of the week, and time).

[Start time & date] [End time & date]

When [Auto] is selected in the [Summer time(daylight saving)] setting, set the start and end dates and times of daylight saving time by month, week, day of the week, and time.

[Display on screen]

To configure settings individually, select [Radar]/[Cameras] to configure the settings.

By checking [Reflect Radar Settings to All] the display set on the radar side can be set to the same on the camera side.

[Date/time display]

[Date/time position]

[Camera title on screen display]

[Camera title position]

[Camera title on screen display]

Set whether to show text on images with [On]/[Off].

When set to [On], the text entered in [Camera title on screen] is displayed in the position selected in [Position].

[Camera title position]

Selects the position of the text displayed in the image.

[Upper left]: Display at the top left of the screen.

[Lower left]: Display at the bottom left of the screen.

[Upper center]: Display at the top center of the screen.

[Lower center]: Display at the bottom center of the screen.

[Upper right]: Display at the top right of the screen.

[Lower right]: Display at the bottom right of the screen.

[Camera title on screen]

Enter the character string to be displayed in the image.

[Radar]

[Line 1]/[Line 2]

[Cameras]

[Line 1]/[Line 2]

Number of characters that can be entered: 0 to 40 characters

Available Characters : Half-width (0 to 9, A to Z, a to z), full-width (kanji, hiragana, katakana, alphanumeric), half-width/full-width symbol ! " # \$ % & ' () * + , - . / : ; = ?



[Notice]

- Up to two lines of [Camera title on screen] can be set.

[OSD]–[Display type]

Set the display format to either [Permeation] or [Opaque].

[Permeation]:Displays the date and time and the characters on the screen in transparent characters.

[Opaque]:Displays the date and time and the characters on the screen in non-transparent characters (white text on a black fill).

[OSD]–[Character size]

Selects the character size of the date/time and character string displayed in the image.

50%: Displays at the standard 50% size.

75%: Displays at the standard 75% size.

100%: Displays in the standard size.

150%: Displays at 150% of the standard size.

200%: Displays at 200% of the standard size.



[Important]

- If the [Date/time position] and [Camera title position] settings differ, the frame rate may be lower than the set value.
- If the [Date/time position] and [Camera title position] settings differ, the characters may be cut or overlapped depending on the [Character size] setting and the number of characters. Please use after confirming the display result.
- If [Character size] is set to [150%] or [200%], the frame rate may be lower than the set value.
- Depending on the setting of [Character size] and the number of characters, or the Image capture size of the picture, it may be displayed only halfway or difficult to read. Please use after confirming the display result.



[Notice]

- Even when 50% and 75% are set, [Camera title on screen] is displayed at 100% size on the 640x360, 320x180 images.
- When [Overlay] of [Detailed setting] is set to [On], [X]&[150%] and [200%] cannot be set in [Character size].

[Brightness status display]

Set the On/Off to show the brightness when adjusting the brightness.



[Notice]

- The in-image display of the brightness state is displayed when the brightness is adjusted by the system device.

[Indicator]

Select whether to turn the lamp on or off. Select [On] when you want to check the operation status with the indicator.

[On]: Turns on constantly when set.

[Off]: Turns off at all times when set.

7.2 Setting an SD Memory Card [SD Memory Card]

Click the [SD memory card] tab on the base page. Refer to the User's Manual for details on how to display and operate the advanced settings menu.

Here, you can make settings related to SD memory cards.

Operational mode

[SD memory card]

Specify whether to use the SD memory card or not.

[Ext. software mode]

If the installed Extension software uses the SD memory card of this unit, set this setting to [On].

[On]: Extension software will be able to use this unit's SD memory card.

[Off]: Extension software is unable to use this unit's SD memory card.



[Notice]

- When setting the Extension software mode from [On] to [Off], it is recommended to format the SD memory card.
- Recording functions to a SD memory card cannot be guaranteed when the Extension software is operated with a SD memory card.

[SD Memory Card File System Format]

You can select the file system format of the SD memory card. This can be selected only when [Ext. software mode] is set to [On].

[FAT(FAT16/FAT32/exFAT)]: Use FAT format SD memory cards.

[ext(ext4)]: Use ext format SD memory cards.



[Important]

- If you have changed the [SD Memory Card File System Format], format the SD memory card by clicking [Format]'s [Execute] key.



[Notice]

- If you select [ext(ext4)], you can use the SD memory card only in Extension software.

Therefore, functions such as recording to the SD memory card, recording function and SD memory card remaining space notification will not be available.

- If you select [ext(ext4)], the SD memory card's historical data will be deleted on the [Status] tab. You will not be able to view the data.
- If you select [ext(ext4)], the capacity of the SD memory card cannot be displayed.
→ Refer to the user manual for details.

[Audio]

Set whether to record audio when saving videos in MP4 format.

[Off]: Audio files are not saved in movies (MP4 formats).

[On]: You can save audio files to movies (MP4 formats).



[Notice]

- If you use [Audio], you must set the [Recording format] to streaming.

[Remaining capacity notification]

When using the e-mail notification function or TCP alarm notification notification function to notify the remaining space of the SD memory card, select the number of percent of free space to be notified when it reaches.

50% / 20% / 10% / 5% / 2%



[Notice]

- Remaining space notification is notified for each remaining space value less than or equal to the set value.

For example, when [50%] is set, notification is made when the remaining capacity reaches 50%, 20%, 10%, 5%, or 2%. The timing of notification may be slightly offset.

[Overwrite]

Sets whether to overwrite images when the free space on the SD memory card is low.

[On]: When the SD memory card becomes full, you can overwrite older images and save them again.

[Off]: If the SD memory card runs out of space, saving to the SD memory card is stopped.



[Important]

- When not using a SD memory card, set to [No].
- Before removing a SD Memory Card from the Digital Piano, be sure to set it to [No] first.

Removing the SD memory card from the camera while the camera is in the [Yes] mode may damage the data.

- When [Yes] is selected and a SD memory card is inserted, the data is saved according to the [Save trigger] setting.
- After inserting the SD memory card, set it to [Yes].
- If the image update speed is fast, the timing and interval of notifications and recordings may be shifted.

Also, if multiple users receive images, notifications and recordings may not be performed as configured.

In this case, make the image update speed slower.

- The SD memory card has a limit on the number of rewrites. If the rewrite frequency is high, the life may be shortened.
- The life of a SD memory card is affected by the number of image files saved to the SD memory card and the number of log writes.
- By selecting a stream in [Recording format] and setting a smaller value for [Bit rate per client*] of the stream to be recorded, the number of files to be saved in the SD memory card can be reduced.
- If the number of writes to the SD memory card increases and the writing rate decreases, we recommend that you replace the SD memory card with a new one.
- If there is insufficient space on the SD memory card when switching from [Off] to [On], older images may be deleted in preparation for writing.

SD Memory Card Security Settings

[Additional info for detecting alteration]

Sets whether to add data that can be detected when data on the SD memory card is tampered with.

Only video (MP4 formats) are available for tampering and can be checked with the dedicated software.

Dedicated software for tampering detection and its use are on our technical information website.

<Control No. :C0304>See also.

[Detailed Settings]>>Click the] button to display the setting screen for adding tampering detection information in a separate window.

→[7.2.1 Detection of tampering](#)

[SD memory card password lock]

Set a password for the SD memory card. Once a password is set, devices other than this unit cannot write to or read from the SD memory card.

If your SD memory card is stolen or lost, you can reduce the chance of the data being leaked.

[Set]

If a SD memory card with no password is inserted, the password can be set using the Set button.

[password] / [Retype password]

Type a password.

Number of characters that can be entered:4 to 16 characters

Characters that cannot be entered:Two-byte or one-byte symbol"&

[Cancel]

If a SD memory card with a password has been inserted, you can cancel the password by pressing the Release button.

[password]

Type a password.

Number of characters that can be entered:4 to 16 characters

Characters that cannot be entered:Two-byte or one-byte symbol"&

[Change]

If a SD memory card with a password has been inserted, you can change the password by pressing the Change button.

[Old password] / [New Password] / [Retype new password]

Type a password.

Number of characters that can be entered:4 to 16 characters

Characters that cannot be entered:Two-byte or one-byte symbol"&

[Status]

Displays the password lock setting status.

[While locked]:The password is assigned to the SD memory card and the locking function is enabled.

[Not set]: Lock function is disabled

Also displays the password setting status of the SD memory card.

[Password set]: The password has been successfully set.

[Error (incompatible SD memory card)]: A card that does not support password lock is inserted.

Check that a SDHC memory card or SDXC memory card is inserted.

[Error (password mismatch)]: The password set for the SD memory card does not match the password set for this unit, so you cannot use the SD memory card.

Make sure that the password is correct.

[Error (other error)]: This message appears when an error has occurred in the SD memory card.

Check the SD memory card.



[Notice]

- Only the SDHC memory card or SDXC memory card supports the password lock function.
- If you use a SD memory card with password lock set on a device other than this unit, release the password with the password lock release button, and then remove the SD memory card. Passwords cannot be canceled by PC or other non-camera devices.
- When [SD memory card password lock]'s [Status] is set to [Lock] and a SD memory card with no password set is inserted into the Digital Piano, a password is automatically assigned to the SD memory card.



[Important]

- If you forget the set password, you cannot cancel the password. The SD memory card to which the password has been set cannot be used, so keep it in mind.
- If you forget the set password and replace the SD memory card with a new one, please set [SD memory card password lock]'s [Status] to [Not been set] in either of the following steps.
 - Enter the password with the Release button and press the Set button.
 - Initialize the setting value from the maintenance page.

Recording stream

[Recording format]

Select the type of images to be saved on the SD memory card.

[Off]: Does not save image data.

[Stream (1) Radar/Camera]: Save the video (streamed (1)) in MP4 format. Saves data according to

the [Stream(1)] setting in the [Image] tab. on the Video/Audio page.

[Streams (2)Radar/camera]: Save the video (streamed (2)) in MP4 format. Saves data according to the [Stream(2)] setting in the [Image] tab. on the Video/Audio page.



[Important]

- Use a SD memory card that supports speed class Class10 that is compatible with UHS-I (Ultra High Speed-I).
- It is recommended to use a microSD memory card dedicated to i-PRO devices.
- If you are using a SD memory card that does not support speed class Class10, set the [Recording format] bit-rate to 6144 kbps.
- If you are using a SD memory card that supports speed class Class10, make sure that the bitrate of the stream selected by [Recording format] is 12288 kbps.



[Notice]

- When [Stream numbers] is selected, the [Stream numbers] setting in [Image] on the Video/Audio page is set to [Stream].&Switches to Movie recording setting.
- If you change the [Recording format] setting to [Stream numbers], the settings of the following functions may be corrected.
 - If [Transmission priority] was set to [Best effort], it is set to [Frame rate].
 - Set to [1s] if [Refresh interval] was set to [2s], [3s], [4s], or [5s].
- If [Recording format] is [Stream numbers], the file name of the file to be saved is automatically assigned.
- If the [Recording format] is [Stream numbers], you might have fewer users available to connect.
- When [Audio] is set to [On], the maximum bit rate that can be set for a stream is limited.
- When [Additional info for detecting alteration] is set to [On], the maximum bit rate that can be set for a stream is limited.

[Save trigger]

Select how to save images to the SD memory card.

[Alarm input]: Save an image when an alarm occurs.

[Manual save]: Save the image manually.

[Schedule]: Save the image according to your schedule settings. Available only when [Stream numbers] is selected in [Recording format].

→6.1 To set event operation [Event Operation]

If you selected [Alarm input] for [Save trigger], you can select the alarm type from the following:

[terminal 1]: Save the image when an alarm occurs at terminal 1.

[Terminal 2]: Save the image when an alarm occurs at terminal 2.

[Terminal 3]: Save the image when an alarm occurs at terminal 3.

[VMD]: The image is saved when an operation detection occurs.

[SCD]: Save the image when disturbance detection occurs.

[Impact Detection]: Save the image when an impact is detected.

[Command alarm]: Saves an image when a command alarm is entered.

[Installation angle abnormality detection]: Save the image when an installation angle error is detected.

[Radar detection]: Save the image when a radar detection occurs.

[Tamper Detection]: Save the image when a radar jam detection occurs.



[Notice]

- To generate an alarm, set the alarm on the [Alarm] tab.
- [Save trigger] may appear as Gray Out in the [Network failure] when connected to a Tektronix network disk recorder. To change the [Save trigger] setting after disconnecting from the recorder, set [SD memory card] to [No] and then [Yes] again.
- Streams with [Advanced (fixed GOP 60s + 1s keyframe)] set to [GOP control] cannot be set to alarm recording.
- When an alarm for sound detection occurs, video is not recorded.

Movie recording (when an alarm occurs)

Stream recording(Alarm)	
Pre alarm (recording) duration	Off ▾
Post alarm (recording) duration	30s ▾

This item can be set only when [Recording format] of the SD memory card is set to Stream and [Save trigger] is set to [Alarm input].

[Pre alarm (recording) duration]

Select whether to record before an alarm occurs. Sets how long SD memory cards are saved.

[Off] / [1s] / [2s] / [3s] / [4s] / [5s] / [8s] / [10s] / [15s] / [20s] / [25s] / [30s] / [40s] / [50s] / [60s] / [90s] / [120s]



[Notice]

- The available settings depend on the Image capture size and bitrate of the streams you are recording. The higher the bit rate, the smaller the maximum value that can be set as the pre-alarm time.

[Post alarm (recording) duration]

Set how long to save to the SD memory card after an alarm occurs.

[10s] / [20s] / [30s] / [40s] / [50s] / [60s] / [120s] / [180s] / [240s] / [300s]

- ※ The actual recording time may be longer than the time set in the post alarm time.

SD Memory Card Info

[Remaining capacity]

The remaining and total capacity of the SD memory card are displayed.

The following message may appear depending on the status of the SD memory card.

In the display	Description
-----MB / -----MB	No SD memory card is inserted. Otherwise, the remaining capacity cannot be acquired due to a read error.
*****MB / *****MB	The SD memory card is not formatted.
#####MB / #####MB	Password locks on the SD memory card cannot be canceled.



[Notice]

- When [Overwrite] is set to [Off], images will not be saved to the SD memory card if the remaining space on the SD memory card becomes [0MB].

The notification function can be used to notify the specified e-mail address or TCP alarm notification notification destination when the free space on the SD memory card runs out.

→ Refer to the user manual for details.

[Format]

To format a SD memory card, press [Execute].

Formats the file in the file format selected in [SD Memory Card File System Format].



[Notice]

- When formatting a SD memory card by selecting [ext(ext4)] in [SD Memory Card File System Format], formatting may take up to 20 minutes, depending on the SD memory card.

- After formatting the SD memory card in ext format, check the operation of the

Extension software that uses the SD memory card.



[Important]

- Prior to formatting, set [SD memory card] on the base page to [Yes].
 - Be sure to format a SD memory card before using it in [SD memory card] mode.
- The following functions may not work properly when formatted with a device other than [SD memory card].
- Saving/Acquiring an Image When an Alarm Occurs
 - Saving/Retrieving images when saving manually
 - Storing/Retrieving Images Using the Schedule Function
 - Alarm log, Manual/Schedule save log, System log save/retrieve
 - Storing and acquiring images using the SD memory recording function of our network disk recorder
 - Playing back and downloading images stored on a SD memory card
- If another user is in the process of formatting, the process is interrupted.
 - SD memory card cannot be written while formatting is in progress.
 - Formatting will delete all files on the SD memory card.
 - Do not turn off this unit during formatting.
 - After formatting, the initial directory required for operation is created on the SD memory card. Therefore, the remaining capacity is displayed as less than the total capacity.
 - It is recommended to use a SD memory card dedicated to i-PRO devices.
 - Use a reliable and durable SD memory card when you use the auto-overwrite function to store images on a SD memory card repeatedly.
 - If your SD memory card supports speed class Class10, use a card that supports UHS- I (Ultra High Speed-I).

7.2.1 Detection of tampering

If tampering detection is enabled, data on the SD memory card can be detected using the dedicated software. If tampering occurs.

Only video files (MP4 formats) can be tampered with.

For details on how to set tampering detection, refer to the support video page of the support site.

<Control No.:P0001>See also.

Dedicated software for tampering detection and its use are on our technical information website.

<Control No. :C0304>See also.

Alteration detection	
Select certificate	Pre-installed ▾
Additional info for detecting alteration	<input type="radio"/> On <input checked="" type="radio"/> Off
Set	
Pre-installed certificate	
Certificate download	Execute
CA Certificate	
CRT key generate	Execute
Generate Certificate Signing Request	Execute
CA Certificate install	ファイルを選択 選択されていません Execute
Information	Invalid Confirm Delete
Certificate download	Execute
Close	

Alteration detection

[Select certificate]

Select the certificate used for tampering detection.

[Pre-installed]: Select a pre-installed certificate.

[CA]: Select the CA certificate. Displayed only if the CA certificate is installed.

[Additional info for detecting alteration]

Sets whether to add data for detecting tampering to video files (MP4 formats) to be saved on the SD memory card.

Pre-installed certificate

[Certificate download]

Click the Execute button to download the root certificate for the preinstalled certificate. The downloaded certificate is used to detect tampering with movies (MP4 files) on the SD memory card with the dedicated software.

CA certificates

[CRT key generate]

Generates the CRT key (encryption key) used for tampering detection.

The CRT key is generated in the [CRT Key Generation Dialog] that is displayed when the [Execute] key is clicked.

[Generate Certificate Signing Request]

When you use a CA certificate issued by a certificate authority as the CA certificate used for tampering detection, you generate a signing request (CSR:Certificate Signing Request) to apply to the certificate authority.

Signature request (CSR) generation is performed in [Signature request (CSR) generation dialogue] that is displayed when [Execute] is clicked.

[CA Certificate install]

Installs a certificate (CA certificate) issued by a certificate authority and displays the installed certificate (CA certificate).

Select the file of the certificate (CA certificate) issued by the certification authority from the [Open File Dialog] that is displayed when the [Select File] button is clicked, and then click the [Execute] button to install the certificate (CA certificate).

If a certificate (CA certificate) is installed, the filename of the installed certificate is displayed.

[Information]

Displays the certificate (CA certificate) issued by the certificate authority.

Clicking [Leave] displays the registered information of the installed certificate (CA certificate) in the [CA Certificate Confirmation Dialog].

Clicking [Delete] deletes the installed certificate (CA certificate).

[Certificate download]

The certificate (CA certificate) issued from the certificate authority is downloaded from this machine.

The downloaded certificate is used to detect tampering with movies (MP4 files) on the SD memory card with the dedicated software.



[Important]

- When deleting a valid certificate (CA certificate), make sure that the certificate (CA certificate) is backed up on the PC, recording media, etc. You will need a certificate (CA certificate) to install it again.

For details on how to set tampering detection, refer to the support video page of the support site.
<Control No.:P0001>See also.

7.3 Setting an overlay image [Overlay image]

The overlay image function is a function to embed images uploaded to this unit into live images (overlay display).

Click the [Overlay Image] tab on the base page. Refer to the User's Manual for details on how to display and operate the advanced settings menu.

Here, you can make settings related to the overlay image function.

Overlay image	Camera
Overlay	<input type="radio"/> On <input checked="" type="radio"/> Off
Image Selection	ファイルを選択 選択されていません Execute
Position	X <input type="text"/> Y <input type="text"/>
Permeation	<input type="radio"/> On <input checked="" type="radio"/> Off
Selection of color to be penetrated	Color Selection R:255,G:255,B:255 <input type="text"/>

* In case of upload of overlay image and drag of overlay image, the setting will be immediately reflected.
* If "Character size" of "OSD" is "150%" or "200%", "Overlay image" is not selectable.

Set

[Overlay]

Use the [On] and [Off] buttons to specify whether the uploaded images are overlaid.

[On]: Displays an overlay. When set to [On], the overlaid images are recorded even when

recording to a SD memory card.

[Off]: Does not display overlays.



[Notice]

- If [150%] or [200%] is selected for the [Character size] in the [Date and Time] window, the [Overlay] cannot be set.

[Image selection]

Follow the procedure below to upload the image file to be overlaid.

- 1) Select the image file saved in the PC by clicking [Select File].
- 2) Click [Execute] to upload the selected image file to the recorder. When an image file is uploaded, the uploaded image is overlaid on the setting screen.

Image files with the following specifications are available for overlay display.

- Image format: 256-color bitmap (BMP: Windows format)
- Image size: 24 pixels × 24 pixels–512 pixels × 512 pixels
- File size: 257 Kbyte or less



[Notice]

- Save the image file in a folder that does not use space or full-width characters. Files saved in folders that use spaces or double-byte characters may not be uploaded.



[Important]

- Do not turn off the digital piano or operate it while an image file is being uploaded.
- The upload image displayed will be reduced depending on the Image capture size of the live image. The image quality of the uploaded image may be degraded and displayed. Check the overlaid image in Live image pages.
- Upload images are saved when they are uploaded.

[Position]

The display position of the uploaded image (upper left corner of the image) is displayed in [X] and [Y] coordinates.

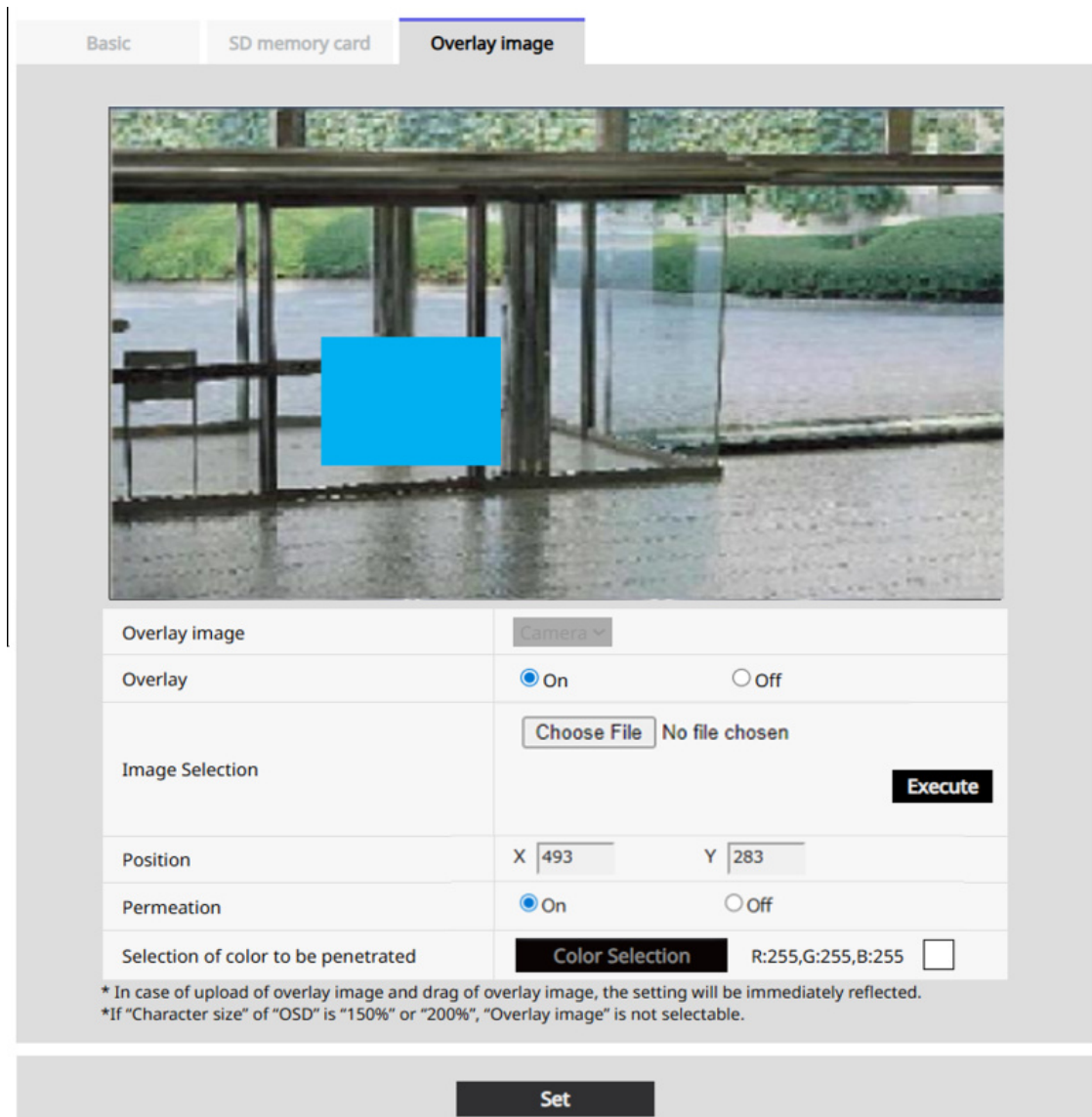

There are two ways to change the display position of uploaded images:

- Drag and drop the displayed upload image with the mouse.
- Enter the coordinates in [X] and [Y], and then press [Set].

Numbers that can be entered

X:0 ~ (639 minus the size next to the upload image)

Y:0 ~ (359 minus the vertical size of the uploaded image)



[Notice]

- You can change the display position by moving the red frame that appears when you drag an upload image.
- The coordinates that the upload image display extends beyond the setting screen cannot be set.

- If you move the uploaded image with the mouse, the displayed position is saved without clicking [Set].
- Even if you move the uploaded image to the edge of the screen, a gap may be created between the edges of the screen.



[Important]

- After changing the [Image Capture Mode] settings, check the position of the uploaded images. If the display position is misaligned, set the display position again. If the uploaded image is displayed outside the setting screen, the display position will return to the default (center of the live image).

[Permeation]

Use [On]/[Off] to set whether the colors selected in [Selection of color to be penetrated] are transparent.

[On]: Transmits the colors selected in the [Selection of color to be penetrated].

[Off]: The colors selected in [Selection of color to be penetrated] are not transparent.

[Selection of color to be penetrated]

Use the following procedure to select the color you want to transparent.

- 1 Clicking [Color Selection] displays a sub-window with the uploaded images.

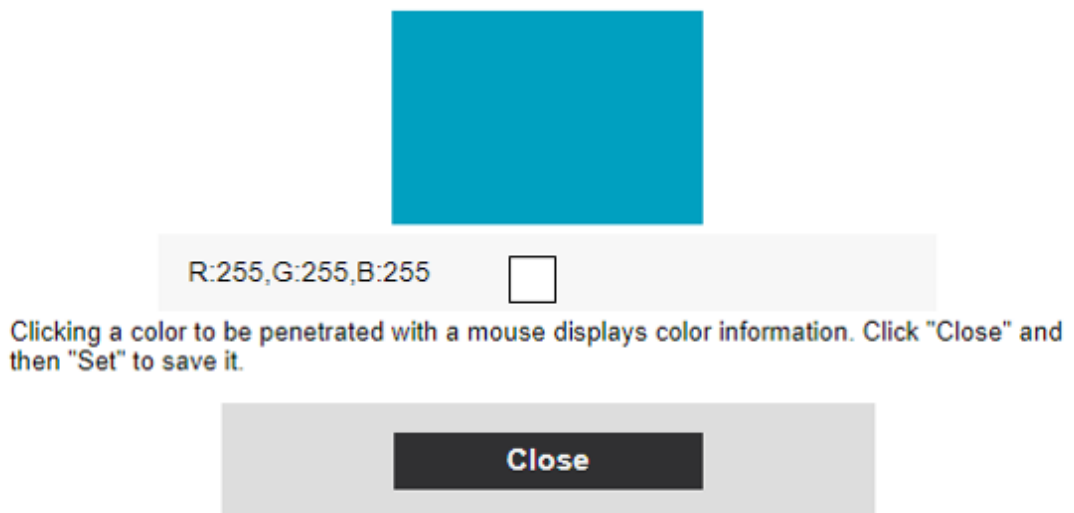

- 2 Click the color you want to transparent in the displayed image. The selected color and RGB are displayed.
- 3 Close the subwindow by clicking [Close].
- 4 Finally, clicking the [Set] button will make the selected colors transparent.

8 Configuring Advanced Image and Audio Settings [Video/Audio]

On the Video/Audio page, you can make settings for JPEG images, H.265 images, and H.264 images, as well as settings for image quality and sound.

The Video/Audio page consists of the [Image] tab, [Quality] tab, and [Audio] tab.

8.1 Setting the imaging mode [Video]

On the Picture page, select [Image]. Refer to the User's Manual for details on how to display and operate the advanced settings menu.

[Image Capture Mode]

Selects an image to be displayed on a live image.

Model	Image capture mode
Security Radar (Radar/Camera Image capture size :2MP)	16:9 mode (30fps mode) 16:9 mode (25fps mode)

8.2 Setting JPEG images [Video]

On the Video/Audio page, select [Image]. For details on how to display and operate the advanced settings menu, refer to the User's Manual.

Live Image (Default)

Here, you can make the default settings to be displayed on the live image.

[Initial display stream]

Select the images you want to view in Live image pages:

[2-screen display stream(2)]/ [2-screen display JPEG]/ [Radar Stream (1)]/[Radar Stream (2)]/[Radar JPEG]/[Camera Stream (1)]/[Camera Stream (2)]/[Camera JPEG]



[Notice]

- Select [2-screen display stream (2)] and [2-screen display JPEG] to select the layout of the two screens in the live image.
 [Left/right placement]/[Up/down placement]
- After selecting the JPEG, you can select the refresh rate.
 MJPEG/ [Refresh interval : 1s]/[Refresh interval : 3s]/[Refresh interval : 5s]/[Refresh interval : 10s]/[Refresh interval : 30s]/[Refresh interval : 60s]
- Streams can be selected when [Stream transmission] is [On].

JPEG

Here, you set the [Image Capture Size] [Quality] [Refresh interval (JPEG) *] of the JPEG. For settings related to H.265 (or H.264) images, refer to the User Manual.

[Image Capture Size]

When viewing JPEG images, select the Image capture size of the image you want to view.

Security Radar

Model	Image capture mode	JPEG
Security Radar (radar/camera)	16:9 mode (30fps mode)	1920x1080
	16:9 mode (25fps mode)	1280x720
		640x360
		320x180

[Quality]

Sets the quality of the JPEG images for each Image capture size.

[0 Super fine]/[1 Fine]/2/ 3/ 4/ [5 Normal]/6/ 7/ 8/ [9 Low]

[JPEG Image-Update Rate (Movie)*]

Select the rate at which the JPEG images are updated.

The [Image Capture Mode] is [Single source [4:3](30fps mode)]:

0.1fps / 0.2fps / 0.33fps / 0.5fps / 1fps / 2fps / 3fps / 5fps / 6fps / 10fps / 12fps / 15fps / 30fps

The [Image Capture Mode] is [Single source [4:3](25fps mode)]:

0.08fps / 0.17fps / 0.28fps / 0.42fps / 1fps / 2.1fps / 3.1fps / 4.2fps / 5fps / 8.3fps / 12.5fps / 25fps



[Important]

[Image Update Rate (Movie)*] of the radar is 30fps and the update rate of 25fps is as follows.

0.1fps / 0.2fps / 0.33fps / 1fps / 2fps / 3fps / 5fps



[Notice]

- If you set [Stream transmission] to [On] and set a value with [*], the image-updating speed may be slower than the set value.
- [*] is omitted in the list of options.
- Depending on the network-environment, Image capture size, image quality, number of simultaneous accesses, etc., the image-updating speed may be slower than the set value.
- If the image is not delivered at the set image-updating rate, you can reduce the Image capture size or image quality to bring it closer to the set value.
- Allows you to select how fast the selected Image capture mode will be updated.

8.3 Configuring Stream Settings [Video]

On the Video/Audio page, select [Image]. Refer to the User's Manual for details on how to display and operate the advanced settings menu.

Here, you can set the [bitrate per client*], [Image Capture Size], and [Quality] of H.265 (or H.264) images.

For settings related to JPEG images, refer to the following.

→ [8.2 Setting JPEG images \[Video\]](#)

Streams

Streaming is a mechanism for simultaneously delivering images with differing Image capture size and frame rates.

The number of streams that can be simultaneously delivered is shown as the number of streams.

[Stream transmission]

Set whether to deliver H.265 (or H.264) images in [On]/[Off].

[On]: Deliver H.265 (or H.264) images.

[Off]: H.265 (or H.264) images are not delivered.



[Notice]

- If you set the [Stream transmission] of every stream to [On], you can view both H.265 (or H.264) and JPEG images in Live image pages.
- If one of the [Stream transmission] of every stream is set to [On], the image-refresh rate of JPEG images is limited.

For information on how fast JPEG images are updated when [Stream transmission]

is set to [On], see:

→[3.2 Viewing Images from a PC](#)

[Compression]

Select the compression method for the stream to be delivered.

H.265:Distribute H.265 images.

H.264:Distribute H.264 images.

[Image Capture Size]

Select the Image capture size of the H.265 (or H.264) picture:

Security Radar

Model	Image capture mode	H.265/H.264	
		Stream 1	Stream 2
Security Radar (radar/camera)	16:9 mode (30fps mode)	1920x1080	
	16:9 mode (25fps mode)	1280x720	
		640x360	640x360
		320x180	320x180

[Transmission priority]

Set the stream delivery mode from the following:

- [Constant bit rate]:**Delivers H.265 (or H.264) images at the bitrate set in [Max bit rate (per client) *].
- [VBR]:**Delivers H.265 (or H.264) images at the frame rate set in [Frame rate*] while maintaining the image quality level set in [Quality].

At this time, the bit rate is distributed with a variable value within the maximum bit rate set in [Max bit rate (per client) *]. The recording capacity varies depending on the [Quality] setting and the object status.

- [Frame rate]:** Delivers H.265 (or H.264) images at the frame rate set in [Frame rate*].
- [Best effort]:** Depending on the bandwidth of your network, you can distribute H.265 (or H.264) images at varying bit rates, up to the maximum bit rate set in [Max bit rate (per client) *].



[Notice]

- If you set [Transmission priority] to [Frame rate], you might have fewer users available to connect.

[Frame rate*]

Set the frame rate from the following.

-If Image capture mode is [16:9 mode(30fps mode)]:

1fps / 3fps / 5fps / 7.5fps / 10fps / 12fps / 15fps / 20fps / 30fps

-If Image capture mode is [16:9 mode(25fps mode)]:

1fps / 3.1fps / 4.2fps / 6.25fps / 8.3fps / 12.5fps / 20fps / 25fps



[Important]

In both 30fps mode and 25fps mode, the [Frame rate*] of the radar is updated at the following rate.

1fps / 3fps / 5fps



[Notice]

•The [Frame rate*] is limited to [Max bit rate (per client) *]. If a value with [*] is set, the frame rate may be lower than the set value.

If [Transmission priority] is set to [VBR], the video may pause periodically depending on the [Max bit rate (per client) *] and [Quality] settings. Confirm the video after setting.

•[*] is omitted in the list of options.

•You can select a frame rate up to the selected Image capture mode.

•The frame rate may be lower than the set value depending on the number of concurrently connected users or the combination of functions used. Confirm the video after setting.

•When the frame rate is set to a low value, images may not be displayed correctly depending on the web browser used.

[Max bit rate (per client) *]

1 Select the H.265 (or H.264) bitrate for the client:

64kbps / 128kbps * / 256kbps * / 384kbps * / 512kbps * / 768kbps * / 1024kbps * / 1536kbps * / 2048kbps * / 3072kbps * / 4096kbps * / 6144kbps * / 8192kbps * / 10240kbps * / 12288kbps * / 14336kbps * / 16384kbps * / 20480kbps * / 24576kbps * / ---Free entry---

When [--Free Input--] is selected, the bit rate can be input freely within the settable range.

When [Transmission priority] is [Constant bit rate], [Frame rate], or [Best effort]

For 320x180,640x360:64kbps~4096kbps *

1280x720*¹For:128kbps*~8192kbps *

1920x1080*¹For: 256kbps*~12288kbps *

When [Transmission priority] is [VBR]

For 320x180, 640x360: 64kbps~12288kbps *

1280x720*1For:128kbps*~12288kbps *

1920x1080*1For:256kbps*~24576kbps *



[Notice]

•The bitrate of the stream is limited to the [Bandwidth control(bit rate)] on the [Network] tab of the Network page. Therefore, if a value with [*] is set, video may not be delivered.

→ Refer to the user manual.

•We recommend the following 8192kbps settings for the bitrate of the stream. If a value larger than the 8192kbps is set, the continuity of recorded video may be abnormal.

•If the refresh rate is short, the set bitrate may be exceeded depending on the object.

•Depending on the number of concurrent users or the combination of functions used, the bit rate may be lower than the set value. Confirm the video after setting.

[Quality]

Select the quality of the H.265 (or H.264) images:

For [Constant bit rate], [Frame rate], and [Best effort]:Motion Priority/Standard/Image Quality Priority

For [VBR]: [0 Maximum image quality]/ [1 Fine]/2/3/4/[5 Normal]/6/7/8/[9 Low]

[Smart Coding] – [GOP control]

You can use GOP control to reduce the volume of data.

When [H.265] is selected in [Compression]: [Off]/ [Low (variable GOP 1s-8s)/ [Mid (variable GOP 4s-16s)]/ [Advanced(Fixed GOP 60s w/1s key-frame)]/[Frame rate control (variable GOP4s-16s + framerate control)]

When [H.264] is selected in [Compression]: [Off]/ [Low (variable GOP 1s-8s)/Mid (variable GOP 4s-16s)

[Smart Coding] –[Auto VIQS]

Auto VIQS lets you detect movement in an image and compress images in a non-motion area.

[On]:Use the automatic VIQS function.

[OFF]:The automatic VIQS function is not used.



[Important]

- The [Smart Coding] settings are for the camera-side only. It is not displayed on the radar side.



[Important]

- If you set [Low (Variable GOP 1s-8s)], [Mid (Variable GOP 4s-16s)] or [Frame rate control (Variable GOP4s-16s+ frame rate control)], you cannot record to the SD memory card.

Also, if you set a Advanced (fixed GOP 60s + 1s keyframe), you can only record to SD in [Manual save] [Schedule].



[Notice]

- Using GOP control increases the time between refreshing H.265 (or H.264) images. Therefore, do not use it when there are many errors in the network environment.

- [Low (Variable GOP 1s-8s)]/[Mid (Variable GOP 4s-16s)]/[Frame rate control (Variable GOP4s-16s + frame rate control)] can be set only when [VBR] is selected in [Transmission priority].

[Advanced (fixed GOP 60s + 1s keyframe)] can be set regardless of the [Transmission priority].

- [Low (Variable GOP 1s-8s)]/[Mid (Variable GOP 4s-16s)]/[Frame rate control (Variable GOP4s-16s + frame rate control)] can reduce the volume of data when there are no detectable objects (Face/Human/Car/Two-wheel) in the image.

[Advanced (fixed GOP 60s + 1s keyframe)] can reduce the volume regardless of the presence of detected objects.

- When [Frame rate control (Variable GOP 4s-16s + frame rate control)] is set, the frame rate can be changed from 1fps to [Frame rate*] according to the presence or absence of the detected object.
- If [Frame rate control (Variable GOP 4s-16s + frame rate control)] is set, the display may temporarily slow down or speed up when the frame rate is switched.

[Refresh interval]

H.265 (or H.264) Selects the interval (i-picture interval: 0.2 to 5 seconds) at which images are refreshed.

If there are many errors in the network environment, setting a shorter refresh interval will reduce image distortion.

However, the image update speed may decrease or the set bit rate may be exceeded.

[0.2s] / [0.25s] / [0.33s] / [0.5s] / [1s] / [2s] / [3s] / [4s] / [5s]



[Notice]

- If [GOP control] is set to [Low (variable GOP 1s-8s)], the refresh rate is set to the highest 8s.
- If [GOP control] is set to [Mid (variable GOP 4s-16s)], the refresh rate is set to the highest 16s.
- If [GOP control] is set to [Advanced (fixed GOP 60s + 1s keyframe)], the refresh rate is set to 60s.
- If [GOP control] is set to [Frame rate control (Variable GOP 4s-16s + frame rate control)], the frame rate will vary between the 1fps and [Frame rate*] settings according to the size of the change in the picture.

The smaller the frame rate, the longer the refresh interval. The refresh rate is at most 16s.

[Transmission type]

Select the delivery method for H.265 (or H.264) images:

[Unicast port (AUTO)]:

When sending images and sound from this unit, [Unicast port1(Image)] and [Unicast port2(Audio)] are set automatically.

We recommend that you set it to [Unicast port (AUTO)] if you do not need to fix the port number that delivers the stream, for example, when using it in a network.

[Unicast port (MANUAL)]:

When sending images and sound from this machine, you need to set [Unicast port1(Image)] and [Unicast port2(Audio)] manually.

→ Refer to the instruction manual.

When accessing the camera using a browser, the port number is automatically selected even if this setting is made. However, when streaming via the Internet, make sure to fix the communication permission port number to be set on the broadband router (hereinafter referred to as "router").

For details, refer to the router's instruction manual.

[Multicast]:

You can access the machine simultaneously without restricting the number of people. If you want to send streams in multicast, enter the [Multicast address], [Multicast port], and [Multicast TTL/HOPLimit].



[Notice]

- For the maximum number of concurrent unicast accesses, refer to the user manual.
- If [Unicast port (MANUAL)] is selected, you must configure unicast port numbers.
- If you configure multicast, you will not be able to view H.265 images (or H.264 images) in the browser.
- If [Multicast] is selected, you must configure multicast IP addressing.

[Unicast port1(Image)]

Enter the unicast port number (used when sending images from this machine).

Configurable port number:1024 to 50000 (Even number can be set)

[Unicast port2(Audio)]

Enter the unicast port number (used when transmitting audio from this unit).

Configurable port number:1024 to 50000 (Even number can be set)

[Multicast address]

Enter the multicast IP addressing.

Images and sounds are sent to the specified IP.

IPv4 setting range :224.0.0.0~239.255.255.255

IPv6 setting range :Multicast address starting from the FF



[Notice]

- Confirm the available multicast IP address before entering the address.

[Multicast port]

Enter the multicast port number (used when sending images from this machine).

Configurable port number:1024 to 50000 (Even number can be set)



[Notice]

- When transmitting audio from this machine, the port number obtained by adding [1000] to the multicast port number is used.

[Multicast TTL/HOPLimit]

Enter the TTL/HOPLimit for the multicast.

Assignable value :1~254



[Important]

- When streams are delivered via the Internet, the delivery image may not be displayed depending on the settings of the proxy server or firewall. In this case, contact your network administrator.
- Disable LAN cards that are not used for reception when displaying multicast images using a PC that contains more than one LAN card.

8.4 Setting the image quality [Quality]

On the Video/Audio page, select [Quality]. Refer to the User's Manual for details on how to display and operate the advanced settings menu.

To [Advanced Settings] for each item>>Clicking this button displays the detailed setting screen in a separate window, allowing you to make settings while viewing the images displayed in the [Quality] tab.?

Here you can set the image quality, digital zoom, privacy zone, VIQS, lens distortion compensation, and installation angle error detection.



[Image adjust]

[Detailed Settings>>]Clicking the button displays the setting screen for image quality in a separate window.

→[8.4.1 Adjusting Image Quality \(Quality Adjustment Screen\)](#)

[Digital zoom]

[Detailed Settings>>]Click the button to open the digital zoom setting screen in a separate window.

→[8.4.3 Adjust the digital zoom](#)

[Privacy zone]

[Detailed Settings>>]Click the [Privacy Zone] button to display the Privacy Zone setting screen.

→[8.4.4 Configuring Privacy Zone Settings \(Privacy Zone Settings Screen\)](#)

[VIQS]

[Detailed Settings>>]Clicking the button displays the VIQS setting window.

→[8.4.5 Set the VIQS](#)

[Lens distortion compensation]

[Detailed Settings>>]Click the button to display the setting screen for lens distortion correction in

a separate window.

→8.4.6 [Setting the lens distortion correction](#)

[Installation angle abnormality detection]

[Detailed Settings>>]Click the [Install Angle Error Detection] button to display the setting screen in another window.

→8.4.7 [Setting Angle Error Detection](#)

8.4.1 Adjusting Image Quality (Quality Adjustment Screen)

On the Video/Audio page, in the [Quality] tab. In the [Image adjust], go to [Advanced Settings>>]Click the button.

→8.4 [Setting the image quality \[Quality\]](#)

You can set the image quality in the setting screen displayed in a separate window.

If you change the value, the changes will be reflected in the images displayed on [Quality].

Clicking the [+] mark to the left of each item in the setting screen expands each item so that detailed settings can be made.

Click the [-] mark to the left of each expanded item to return to the screen before the item was expanded.

<Example: Super Dynamic>

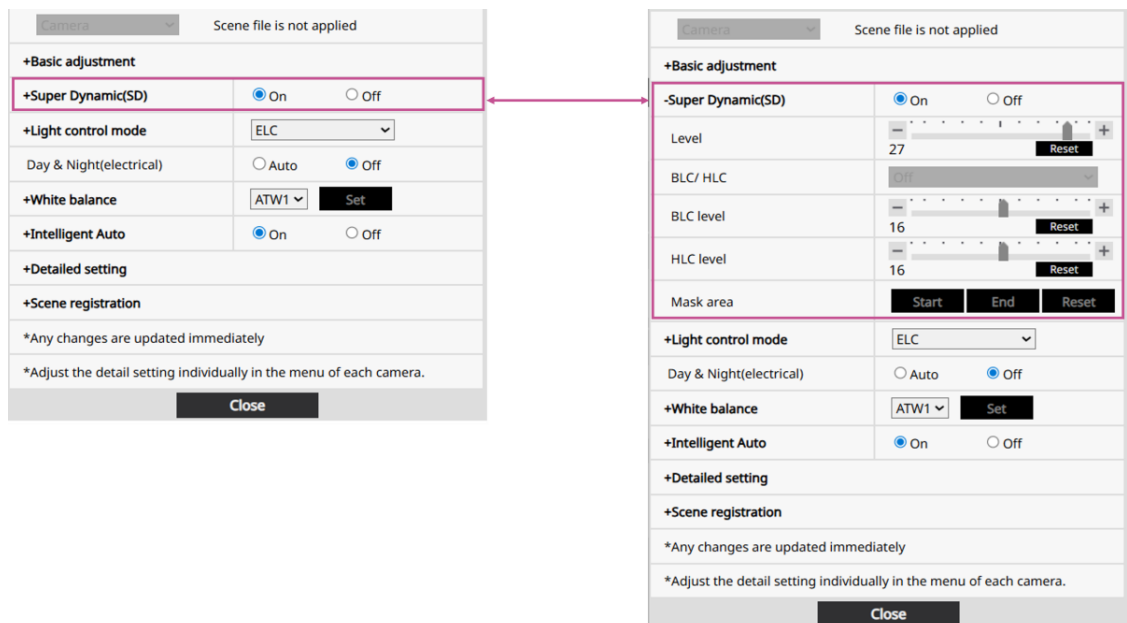

Image quality basic adjustment

[Brightness]

Adjusts the brightness.

Move the slider bar in the [+] direction to brighten the image.

Move the slider bar in the [-] direction to darken the image.

Press [Reset] to return to the default brightness.

[Maximum gain]

Adjusts the maximum gain. When the object becomes darker, the gain is automatically increased to brighten the display.

Increasing the gain may also increase the noise.

Move the slider bar in the [+] direction to increase the maximum gain.

Move the slider bar in the [-] direction to decrease the maximum gain.

Clicking the [Reset] key restores the default settings.

[Chroma gain level]

Adjusts the chroma level (color saturation).

Moving the slider bar in the [+] direction produces a vivid, flashy color.

Move the slider bar in the [-] direction to make the color more stable.

Clicking the [Reset] key restores the default settings.

[Sharpness level]

Adjusts the sharpness level (contour enhancement).

Moving the slider bar in the direction of [+] will result in a sharper image, while moving the slider bar in the direction of [-] will result in a softer image.

Clicking the [Reset] key restores the default settings.

[Digital noise reduction]

The digital noise reduction function automatically reduces noise in low light conditions.

Move the slider bar in the [+] direction to increase the effect of noise reduction. When blur increases

There is.

Move the slider bar in the [-] direction to reduce the noise reduction effect. The blur is reduced.

Clicking the [Reset] key restores the default settings.

Super dynamic

[Super Dynamic]

Use the [On] and [Off] buttons to specify whether the Super Dynamic function should be activated.

For details on Super Dynamic, refer to [Super Dynamic].

[On]: Enables the super dynamic function.

[Off]: Stops the super dynamic function.



[Notice]

- Set [Super Dynamic] to [Off] if the following conditions are observed depending on the lighting conditions.
 - If screen flicker or color change occurs
 - When noise occurs in bright areas on the screen

[Level]

Adjusts the super dynamic level.

Move the slider bar to the [+] position to shoot object with large differences in light and darkness without blurring.

Move the slider-bar to the [-] direction to gradation-rich brightness in the middle of the picture. Clicking the [Reset] key restores the default settings.

What is super dynamic?

If the difference between the light and dark areas is large, the camera will set the aperture of the lens to match the bright area, so the dark area will not be visible. Conversely, if you adjust the aperture of the lens to a dark area, the bright area will not be visible.

Superdynamic is a function that digitally processes an image in which the bright parts of a object with a large contrast are clearly visible and an image in which the dark parts are clearly visible, and faithfully reproduces both the bright and dark parts.

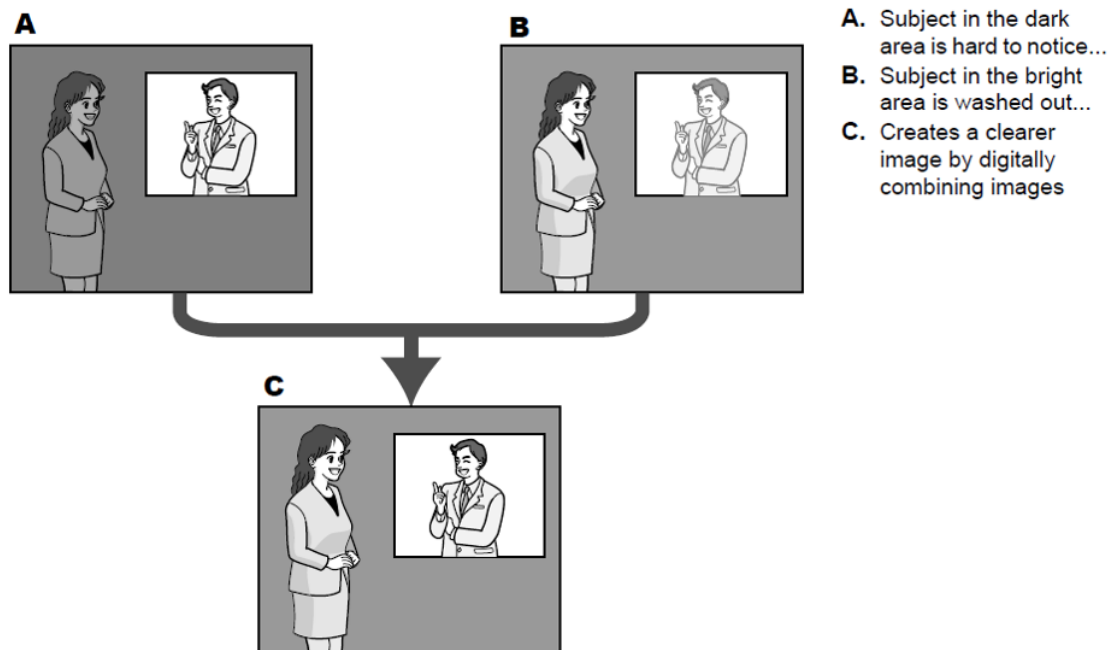

[BLC/ HLC]

Select from the following: This item cannot be set when [Super Dynamic] is set to [On] or

[Intelligent Auto] is set to [On].

[Back light compensation(BLC)]:Enables the backlight compensation function.

[High light compensation(HLC)]:Enables the high light compensation function. The high light compensation function suppresses object overexposure caused by bright lights, such as car headlights, at night.

[Off]: Stops the backlight compensation function and high light compensation function.

[BLC level]

Adjust the backlight compensation level.

Move the slider bar in the [+] direction to increase the effect of backlight compensation. Move the slider bar in the [-] direction to reduce the effect of backlight compensation.

Clicking the [Reset] key restores the default settings.

[HLC level]

Adjusts the high light compensation level.

Move the slider bar to the [+] position to increase the effectiveness of the high light compensation.

Move the slider bar to [-] to reduce the effect of high light compensation.

Clicking the [Reset] key restores the default settings.

[Mask area]

When the mask area is set, the set area can be masked and the light intensity can be adjusted.

This cannot be set when [Super Dynamic] is set to [On].

For details on how to set the mask area, refer to the following.

→[8.4.2 Set the mask area](#)

Light intensity control mode

[Light control mode]

Select the mode for light intensity control from the following.

[Flickless (50 Hz)]/[Flickless (60 Hz)]:This function automatically corrects flicker caused by the flickering light. The 50 Hz/60 Hz should be used depending on the region.

[ELC]: The electronic shutter is used to control the light intensity.



[Notice]

- Raising the shutter speed ($\sim 1/10000$) will reduce blurring even with fast-moving object.
- The higher the shutter speed, the lower the sensitivity.
- Flicker may be reduced by switching the [Image Capture Mode] as follows:
 - 60 Hz Power Frequency Region: Switch [Image Capture Mode] to 30fps mode.
 - 50 Hz Power Frequency Region: Switch [Image Capture Mode] to 25fps mode.



[Important]

- If [Maximum shutter] is set to any of the following settings, the frame rate may decrease if the object is dark.
 - When [Image Capture Mode] is in 30fps:
[Maximum 1/30s] Value of longer duration ([Max 2/30s]/[Max 4/30s]/[Max 6/30s]/[Max 10/30s]/[Max 16/30s])
 - When [Image Capture Mode] is in 25fps:
Value for time longer than [Maximum 1/25s] ([Maximum 2/25s]/ [Maximum 4/25s]/ [Maximum 6/25s]/ [Maximum 10/25s]/ [Maximum 16/25s])



[Notice]

- When [Super Dynamic] is set to [On], [MAX 1/2000s] [MAX 1/4000s] [MAX 1/10000s] in [Maximum shutter] cannot be set.
- If [Maximum gain] is set to [0], the [Maximum shutter] setting is limited as follows:
 - If [Image Capture Mode] is set to [Single source [4:3](30fps mode)]:
You cannot set more than [Max 2/30s].
 - If [Image Capture Mode] is set to [Single source [4:3](25fps mode)]:
You cannot set more than [Max 2/25s].
- If [Light control mode] is set to [Flickerless (60 Hz)], the duration shorter than [Max. 1/120s] cannot be set.
- If [Light control mode] is set to [Flickerless (50 Hz)], the duration shorter than [Max. 1/100s] cannot be set.

[Light control speed]

Adjusts the speed of light intensity adjustment.

Move the slider bar in the [+] direction to increase the speed of the light adjustment.

Move the slider bar in the [-] direction to slow down the adjustment speed.

Clicking the [Reset] key restores the default settings.

Simple black-and-white switching

[Day & Night(electrical)]

Choose how to switch between black and white and color images:

[Auto]: Switches to black and white images when the ambient brightness (illumination) is less than or equal to approximately 1.0 lx. Note that it takes some time for the image to change.

[Off]: Use this mode when you want to capture color images even at night.



[Notice]

- Switching to a color image is approximately 5 to 8 times as bright as the above. It may change depending on the environment.
- When [Maximum gain] is set to low, it may be difficult to change depending on the circumstances.

White balance

[White balance]

Choose how you want to adjust the white balance:

Use the R (red) or B (blue) volume to adjust the white tint.

[ATW1]: Set to automatic color temperature tracking mode. The camera continually checks the color temperature of the light source and adjusts white balance automatically. Operating area is approx. 2700 K~6000 K.

[ATW2]: Set to automatic color temperature tracking mode under sodium lighting. The camera automatically adjusts the white balance under sodium lighting. Operating area is approx. 2000 K~6000 K.

[AWC]: Set to automatic white balance control mode. Because the light source is fixed, this mode is suitable for shooting where the light source does not change. Operating area is approx. 2000 K~10000 K.



[Notice]

- If the following conditions are met, colors may not be reproduced faithfully. If this happens, set it to [AWC].
 - Most dark object
 - Through blue sky and dusk sun
 - Object with too low illumination
- If you select [AWC], press [Set].

[Red gain]

Adjusts the red color of the image.

Move the slider bar in the [+] direction to darken the red color. Move the slider bar in the [-] direction to make the red color light. Clicking the [Reset] key restores the default settings.

[Blue gain]

Adjusts the blue color of the image.

Move the slider bar in the [+] direction to darken the blue color. If you move the slider bar in the [-] direction, the blue color becomes light. Clicking the [Reset] key restores the default settings.

[Mask area]

When you set the mask area, you can mask the set area and adjust the white balance.

For details on how to set the mask area, refer to the following.

→[8.4.2 Set the mask area](#)

[Adjustment speed]

Adjusts the white balance adjustment speed.

Move the slider bar in the [+] direction to increase the white balance adjustment speed. Moving the slider bar in the [-] direction slows down the white balance adjustment speed. Clicking the [Reset] key restores the default settings.

Intelligent Auto

[Intelligent Auto]

Set whether to activate the intelligent auto function with the On/Off.

Intelligent Auto is a function that identifies scenes (backlighting, outdoors, night scenes, etc.), people's face, moving object, etc., and makes it easier to see people's faces and moving object by automatically adjusting the aperture, gain, shutter speed, and contrast.

What is Intelligent Auto?

This function determines scenes (backlight, outdoor, nightscape, etc.), faces of people, moving object, etc., and makes it easier for the camera to see faces and moving object by automatically adjusting the aperture, gain, shutter speed, and contrast.

[Motion priority level (Shutter)]

Adjusts the movement priority level when using Intelligent Auto.

Moving the slider bar to the [+] position prevents blurring of the moving object, but increases the noise of the dark object.

Moving the slider bar toward [-] will blur the moving object, but will reduce dark object artifacts.

Clicking the [Reset] key restores the default settings.



[Notice]

- Flickering caused by fluorescent lights may occur when Intelligent Auto is activated. In this case, make one of the following settings.
 - Adjust the [Motion priority level] slider bar to [-].
 - Change the [Light control mode] to [Indoor scene(50Hz)] or [Indoor scene(60Hz)].

Advanced settings

[Auto contrast adjust]

Set whether to activate the contrast auto adjustment function in [On]/[Off] (manual).

[On]: Activates the automatic contrast adjustment function.

[Off(Manual)]: Stops the automatic contrast adjustment function.



[Notice]

- This item cannot be set when [Intelligent Auto] is set to [On].

[Contrast level]

Adjusts the contrast intensity.

Move the slider bar in the [+] direction to increase the contrast of the image.

Move the slider bar in the [-] direction to decrease the image contrast.

Clicking the [Reset] key restores the default settings.



[Notice]

- This item cannot be set when [Fog compensation] is set to [On].

[Adaptive black stretch]

Adjusts the brightness of dark areas of the image.

Move the slider bar in the [+] direction to brighten the darker areas of the image.

Move the slider bar in the [-] direction to darken the dark part of the image.

Clicking the [Reset] key restores the default settings.



[Important]

- The [Adaptive black stretch] setting may cause darker areas to become more noisy, and darker and lighter areas may appear darker or brighter than other darker or lighter areas.



[Notice]

- This item cannot be set when [Fog compensation] is set to [On].

[Adaptive highlight stretch]

Adjusts the brightness of the bright parts of the image.

Moving the slider bar in the [+] direction increases the difference between light and dark areas in the image.

Move the slider bar in the [-] direction to decrease the difference between light and light in the image.

Clicking the [Reset] key restores the default settings.



[Notice]

- This item cannot be set when [Fog compensation] is set to [On].

[Fog compensation]

Use the On/Off to set whether to enable the fog compensation function.

It cannot be set when [Intelligent Auto] is set to [On] or [Auto contrast adjust] is set to [On].

Using the fog correction function, the image can be easily corrected by digital image processing when the image is blurred, such as when fog occurs.

On: Enables the fog compensation function.

Off: Stops the fog correction function.



[Notice]

- When [Fog compensation] is set to [On], [Contrast level], [Adaptive black stretch], and [Adaptive highlight stretch] cannot be set.

[Level]

Adjusts the fog compensation level.

Moving the slider bar in the [+] direction increases the correction level, while moving the slider bar in the [-] direction decreases the correction level. Clicking the [Reset] key restores the default settings.

[Pedestal Level]

Move the slider bar to adjust the black level of the image.

Move the slider bar in the [+] direction to brighten the image. Move the slider bar in the [-] direction to darken the image. Clicking the [Reset] key restores the default settings.

Scene registration

[Scene file]

The combination of the adjusted setting items can be saved as a scene file. Select the scene file here.

You can set the registered scene file on the schedule page. When the recording environment changes greatly depending on the time, you can record images using a combination of setting items according to the environment by registering in the schedule.

→[6.1.1 Setting Schedule/Alarm \(Event Type Setting Screen\)](#)

[Scene file title]

You can change the scene filename (up to 10 characters) displayed in [Scene file]. [1:], [2:], [3:], You can only change the file name displayed in [4:].

Characters that cannot be entered:Half-pitch symbols " & ¥

[Load] key

Loads the settings selected in [Scene file] and applies them to the currently selected images.

[Activate Account] key

Registers the set of the currently displayed image quality adjustment items to the scene file displayed on the [Scene file].

8.4.2 Set the mask area

This section explains how to adjust the light intensity by masking a part of the screen.

To set the mask area, set [Super Dynamic] to [Off].

- 1 Displays the image quality adjustment setting screen.

→ [8.4 Setting the image quality \[Quality\]](#)

Camera		Scene file is not applied	
+Basic adjustment			
+Super Dynamic(SD)	<input type="radio"/> On	<input checked="" type="radio"/> Off	
+Light control mode	ELC		
Day & Night(electrical)	<input checked="" type="radio"/> Auto	<input type="radio"/> Off	
+White balance	ATW1	Set	
+Intelligent Auto	<input type="radio"/> On	<input checked="" type="radio"/> Off	
+Detailed setting			
+Scene registration			
*Any changes are updated immediately			
*Adjust the detail setting individually in the menu of each camera.			
Close			

- 2 Click the + to the left of the [Super Dynamic] to display the Super Dynamic Advanced menu.

-Super Dynamic(SD)	<input type="radio"/> On <input checked="" type="radio"/> Off
Level	<div style="display: flex; align-items: center;"> - <div style="flex-grow: 1; border: 1px solid #ccc; position: relative;"> <div style="position: absolute; top: -5px; left: 50%; transform: translate(-50%, -50%);"> </div> </div> + </div> <div style="display: flex; justify-content: space-between; margin-top: 5px;"> 27 Reset </div>
BLC/ HLC	Off ▼
BLC level	<div style="display: flex; align-items: center;"> - <div style="flex-grow: 1; border: 1px solid #ccc; position: relative;"> <div style="position: absolute; top: -5px; left: 50%; transform: translate(-50%, -50%);"> </div> </div> + </div> <div style="display: flex; justify-content: space-between; margin-top: 5px;"> 16 Reset </div>
HLC level	<div style="display: flex; align-items: center;"> - <div style="flex-grow: 1; border: 1px solid #ccc; position: relative;"> <div style="position: absolute; top: -5px; left: 50%; transform: translate(-50%, -50%);"> </div> </div> + </div> <div style="display: flex; justify-content: space-between; margin-top: 5px;"> 16 Reset </div>
Mask area	<div style="display: flex; justify-content: space-around; width: 100%;"> Start End Reset </div>

- 3 Clicking [Mask area]'s [Start] button. A border will be displayed, and the images displayed on the [Image Quality] tab will be divided into 48 (8 x 6) images.

Image
Image quality
Audio

Camera ▼

Image adjust	Setup >>
Digital zoom	Setup >>
Privacy zone	Setup >>
VIQS	Setup >>
Lens distortion compensation	Setup >>
Installation angle abnormality detection	Setup >>

- 4 When you click the division area to be masked, the frame you clicked is set to the mask area and turns white. To unmask, click the mask area again.

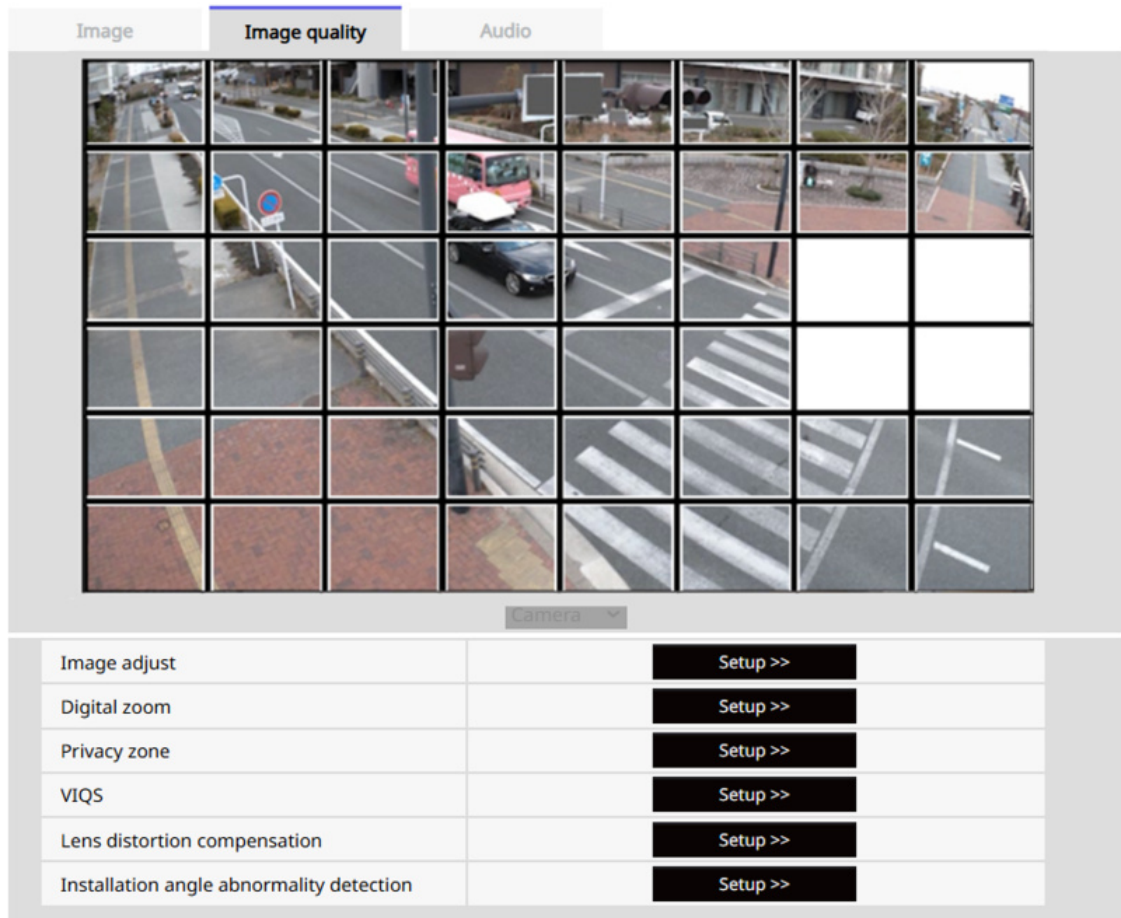

- 5 After setting the mask area, clicking the [End] button. The frame disappears from the top of the picture on the [Quality] tab.



[Notice]

- If you want to clear all the mask areas that have been set, press [Reset].

8.4.3 Adjust the digital zoom

In the [Quality] section of the Picture Page, in [Digital zoom], [Advanced Settings]>>Click the] button.

→8.4 [Setting the image quality \[Quality\]](#)

Use the digital zoom to adjust the angle of view of the displayed image.

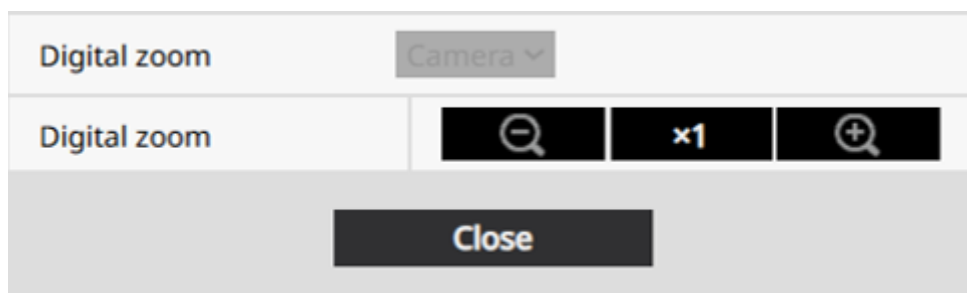

[Digital zoom] button

 :Adjust the zoom (magnification) in the [Telephoto] direction.

 :Zoom (magnification) can be increased by 1.0.

 :Adjust the zoom (magnification) in the [Wide] direction.

[Close] button

Close the digital zoom setting screen.

8.4.4 Configuring Privacy Zone Settings (Privacy Zone Settings Screen)

On the Video/Audio page, in the [Quality] tab. In the [Privacy zone], go to [Advanced Settings>>]

Click the button.

→[8.4 Setting the image quality \[Quality\]](#)

Here, if there is a part of the recording location (image) that you do not want to be displayed, it is set not to be displayed as a privacy zone.



[Area]

It is set as a privacy zone by specifying four vertices on the image. Each zone can also be set to overlap. Zones are set in order from Area 1.



[Notice]

•Set the privacy zone to be wider than the object to be hidden.

[Status]

Set whether to show privacy zones by [Enable]/[Disable].

[Enable]:Displays the privacy zone.

[Disable]:Do not display privacy zone.

[Delete] button

Click the button of the area you want to delete to delete the zone.

[Close] button

Close the Privacy Zone Settings screen.



[Important]

- If you change the [Image Capture Mode] on the [Image] tab after setting the privacy zone, the privacy zone may be offset. Be sure to check the privacy zone settings again.
- If you set the Privacy Zone and then set the Digital Zoom, the Privacy Zone may be offset. Be sure to check the privacy zone settings again.
- If you set the privacy zone when lens distortion correction is enabled, it may shift. If this happens, return the lens distortion correction to [0] once, set the privacy zone, and then set the lens distortion correction again.

8.4.5 Set the VIQS

In the [Quality] tab. on the Video/Audio page, in [VIQS], go to [Advanced Settings>>] Click the button.

→8.4 [Setting the image quality \[Quality\]](#)

What is VIQS?

Abbreviation of Variable Image Quality on Specified area, which allows you to change the image quality of a specified area.

You can set a high-quality image within the range specified in the recording location (image) to make it easier to view. The image quality outside the specified range is low, and you can reduce the image data size.



[Notice]

- The VIQS applies only to H.265 (or H.264) images.
- Up to 8 VIQS can be set.
- After setting [Stream] to [On], press [Leave] to check the picture after VIQS setting.
You can also use Live image pages to view and view H.265 (or H.264) images.
- The VIQS function cannot be used in the following cases:
 - When [Auto VIQS] of [Stream(1)–Camera] is set to [On]

VIQS Area Setting

8 Configuring Advanced Image and Audio Settings [Video/Audio]
 8.4 Setting the image quality [Quality]

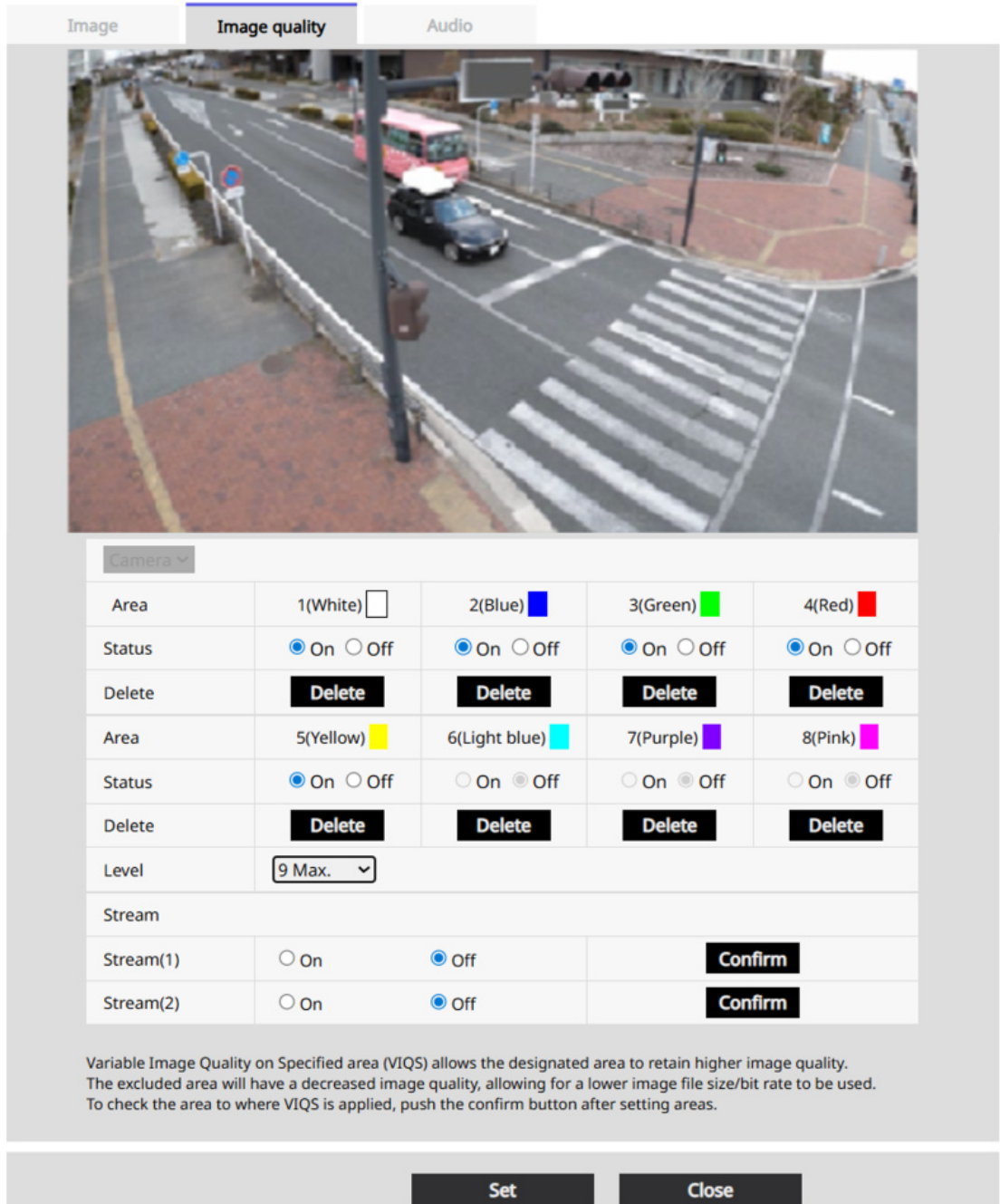

[Area]

Selecting a VIQS area in a picture sets the settings in order from area 1.

[Status]

Set the VIQS in [Enable] or [Disable].

[Enable]:Set the VIQS area.

[Disable]:Does not set the VIQS area.

[Delete] button

Click the button of the area you want to delete to delete the area frame.

[Level]

Sets the level difference between the image quality in the specified range and the image quality outside the specified range. The higher the level difference, the lower the quality of the image outside the specified range and the smaller the image data size.

[0: Minimum], 1, 2, 3, 4, [5: Standard], 6, 7, 8, [9: Maximum]

Stream selection

Select whether to enable the VIQS function for streaming images in [On] or [Off].

The [Leave] button allows you to see the images in the respective streams.



[Notice]

- If the [Stream transmission] of the stream is set to [Off], you cannot select the stream by clicking the [Leave] button.

8.4.6 Setting the lens distortion correction

In the [Quality] tab, on the Video/Audio page, in [Lens distortion compensation], go to [Advanced Settings>>] Click the button.

→8.4 [Setting the image quality \[Quality\]](#)

You can use lens distortion correction to correct distortion.

The correction amount can be adjusted.

The degree of distortion correction depends on the zoom factor. Adjust the image angle with the zoom setting, then set the lens distortion compensation.

[Lens distortion compensation]

Allows you to toggle the lens distortion compensation between [On] and [Off].

Move the slider bar in the [+] or [-] direction to adjust image distortion.

Clicking the [Reset] key restores the default settings.



[Notice]

- If Lens Distortion Correction is turned On, the frame rate may decrease.

8.4.7 Setting Angle Error Detection

[Check setting angle]

Set [View Angle Setting] with [Display].

You can correct the position of the camera while checking the deviation from the position when the installation angle is registered.

◎: This indicates a match.

0: Indicates the position when registering the angle of installation.

|: Indicates the amount of deviation from the position when registering the installation angle.

□: Indicates the threshold value at which an installation angle error is detected.

[Angle of view registration]

Configure the [Execute], and [Delete] settings in the [Angle of view registration].

8.5 Setting sound [Audio]

On the Video/Audio page, select [Audio]. Refer to the User's Manual for details on how to display and operate the advanced settings menu.

Here you can make settings related to audio.



[Notice]

- Images and sound are not synchronized. Therefore, there may be slight discrepancy between the image and sound.
- Sound may be interrupted depending on the network environment.

Voice input

[Mic input volume]

Specifies the volume of audio input to this unit. This setting is reflected to the volume when listening to audio on the PC (earpiece) and the volume at [Audio].

[Mic High]/[Medium]/[Mic Low]: Specifies the volume when a microphone is input to the camera.

[Line High]/[Line Middle]/[Line Low]: Specifies the volume when audio is input to the camera as a line input.

[AGC (audio)]

The earpiece sound is automatically amplified and adjusted to the proper volume. Select the level of amplification from the High/ Middle/ Low.

When set to [High], it is easier to hear quiet sounds, but it may sound noisy.

If you are concerned about the noise, set it to [Middle] or [Low]. This setting is linked with the [Audio] volume level.



[Reference]

[AGC (audio)]

The earpiece sound is automatically amplified and adjusted to the proper volume. Select the level of amplification from the High/ Middle/ Low.

When set to [High], it is easier to hear quiet sounds, but it may sound noisy. If you are concerned about the noise, set it to [Middle] or [Low]. This setting is linked with the [Audio] volume level.

[Max bit rate]

Set the audio compression bit rate.

[G.726]: 16kbps / 32kbps

[G.711]: 64kbps (cannot be changed)

[AAC-LC]: 64kbps / 96kbps / 128kbps

Audio delivery

[Audio transmission mode]

Set the communication mode when transmitting/receiving audio data between this unit and the PC from the following items.

[Off]: Audio data is not sent/received between this unit and the PC.

[Mic input]: The PC receives audio from this unit. You can listen to sound with images on the PC. Images and sound are not synchronized.

[Audio output]: Transmits audio from the PC to this unit. Audio can be played through the speakers connected to this unit.

[Interactive(Half-duplex)]: You can make both incoming and outgoing calls. However, you cannot send/receive audio at the same time.

[Interactive(Full-duplex)]: Both incoming and outgoing calls can be made at the same time.

[Mic input interval (Camera to PC)]

Select the voice interval from the following:

[20ms] / [40ms] / [80ms] / [160ms]



[Notice]

- The lower the reception interval, the shorter the delay time. Increasing the value increases the delay time, but reduces audio breaks. Change the settings according to your network environment.
- When [AAC-LC] is selected for [Audio input encoding format], [Mic input interval (Camera to PC)] cannot be selected.

[Audio output volume (PC to Camera)]

Specifies the volume when audio from the PC is played back from this unit.

[High]/[Medium]/[Low]

[Audio output interval (PC to Camera)]

Select the audio transmission interval from the following:

[160ms]/[320ms]/[640ms]/[1280ms]



[Notice]

- The shorter the transmission interval, the shorter the delay. Increasing the value increases the delay time, but reduces audio breaks.

Change the settings according to your network-environment, the performance of your PC, and the use status of applications other than web browsers.

- When multiple users are accessing this unit, audio may be temporarily interrupted or noise may be output. Increasing the value of the transmission interval can reduce audio interruptions and noise.
- Depending on your network environment and settings, audio may not be output.

[Audio output duration]

Sets the maximum duration of a single call.

[1min]/[2min]/[3min]/[5min]/[10min]/[20min]/[30min]/[1h]



[Notice]

- Sending stops after the set time has elapsed after the transmission starts. Click the Send button if you want to send another call.

[Audio output port (PC to Camera)]

Enter the destination port number (the port number of the camera when sending audio from the PC to this machine).

Configurable port No. : 1024 to 50000 (even number can be set)



[Notice]

- The destination port number entered in the [Audio output port (PC to Camera)] is used only when [Transmission type] is set to [Unicast port (MANUAL)].

If the [Stream transmission] is [Off] or [Transmission type]'s [Unicast port (AUTO)] or [Multicast], you do not need to enter the destination port number.

Live image pages

[Audio input encoding format]

Select the audio compression method from the G.726/G.711/AAC-LC.



[Notice]

- In the web browser, you can only listen to AAC-LC.
- The G.711 can be selected only when [Audio transmission mode] is set to [Mic input].
- The G.726 is applied to the compressed method of voice transmission at all times.

[Audio volume control mode]

Select how you want the Live image pages earpiece keys to operate with the volume cursors.

[Adjust PC speaker]: Change the volume of the open PC of the Live image pages.

[Adjust Mic input]: Change the earpiece volume on the camera.

9 [Radar] to set advanced radar settings

On the Radar page, you can configure settings related to radar settings, PTZ linkage, and radar-related detection.

The Radar page consists of the [Radar Settings] tab, [PTZ Linkage] tab, [Radar detection] tab, and [Tamper Detection] tab.

9.1 [Radar Settings] for setting units

[Unit Settings]

[Unit]: Set the units of semi-circular images that indicate the area of the radar irradiation from [Meters]/[Feet].

9.2 [Radar Settings] for configuring basic radar settings

[Basic settings]

[Radar transmission]

Set the setting of the radar transmission with [On]/[Off].

[On]: Use the radar transmission function.

[Off] : Do not use Radar transmission function.



[Notice]

- Transmits multicast packets with the PTP (Precision Time Protocol (2-second period) protocol regardless of the [On] or [Off] of the [Radar transmission].

[Detection sensitivity]

Sets the radar detection sensitivity.

[Low] / [Middle] / [High]



[Reference]

When the detection sensitivity is set to [High], the detection distance is extended and it is easy to detect even small movements. However, there is a risk of erroneous detection of grass and tree shaking. If you are concerned about false positives, set to [Middle] or [Low].

[Detection filter]

Set the radar detection filter.

[None]/[Prioritize People]/[Prioritize Vehicle]



[Reference]

Select [Prioritize People] to detect a person first, [Prioritize Vehicle] to detect a car, or [None] to detect both a person and a car.

[Fluctuation Filter Strength]

Sets the fluctuation filter of the radar.

[Off]/ [Low]/ [Middle]/ [High]



[Reference]

Selects the detection level of swinging objects (grass, branches of trees, etc.). When [High] is set, it is harder to detect swinging objects, and there is less false positives due to grass or tree jitter. However, it is harder to detect small movements. Also, it takes longer for the radar to detect after the target is moved. Set to [Middle] or [Low] or [Off] if you want to detect small movements, or if you want to shorten the time between when a target is moved and when it is detected.

[Radar Channel]

Set the channel to use the radar.

[ch1]/ [ch2]/ [ch3]/ [ch4]/ [ch5]/ [ch6]



[Reference]

Select the channel to use the radar. When using multiple radars, connect the radar to the same wired network and set a different channel for the nearby radar. If the radars of the same channel are in the vicinity, false positives may occur due to interference between the radars. Also, if the radars are connected to different networks, or if wireless communication is used for the connection, false positives may occur due to interference between the radars even if different channels are set.

9.3 [Radar Settings] for configuring radar-related settings

[Display settings]

[Radar Background Screen Color]

Select [White] or [Gray] as the background color.

[White]: Set the radar background color to [White].

[Gray]: Set the radar background color to [Gray].

[Radar Display Transparency]

Set the transparency of the semi-circular images that indicate the radar area in [Off (no transparency)]~[90%].

[30%]~[90%]: Set the transparency of the semi-circle image representing the range of the radar to [30%] to [90%].

[Show Track History]

Select from [Off (No indication)] to [24h] for the trajectory data display time on the radar screen.

[3s]~[24h]: Set the trajectory view in the radar window to [3s] to [24h].



[Reference]

• When the trajectory data display is set, a blue or green line is displayed depending on the status of the radar detection.

Blue line: Radar detection unknown report

Green line: Radar detection notification

[Show Raw Radar Data]

Set the point cloud data [Display] in the radar window to [On] or [Off].

[On]: Set the point cloud view in the radar window to [On].

[Off]: Set the point cloud view in the radar window to [Off].

[Icon/Text Size]

Set the character size of the radar screen from [Large]/[Medium]/[Small].

[Large]: Set the icon/font size to [Large].

[Medium]: Set the icon/font size to [Medium].

[Small]: Set the icon/font size to [Small].



[Notice]

• If Image capture size of 640 x 360 or less is set on the radar side, icons and characters may be difficult to see.

[Show Object Type]

Set the object type indication with [On]/[Off] of [Display].

[On]: Set the object type indication in the radar display to [On].

[Off]: Set the object type indication in the radar display to [Off].

[Show Movement Speed]

Set the movement rate indication with [On]/[Off] of [Display].

[On]: Sets [On] for displaying the movement speed of the radar display.

[Off]: Sets [Off] for displaying the movement speed of the radar display.

9.4 [PTZ Linkage] for checking the connectivity of registered PTZ

[Registered PTZ Camera]

Press [Check Camera Connection] to check the status of the connected PTZ cameras.



[Notice]

For details on how to link PTZ cameras, refer to the following pages.

→ [Calibration guide](#)

9.5 Setting Up PTZ Camera–Tracking [PTZ Linkage]

[PTZ Camera Tracking]

[Multi–Object Tracking Mode]

Select from [Prioritize First Object]/[Prioritize Last Object]/[Prioritize Key Points]/[Capture All in Order].

[Prioritize First Object]: Priority is given to tracking previously detected objects.

[Prioritize Last Object]: The object detected later is prioritized for tracking.

[Prioritize Key Points]: Prioritize tracking of objects close to important points.

[Capture All in Order]: Images are taken sequentially for detected objects.

[Shooting time]

Sets how long each object is recorded when [Capture All in Order] is selected.

[1s]~[99s]

[Important point display position]

Set the location of the critical point that you want to base on when you select [Prioritize Key Points] in [Multi-Object Tracking Mode].

Set the coordinates of the important point with the upper left as the origin. Key points are indicated by a ✕ symbol.

[X]:[0]~[1919]

Increasing the number moves the icon of the important point to the right.

[Y]:[0]~[1079]

Increasing the number moves the icon of the important point down.



[Notice]

- If you have set the location of the important point, you can move the icon "✕" indicating the important point by dragging.

If you move it by dragging, the setting is reflected immediately.

- Press [Set] to save and reflect the [Multi-Object Tracking Mode], [Shooting time] and [Important point display position] settings.

9.6 [Radar detection] for setting radar detection

Radar detection setting

[Detection Settings]

Clicking [To detection settings] opens [Radar detection settings screen].

9.6.1 Radar detection setting [Radar detection settings screen]

The Security Radar is used to set the area/condition for detecting moving objects.

Select a person, car, or unknown detection object for each detection area. Select one of the detection modes: intrusion detection, delay detection, and line crossing.

Up to 8 detection areas and up to 8 mask areas can be set for each setting.

9 [Radar] to set advanced radar settings
 9.6 [Radar detection] for setting radar detection

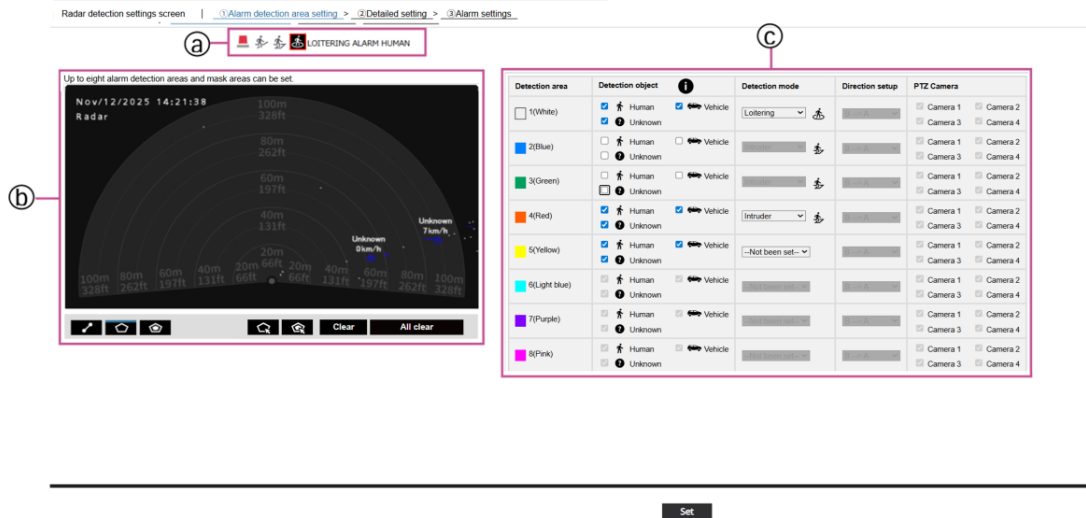

a: Alarm notification area, b: Drawing area, c: Detection condition setting

9.6.1.1 Alarm notification area

When Security Radar detects a moving object, the alarm icon and the icon corresponding to the three detection modes light up. Clicking the alarm icon clears the alarm status and turns off all icons.

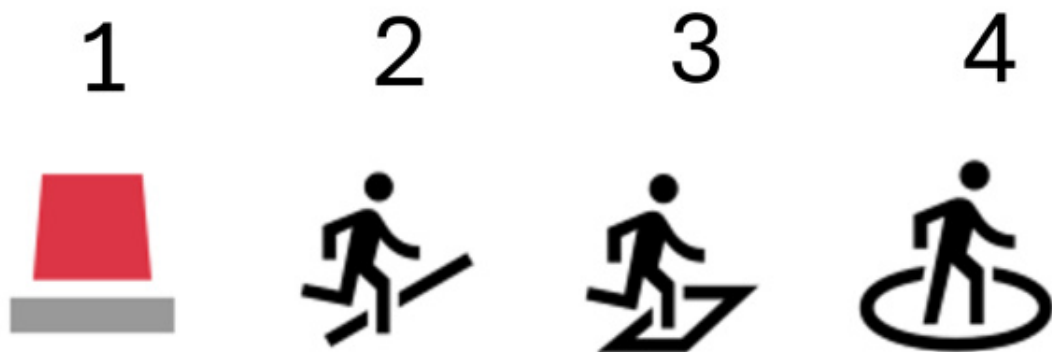

1. Alarm icon
2. Line Cross (CROSS LINE)
3. Intrusion Detection (INTRUDER)
4. Detect delay (LOITERING)

9.6.1.2 Drawing area (Setting the detection area)

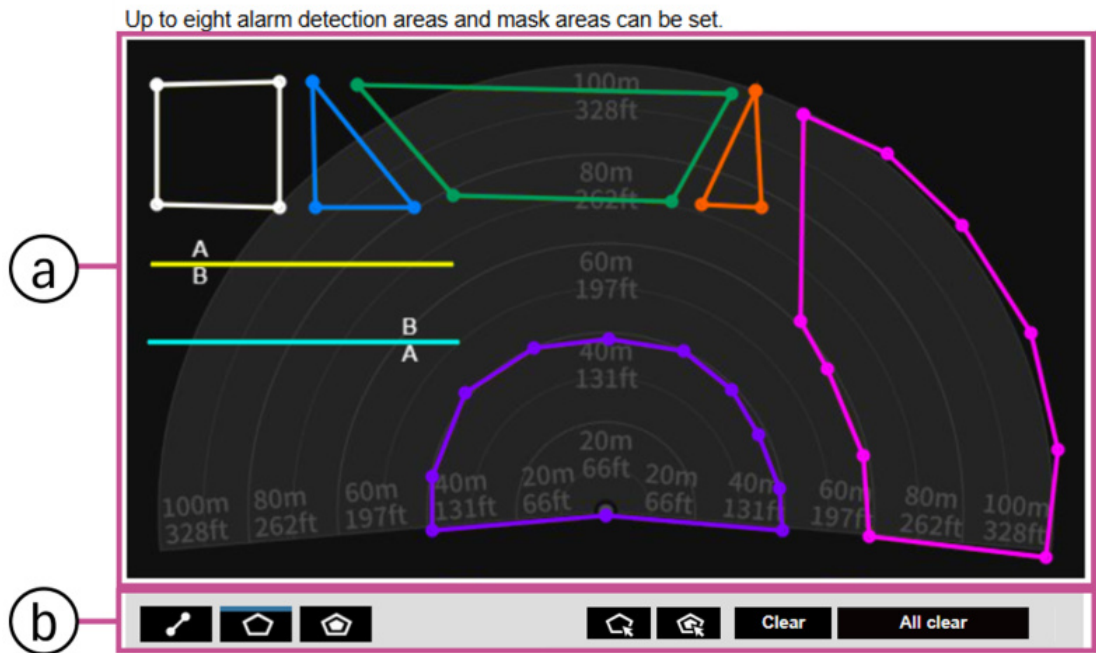

a: Radar image screen, b: Drawing type

[Radar Video Window]

This screen is used to draw the detection area or detection line.

To draw, select the [Detection area(Polygon)] or [Cross line] icon you want to draw from the [Paint type] and drag it to [Camera Image Window].

An alarm occurs when a moving object is determined within the detection area set by drawing.

In addition, an alarm occurs when a moving object crosses the set detection line.

[Paint type]

Click the icon to select a drawing format.



1. Line Cross: Draws a detection line for line crossing.
2. Detection area (polygon): Draws a detection area with a polygon (up to 16).
3. Mask area (polygon): Draws a mask area with a polygon (up to 16).
4. Detection Area (Select): Select the detection area (detection line) you draw.
5. Mask Area (Select): Select the mask area you draw.

6. Erase: Erases the selected detection area (detection line) and mask area.
7. Erase All: Erases all the detection areas (detection lines) and mask areas that have been drawn.



[Notice]

- When the detection area (polygon) and mask area (polygon) are drawn, the area setting is completed by selecting the start point last time.
- The size, length, and shape of the detection area, detection line, and mask area selected in the detection area (selection), and mask area can be changed by dragging the corners of the frame or the end points of the line. You can also move it by dragging the inside or the line of the frame.
- When deleting a detection area or a detection line, and multiple detection areas or detection lines overlap, left-clicking the mouse in the overlapping area switches the selected frame in order.
- You cannot select multiple detection areas, detection lines, and mask areas at the same time.
- By default, the entire drawing area is set as the detection area.

9.6.1.3 Detection condition setting

[Detection Settings]

Use [Detection Settings] to set the detection criteria.

The set conditions can be executed by the schedule setting.

See the following pages for scheduling.

→[6.1.1 Setting Schedule/Alarm \(Event Type Setting Screen\)](#)

[Detection area]

The settings of up to eight detection areas and detection lines are distinguished by the color of the drawing lines.

The stroke colors are set sequentially, starting with [1(White)].

[Detection object]

Check the object (moving object) to be detected for each detection area.

There are three types of objects to be detected:

[Human]/[Vehicle]/[Unknown]

Default setting: [Human], [Vehicle], and [Unknown] are checked



[Notice]

- Three detection objects can also be used in combination.
- If you want to detect all moving objects, check all three.
- All detection objects are initially [Unknown] and will be [Human] and [Vehicle] for some time if the target is a person or car. If you want to send an alert immediately after detecting it, check [Unknown] as well. If you want to reduce false alarms due to grass or trees, uncheck the unnecessary detection objects.
- If you want to prioritize people or cars for detection, you can set it in the [Detection filter settings] of the [Radar Settings].

[Detection mode]

Select the mode to be detected for the specified detection area or detection line.

[Intruder]:Detects that moving objects have entered the detection area.

[Loitering]:Detects that moving objects remain in the detection area for a certain period of time.

[Cross line]:Detects that the moving object exceeds the detection line in the specified direction.

Default: [Intruder]

[Direction setup]

When the detection mode is set to [Cross line], set the direction to detect.

For [Cross line], select from the following three directions:

[A --> B]:Detect when moving from A to B.

[B --> A]:Detect when moving from B to A.

[A <--> B]:Detects when moving from A to B or from B to A.

Initial setting: B --> A direction

[PTZ Camera]

Sets the PTZ that will be shot when radar is detected in the set area/condition.

[Camera 1]/[Camera 2]/[Camera 3]/[Camera 4]



[Notice]

- You can select multiple cameras to shoot when radar is detected.
- For the settings of Camera 1 to Camera 4, refer to the User Manual.



[Notice]

Clicking [Set] saves the settings currently being displayed.

9.6.1.4 Area setting procedure

1. Make sure that the [1.Alarm detection area setting] window is selected.
2. In the drawing area, draw the area you want to detect (hereinafter referred to as detection area).
Draw a location (hereinafter referred to as the mask area) that you do not want to detect within the detection area.
Eight areas can be set for detection area and mask area.
3. Three detection modes are set for each detection area: [Intruder], [Loitering], and [Cross line].
4. If [Detection mode] is [Cross line], set the [Direction setup].
5. Use [PTZ Camera] to set up a linked PTZ to capture the detection target.
6. Click [Set] to save the detection criteria.

9.6.2 Advanced [Radar detection settings screen]

You can configure detailed settings for Radar Detection by clicking [2.Detailed setting] on the [Radar detection settings screen].

Detailed setting		
Radar detection alarm		<input checked="" type="radio"/> Trigger alarm only on first motion detection <input type="radio"/> Trigger alarm on every motion detection
Distance Settings	Movement Speed	1 ~ 65 km/h(1 - 65)
	Distance Threshold	1 m(0 - 99)
Time setting	Intruder detection time	2s ▾
	Loitering detection time	10s ▾
	Cross line detection time	2s ▾
Latitude / longitude sending settings		<input type="radio"/> Enable <input checked="" type="radio"/> Disable
Radar Installation Position	Latitude	0 (-90.0000000 - 90.0000000)
	Longitude	0 (-180.0000000 - 180.0000000)
	Azimuth angle	0 *(0.0 - 359.9)

[\[Detailed setting\]](#)

[Radar Detection Alarm]

Set the conditions for an alarm to be generated when an object is detected within the specified area.

[Trigger alarm only on first motion detection]:An alarm is generated only when it is detected for the first time in the area.

[Trigger alarm on every motion detection]:Triggers an alarm every time it is detected in the area.

[Distance Settings]

Set the movement speed and distance for the object alarm.

[Movement Speed]:Sets the movement speed of the object subject to the alarm.

Minimum speed :[1]km/h

Maximum Speed:[65]km/h

[Distance Threshold]:Set the movement distance of the object to be detected.

[0]~[99]m

[Time setting]

Sets the time from detection to alarm generation.

[Intruder detection time]

Set the time from detecting an intrusion into the area to generating an alarm.

[0.2s] / [0.4s] / [1s] / [2s] / [3s] / [4s] / [5s] / [6s] / [7s] / [7s] / [9s] / [10s]

[Loitering detection time]

Set the time from when stagnation in the area is detected until the alarm is generated.

[10s] / [20s] / [30s] / [1min] / [2min] / [5min] / [10min]

[Cross line detection time]

Sets the time from the detection of crossline passage to the generation of an alarm.

[0.2s] / [0.4s] / [1s] / [2s] / [3s] / [4s] / [5s] / [6s] / [7s] / [7s] / [9s] / [10s]

[Latitude / longitude sending settings]

[Latitude / longitude sending settings]

You can set whether to send latitude and longitude information of objects detected by the radar.

[Enable]: The latitude and longitude information of the object detected by the radar is transmitted.

[Disable]: The latitude and longitude information of the object detected by the radar is not sent.

[Radar Installation Position]

Set the location where the Security Radar is installed.

[Latitude] / [Longitude] / [Azimuth angle]



[Notice]

Latitude and longitude can be entered up to seven decimal places and the direction angle can be entered up to one decimal place.

When the latitude/longitude send setting is enabled, the position of the detected object is automatically calculated based on the Security Radar installation position.



[Notice]

Press [Set] to save and apply the settings.

9.6.3 Link to alarm setting [Radar detection settings screen]

Clicking [3.Alarm settings] on the [Radar detection settings screen] enables you to set the alarm linkage operation when a radar is detected.

Camera action on alarm	
Alarm E-mail notification	E-mail notification setup >>
Alarm image recording(SD memory card)	SD memory card setup >>
TCP alarm notification	TCP alarm notification setup >>
HTTP alarm notification	HTTP alarm notification setup >>
MQTT alarm notifications	MQTT alarm notifications >>

[\[Alarm linkage setting\]](#)

[Alarm E-mail notification]

Clicking [E-mail notification setup >>] takes you to the E-mail setting window when an alarm occurs.

For details on the settings, refer to the User's Manual.

[Alarm image recording(SD memory card)]

Clicking [SD memory card setup >>] moves to the setting window for saving images to the SD memory card when an alarm occurs.

→[10.4.2 Settings related to SD memory card recording when an alarm occurs](#)

[TCP alarm notification]

Clicking [TCP alarm notification setup >>] takes you to the TCP alarm notification notification setting window when an alarm occurs.

→[10.11.1 Setting Up TCP alarm notification Notifications](#)

[HTTP alarm notification]

Clicking [HTTP alarm notification setup >>] takes you to the setting window for HTTP alarm notification when an alarm occurs.

→[10.11.2 Setting HTTP Alarm Notification](#)

[MQTT alarm notifications]

Clicking [MQTT alarm notifications >>] takes you to the setting window for MQTT alarm notification when an alarm occurs.

→[11.2.3 Set the MQTT](#)

9.7 [Radar Settings] for setting radar disturbance detection

Set the radar disturbance detection.

Set the sensitivity and detection time for an alarm when an obstacle is placed in front of the radar eye.

[Tamper Detection]

[REL]-Denial Detection]

Set whether to enable Radar Denial Detection.

[Enable]/[Disable]

[Detection sensitivity]

Sets the detection sensitivity for radar disturbance detection.

[Very Low]/[Low]/[Medium]/[High]

[Detection time]

Sets the time until the radar disturbance detection is activated.

[3s] / [5s] / [10s] / [1min]



[Notice]

- Press [Set] to save and apply the [Tamper Detection] settings.

10 Advanced Alarm Settings [Alarm]

On the Alarm page, you can set alarm operations, alarm images, alarm detection areas, and alarm notification settings using the external I/O terminals.

The Alarm page consists of the [Alarm] tab, [VMD area] tab, [SCD area] tab, [Audio detection] tab, [Impact Detection] tab, and [Transmission] tab.

10.1 [Alarm] for setting alarm operations

On the Alarms page, click the [Alarm] tab. For details on how to display and operate the Advanced menu, refer to the following.

→[4.1.1 How to display](#)

→[4.1.2 How to operate](#)

This section describes the settings related to the operation when an alarm is detected. For the settings related to the alarm image and output terminal, refer to the following.

→[10.4 \[Alarm\] for setting interlocked alarm operation](#)

→[10.2 \[Alarm\] for setting pins](#)

Alarm

[Terminal 1]

Sets the operation of terminal 1.

- [Off]**: Pin functions are not used.
- [Alarm input(TRM1)]**: Accepts terminal alarm input.
- [Close]**: Alarm is detected when the pin status changes to [Close].
- [Open]**: Alarm is detected when the pin status changes to [Open].
- [Close(Continue)]**: Alarm is detected when the pin status changes to [Close]. When the pin status is [Close], the alarm is detected periodically at the alarm non-detection interval.
- [Open(Continue)]**: Alarm is detected when the pin status changes to [Open]. When the pin status is [Open], the alarm is detected periodically at the alarm non-detection interval.
- [Radar]**: Operates as radar alarm input.
- [Cameras]**: Operates as an alarm input for the camera.
- [Radar Self check Start]**: You can check whether the radar is operating normally.
- [Close]**: Radar self-test starts when the pin status changes to [Close].

- **[Open]**: Radar self-test starts when the pin status changes to [Open].
- **[Black & white input]**: Accepts black and white switching input. (Switches to black and white when the entry is [On].)
- **[Auto time adjustment]**: Accepts the time setting by terminal input. If the time difference from the hour (every hour 00 minutes) is within 29 minutes, set to 00 minutes 00 seconds. If the time is less than 5 seconds during SD recording, the time is not changed. When "AUTO TIME ADJUST" is selected, the short-circuit and open selection pull-down menus are displayed.
- **[Close]**: When the pin status changes to [Close], the watch automatically adjusts the time.
- **[Open]**: When the pin status changes to [Open], the watch automatically adjusts the time.



[Reference]

- When terminal 1 is selected as [Self-diagnosis start], the result is output to terminal 3 according to the setting.

[Terminal 2]

Sets the operation of terminal 2.

- **[Off]**: Pin functions are not used.
- **[Alarm input (TRM2)]**: Accepts terminal alarm input.
- **[Short-circuit]**: Alarm is detected when the pin status changes to [Close].
- **[Open]**: Alarm detection is performed when the terminal status changes to [Open].
- **[Short (Continued)]**: Alarm is detected when the pin status changes to [Close]. When the pin status is [Close], the alarm is detected periodically at the alarm non-detection interval.
- **[Open (Continue)]**: Alarm is detected when the pin status changes to [Open]. When the pin status is [Open], the alarm is detected periodically at the alarm non-detection interval.
- **[Radar]**: Operates as radar alarm input.
- **[Cameras]**: Operates as an alarm input for the camera.
- **[Alarm output]**: Alarm is outputted according to the content set in [Output terminal].
- **[Radar]**: Outputs when an alarm is detected by the radar.
- **[Cameras]**: Outputs when an alarm is detected on the camera.

→ [10.2 \[Alarm\] for setting pins](#)

[Terminal 3]

Sets the operation of terminal 3.

- **[Off]**: Pin functions are not used.
- **[Alarm input (TRM3)]**: Accepts terminal alarm input.
- **[Short-circuit]**: Alarm is detected when the pin status changes to [Close].
- **[Open]**: Alarm is detected when the pin status changes to [Open].

- **[Short (Continued)]**: Alarm is detected when the pin status changes to [Close]. When the pin status is [Close], the alarm is detected periodically at the alarm non-detection interval.
- **[Open (Continue)]**: Alarm is detected when the pin status changes to [Open]. When the pin status is [Open], the alarm is detected periodically at the alarm non-detection interval.
- **[Radar]**: Operates as radar alarm input.
- **[Cameras]**: Operates as an alarm input for the camera.
- **[Alarm output]**: Alarm is outputted according to the content set in [Output terminal].
- **[Radar]**: Outputs when an alarm is detected by the radar.
- **[Cameras]**: Outputs when an alarm is detected on the camera.
- **[AUX out]**: Performs AUX export. Displays the [AUX] in the Live image pages.



[Reference]

- [Radar Self check Output] is displayed only when [Radar Self check Start] is selected at terminal 1.
- In [Self-diagnosis result output], if the input from pin 1 is output to pin 3, it is normal. If the input from terminal 1 is not output to terminal 3, an error occurs.



[Notice]

- The AUX is the camera-terminal that the operator can control (Open/Close) from the Live image pages arbitrarily. For example, if you want to control the lighting in the location where the camera is installed, you can control the camera from a remote location by connecting it to a lighting control device.

[VMD alarm]

Clicking [VMD >>] displays the [VMD area] tab of the Alarms page.

→ [10.5 \[VMD area\] to set operation detection](#)

[Scene change detection (SCD) alarm]

Clicking [SCD >>] displays the [SCD area] tab of the Alarms page.

→ [10.8 \[SCD area\] to set the disturbance detection area](#)

[Audio detection alarm]

Clicking [Audio detection >>] displays the [Audio detection] tab of the Alarms page.

→ [10.9 \[Audio detection\] for configuring sound detection settings](#)

[Shock detection alarm]

Click [Impact Detection Settings] to display the [Impact Detection] tab on the Alarm page.

→ [10.10 To set impact detection \[Impact Detection\]](#)

[Command alarm]

Set whether to accept command alarm entry with [On]/[Off].

A command alarm is a function that receives TCP alarm notification notifications from other cameras. When [On] is set, the alarm action can be synchronized with several cameras.

[Reception port]

Set the port number to receive command alarms.

Setting range :1~65535

The following port numbers cannot be set because they are used on this unit.

20、21、22、23、25、42、53、67、68、69、80、110、123、161、162、443、554、995、1883、8883、10669、10670、59000~61000

[Alarm deactivation time]

Set the length of time that the detection operation is not performed after an alarm is detected. For example, if the alarm is set to notify the mobile device or tablet device of the e-mail, this setting can be used to prevent too many e-mails from being sent.

0.5 s、1 ~ 600 s



[Notice]

- Alarm detection time is managed for each alarm type. For example, operation detection and disturbance detection alarms are detected even during the command alarm non-detection time.

[Alarm test]

Clicking [Execute] executes the alarm test function.



[Notice]

- When the alarm test function is executed, this machine detects the command alarm.

It can be used to record SD memory cards triggered by alarm detection and to check notifications to external devices. Use the external device set as the notification destination and the system log of this machine to check related settings.

- The alarm test function cannot be activated more than once within the alarm non-detection time.

10.2 [Alarm] for setting pins

On the Alarms page, click the [Alarm] tab. Refer to the User's Manual for details on how to display and operate the advanced settings menu.

Here, you can make settings related to output terminals.

Output terminal

For the output-pin function, the [Terminal 2] or [Terminal 3] in the [Alarm] settings must be set to [Alarm output].

[Terminal output upon alarm detection]: Sets whether to output alarm signals to the output terminals when an alarm is detected.

[On] / [Off]

[SD memory card error]: Sets whether to output a signal to the output terminal when a warning is detected on the SD memory card.

→ SD Memory Card Alert Detect Condition: SD Memory Card Error (Write Error, Read Error, etc.), 6-Year Runtime, Overwrite Count Exceeded 2000 Times

[On]: When a warning condition is detected, a signal is output to the output terminal, and [Alarm occurrence notification] of the live image is popped over.

[Off]: Stops the detection of a warning condition.



[Important]

- To use this function correctly, format a SD memory card on the Digital Piano before using it.



[Notice]

- Operating hours: 6 years refer to the power-on hours after inserting the SD card into the camera. Overwriting times: 2,000 times is based on the upper limit of the number of rewritable times for professional SD memory cards (MLC types), and the durability is not guaranteed.
- The output terminal and the SD memory card warning use the same output terminal.
- When an alarm or SD memory card warning occurs, the signal is output to the output terminal.
- If a SD memory card warning is detected, [Alarm Notification] pop-over appears in Live image pages. Click the [x] button of [Alarm Notification] to clear the display of [Alarm Notification].
- The output terminal signal output by the SD memory card warning varies depending on the alarm output format setting.
 - When latched: Signaling at the output terminal continues while the cause of the

SD memory card warning continues even after the indication of [Alarm occurrence notification] is cleared.

-For Pulse: Signal output at the output terminal continues while the cause of the SD memory card warning continues even after the display of [Alarm occurrence notification] is cleared. However, signal output at the output terminal stops when the time set in [Alarm output time] has elapsed.

[Terminal state upon alarm detection]

Sets either [Latch] or [Pulse] as the operation of the output pin when an alarm is detected.

[Latch]:When an alarm is detected, the terminal at the time of alarm output is set to [Terminal action upon alarm detection] until the [x] button in [Alarm Notification] is clicked.

[Pulse]:When an alarm is detected, the time set in [Pulse output width] and the pin at the time of alarm output are set in [Terminal action upon alarm detection]. Click the [x] button of [Alarm Notification] to return the output terminal to the normal state.

[Terminal action upon alarm detection]

Use the [Open] and [Close] buttons to set the output status when an alarm is output from the output terminal.

[Open]:Sets the pin to Open when an alarm is generated (usually Close).

[Close]:Sets the pin to Close when an alarm is generated (usually Open).



[Notice]

- When set to [Open], an alarm is issued for approximately 20 seconds when the unit is turned on.

[Pulse output width]

Sets the duration for which an alarm is output from the output terminal when [Pulse] is selected in [Terminal state upon alarm detection].

Setting range :1~120s

10.3 [Alarm] whose AUX name is to be changed

On the Alarms page, click the [Alarm] tab. For details on how to display and operate the advanced settings menu, refer to the User's Manual.

You can rename the [AUX], [Open], and [Close] of the Live image pages.

AUX name

[AUX (Up to 10 characters)]

Enter the name of the [AUX] for the Live image pages.

Characters that cannot be entered:Half-pitch symbols " &

[Open (Up to 5 characters)]

Enter the name of the [Open] in the [AUX] of the Live image pages.

Characters that cannot be entered:Half-pitch symbols " &

[Close (Up to 5 characters)]

Enter the name of the [Close] in the [AUX] of the Live image pages.

Characters that cannot be entered:Half-pitch symbols " &



[Notice]

- The AUX name can be changed when [PIN 3] of the [Alarm] setting is set to [AUX output].
- The AUX is the camera-terminal that the operator can control (Open/Close) from the Live image pages arbitrarily. For example, if you want to control the lighting in the location where the camera is installed, you can control the camera from a remote location by connecting it to a lighting control device.

10.4 [Alarm] for setting interlocked alarm operation

On the Alarms page, click the [Alarm] tab. Refer to the User's Manual for details on how to display and operate the advanced settings menu.

This section describes the settings for functions that operate in conjunction with alarms.

[Alarm E-mail notification]

When [E-mail notification setup >>] is clicked, the setting window related to the e-mail when an alarm occurs is displayed in a separate window.

→[10.4.1 Set Email Sending When an Alarm Occurs](#)

[Alarm image recording(SD memory card)]

Clicking [SD memory card setup >>] displays a separate window for setting the SD memory card recording when an alarm occurs.

→[10.4.2 Settings related to SD memory card recording when an alarm occurs](#)

[TCP alarm notification]

Clicking [TCP alarm notification setup >>] opens a separate window with settings for sending TCP alarm notification notifications when alarms occur.

→[10.4.3 Settings related to TCP alarm notification notification when an alarm occurs](#)

[HTTP alarm notification]

Clicking [HTTP alarm notification setup >>] displays the setting window for sending HTTP alarm notification when an alarm occurs in a separate window.

→[10.4.4 Settings related to HTTP alarm notification when an alarm occurs](#)

[SNMP transmission upon alarm detection]

Clicking [To SNMP setting] displays the setting window for sending SNMP when an alarm occurs in a separate window.

→[10.4.5 Setting for SNMP Send When an Alarm Occurs](#)

10.4.1 Set Email Sending When an Alarm Occurs

On the Alarms page, on the [Alarm] tab. Click [E-mail notification setup >>] in the [Camera action on alarm].

→[10.4 \[Alarm\] for setting interlocked alarm operation](#)

For the setting method, refer to the user manual.

10.4.2 Settings related to SD memory card recording when an alarm occurs

On the Alarms page, on the [Alarm] tab. Click [SD memory card setup >>] in the [Camera action on alarm].

For the setting method, refer to the following.

→[7.2 Setting an SD Memory Card \[SD Memory Card\]](#)

10.4.3 Settings related to TCP alarm notification notification when an alarm occurs

On the Alarms page, on the [Alarm] tab. Click [TCP alarm notification setup >>] in the [Camera action on alarm].

→[10.1 \[Alarm\] for setting alarm operations](#)

For the setting method, refer to the following.

→[10.11.1 Setting Up TCP alarm notification Notifications](#)

10.4.4 Settings related to HTTP alarm notification when an alarm occurs

On the Alarms page, on the [Alarm] tab. Click [HTTP alarm notification setup >>] in the [Camera action on alarm].

→[10.4 \[Alarm\] for setting interlocked alarm operation](#)

For the setting method, refer to the following.

→[10.11.2 Setting HTTP Alarm Notification](#)

10.4.5 Setting for SNMP Send When an Alarm Occurs

On the Alarms page, on the [Alarm] tab. Click [To SNMP setting] in the [Camera action on alarm].

→[10.4 \[Alarm\] for setting interlocked alarm operation](#)

For the setting method, refer to the following.

→[11.2.2 Set the SNMP](#)

10.5 [VMD area] to set operation detection

On the Alarms page, click the [VMD area] tab. For details on how to display and operate the advanced settings menu, refer to the User's Manual.

Here, you can set the area for detecting motion of an object using the Motion Detector function.

When the movement of an object is captured within the specified area, an alarm operation is performed.



[Important]

- [Alarm Notification] is displayed for confirmation when an object movement is detected using the Motion Detector function.

→[3.2.2 About Live image pages](#)

- [Alarm Notification] is also displayed when an alarm input is accepted by the terminal alarm or when a command alarm is accepted.
- Notifications may be delayed depending on the network environment.
- When [Intelligent Auto] is set to [On], an operation detection alarm may be generated due to changes in the brightness of the whole picture depending on the object conditions. In this case, make one of the following settings.
 - Set [Illumination detection suppression] in the operation detection area to [On].
 - Adjust the slider bar of [Detection sensitivity] in the motion detection area to [Low].
- The Motion Detector function is not designed to prevent theft, fire, etc. We assume no responsibility whatsoever for any accident or damage that may occur.



[Notice]

• This function is the function used by the built-in camera.

Set the motion detection area.

Alarm
VMD area
SCD area
Audio detection
Impact detection
Notification



Camera

Area	1(White) 	2(Blue) 	3(Green) 	4(Red)
Status	<input type="radio"/> On <input checked="" type="radio"/> Off	<input type="radio"/> On <input checked="" type="radio"/> Off	<input type="radio"/> On <input checked="" type="radio"/> Off	<input type="radio"/> On <input checked="" type="radio"/> Off
Detection area				
Detection sensitivity	Low High 8	Low High 8	Low High 8	Low High 8
Delete	<input type="button" value="Delete"/>	<input type="button" value="Delete"/>	<input type="button" value="Delete"/>	<input type="button" value="Delete"/>
Light detection control	<input type="radio"/> On <input checked="" type="radio"/> Off			
Area No. notification	TCP alarm notification >>			

* When notifying alarm area numbers by the TCP alarm notification, set "Additional alarm data" to "On".
 * Various functions working with VMD alarm do not work while this page is open. After setting, close this page.

VMD information addition

Information addition On Off

[Area]

If an operation detection area is selected in the image, the settings are made in order from area 1.

[Status]

Set whether to enable or disable motion detection.

[Enable]: Performs motion detection.

[Disable]: Do not perform operation detection.

[Detection area]

Use the slider bar to set the area in the motion detection area that detects the movement of the object. The lower the setting, the smaller the motion of the object. The current setting (1 to 10) is displayed to the right of the slider bar.

[Detection sensitivity]

Use the slider bar to set the sensitivity for detecting movement in the area. Each area can be set individually. The higher the setting, the easier it is to detect the movement.

The current setting (1 (low) to 15 (high)) is displayed below the slider bar.

[Delete] button

Click the button of the area you want to delete to delete the area frame.

[Light detection control]

Use [On]/[Off] to specify whether to prevent motion detection due to changes in lighting brightness, etc.



[Important]

- It may not be possible to suppress the illumination when the brightness and other changes are small.
- If [On] is set to suppress illumination and object with motion is detected, motion detection may not be performed.
- If [Camera title on screen display] is set to [On], the accuracy of motion detection may be reduced.

[Add motion detection information](#)

[Information addition]

Use the On/Off to specify whether or not to send the superimposed image data by adding operation detection information to the image. Operation detection information can be used by some of our network disk recorders search functions. For details of the functions and settings, refer to the instruction manual of the device to be connected.

10.6 [VMD area] to set operation detection area

Set the operation detection area.



[Important]

- All alarms are not detected while changing settings on the setting screen. Close the setting screen after completing the setting.



[Notice]

- This function is the function used by the built-in camera.

Set the motion detection area setting screen



- 1 If you specify an area by dragging over the image, the specified area is set to area [1(White)] and a frame is displayed.
 Areas are set in order from area number 1. The color next to the area number indicates the color of the corresponding frame. Also, the [Status] of the frame you want to set for the area will be [Enable].
- 2 Set the [Detection area] [Detection sensitivity] with the slider bar. For information about

[Detection area] [Detection sensitivity], see the following:

→ [10.7 \[SCD area\] for configuring disturbance detection](#)

The [Detection area] displays the motion detection status for the displayed area and detection sensitivity. Modify the area or [Detection area] [Detection sensitivity] as needed.

- 3 When you have finished configuring the settings, press [Set].



[Important]

- Settings cannot be confirmed unless [Set] is clicked.

- 4 To disable the operation detection area, change the [Status] of the corresponding area to [Disable], and then click the [Set] button. The disabled frame color becomes a dotted line. When disabled, no alarm occurs even if there is a change in the area.
- 5 To delete the operation detection area, click the [Delete] button of the area to delete, and the frame of the deleted area will be deleted.
- 6 Clicking the [Set] button. The settings will be applied to this unit.

10.7 [SCD area] for configuring disturbance detection

This section describes the settings related to the disturbance detection function.

When the interference detection function is used, the alarm is activated when the object changes as the machine is covered with a cloth, lid, etc., or the direction of the machine is changed. One area can be set. When the disturbance is detected within the set area, the alarm is activated.



[Important]

- The disturbance detection function will not work for a while in the following cases:
 - After power-on
 - After changing the disturbance detection setting
 - When the angle of view of this machine changes
- [Alarm Notification] is displayed for confirmation when a disturbance is detected using the disturbance detection function.
→ [3.2.2 About Live image pages](#)
- [Alarm occurrence notification] is also displayed when an alarm input is accepted by the terminal alarm or another alarm such as operation detection alarm occurs.

- Interference detection may not be detected or may be erroneously detected in the following cases:
 - When only a part of the screen is covered, or when the cover is transparent
 - If your object is similar to the one before and after you can change the camera's orientation
 - When Privacy Zone is set
- When the color of the image is close to monochrome, it is difficult to detect the disturbance detection. If disturbance detection is difficult to detect, increase the [Detection sensitivity] setting for the disturbance detection function or increase the area setting for the disturbance detection function.
- If the [Intelligent Auto] is set to [On], an obstruction detection alarm may be generated depending on the object conditions, because the brightness of the whole picture changes. In this case, make one of the following settings.
 - Set the [Detection sensitivity] low.
 - You set a longer [Detection time].
- The disturbance detection function is not designed to prevent theft, fire, etc. We assume no responsibility whatsoever for any accident or damage that may occur.



[Notice]

- This function is the function used by the built-in camera.

Set the disturbance detection area setting screen

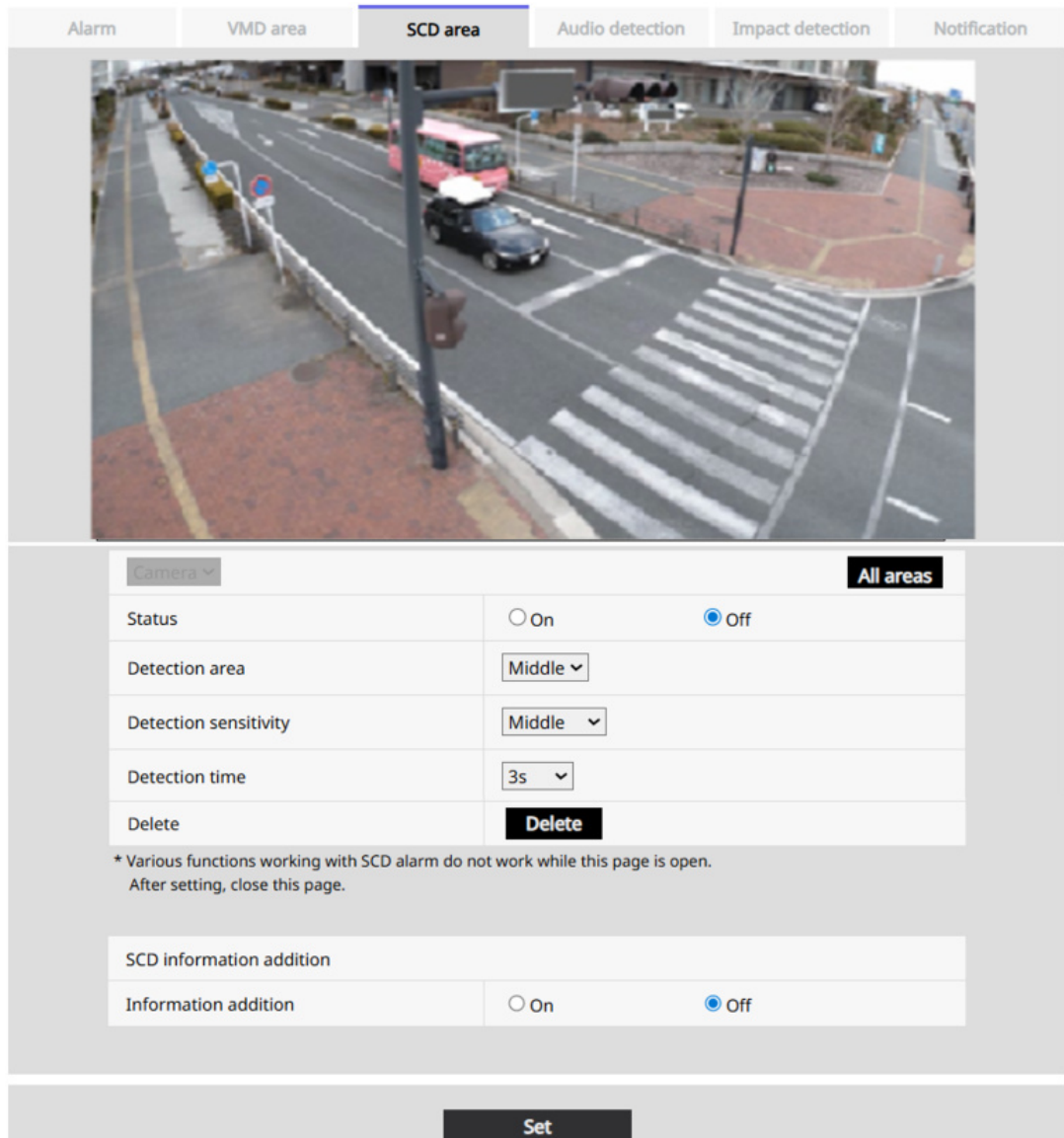

[Area]

Set the disturbance detection area in the image.

[All areas]

Click to set the entire area as the disturbance detection area.

[Status]

Set whether to detect disturbance using [Enable]/[Disable].

[Enable]: Performs disturbance detection.

[Disable]: Denial detection is not performed.

[Detection area]

Set the area in [Small]/[Medium]/[Large] to detect the movement of the object within the disturbance detection area.

[Detection sensitivity]

Select [Very Low]/[Low]/[Medium]/[High] for detecting disturbance within the area.

[Detection time]

Sets how long it takes to activate the disturbance detection alarm after the object changes. If the object changes only continuously within the specified time, the alarm is activated.

[3s] / [5s] / [10s] / [30s] / [1min]

[Delete] button

Click to delete the area frame.

Addition of disturbance detection information

[Information addition]

Use the [On] and [Off] buttons to specify whether or not to send the superimposed image data by adding disturbance detection information to the image.



[Notice]

- The additional disturbance detection information is not used in our network disk recorders (as of November 2025).

10.8 [SCD area] to set the disturbance detection area

- 1 Set the disturbance detection area.



[Important]

- All alarms are not detected while changing settings on the setting screen. Close the setting screen after completing the setting.



[Notice]

- This function is the function used by the built-in camera.

- 2 Clicking [All areas] selects the entire area as the disturbance detection area and displays a frame around the entire screen. Also, [Status] is set to [Enable].

Alarm	VMD area	SCD area	Audio detection	Impact detection	Notification
-------	----------	-----------------	-----------------	------------------	--------------



Camera	All areas
Status	<input checked="" type="radio"/> On <input type="radio"/> Off
Detection area	Middle
Detection sensitivity	Middle
Detection time	3s
Delete	Delete
* Various functions working with SCD alarm do not work while this page is open. After setting, close this page.	
SCD information addition	
Information addition	<input type="radio"/> On <input checked="" type="radio"/> Off

Set

If you drag the mouse over the image and specify an area, the specified area is set to the area (white) and a frame is displayed. Also, [Status] is set to [Enable].

Alarm
VMD area
SCD area
Audio detection
Impact detection
Notification



Camera ▼	All areas
Status	<input checked="" type="radio"/> On <input type="radio"/> Off
Detection area	Middle ▼
Detection sensitivity	Middle ▼
Detection time	3s ▼
Delete	Delete

* Various functions working with SCD alarm do not work while this page is open.
After setting, close this page.

SCD information addition	
Information addition	<input type="radio"/> On <input checked="" type="radio"/> Off

Set

Set the [Detection area] [Detection sensitivity] [Discovery Times]. For details on [Detection area] [Detection sensitivity] [Detect Time], refer to the following.

→ [10.7 \[SCD area\] for configuring disturbance detection](#)

Change the settings of the area or [Detection area] [Detection sensitivity] [Discovery Times] as required.

4 When you are done, press [Set].



[Important]

• Settings cannot be confirmed unless [Set] is clicked.

- 5 If you want to disable the disturbance detection area, change the [Status] to [Disable] and press [Set]. When clicked, the disabled frame color becomes a dotted line. When disabled, no disturbance detection alarms are generated.
- 6 If you want to remove the intrusion detection area, press [Delete]. Click to erase the area frame.



[Notice]

- If you want to reconfigure the disturbance detection area, you must clear the area frame by clicking the [Delete] button.

- 7 Clicking the [Set] button. The settings will be applied to this unit.

10.9 [Audio detection] for configuring sound detection settings

On the Alarms page, click the [Audio detection] tab. For details on how to display and operate the advanced settings menu, refer to the User's Manual.

Here, you can make settings related to sound detection.



[Important]

- When audio is detected using the sound detection function, [Alarm Notification] is displayed to indicate that the audio has been detected.
- [Alarm Notification] is also displayed when an alarm input is accepted by the terminal alarm or when a command alarm is accepted.
- Notifications may be delayed depending on the network environment.
- The sound detection function is not suitable for applications where high reliability is always required (systems designed to prevent this). We assume no responsibility whatsoever for any accident or damage that may occur.

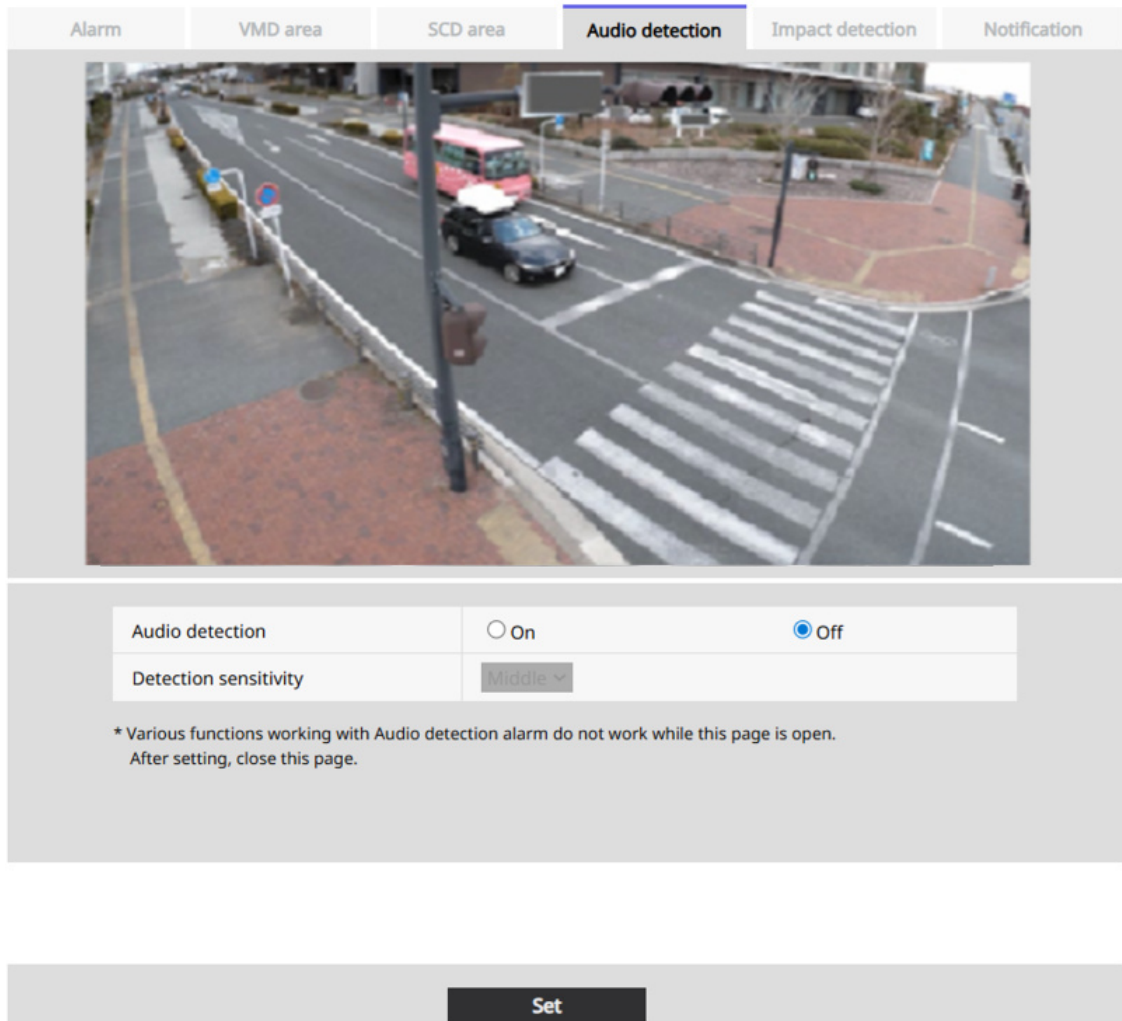

[Audio detection]

Use the On/Off to specify whether to perform tone detection.

[On]: Sound detection is performed.

[Off]: Sound detection is not performed.

[Detection sensitivity]

Select the sensitivity of the detection from the [Low] [Medium] [High].

10.10 To set impact detection [Impact Detection]

Click the [Impact Detection] tab on the Alarm page. For details on how to display and operate the advanced settings menu, refer to the User's Manual.

This section describes how to set up impact detection.



[Important]

- When an impact is detected using the impact detection function, [Alarm occurrence notification] is displayed so that it can be understood that the impact is detected.
- All alarms are not detected while changing settings on the setting screen. Close the setting screen after completing the setting.
- [Alarm Notification] is also displayed when an alarm input is accepted by the terminal alarm or when a command alarm is accepted.
- Notifications may be delayed depending on the network environment.
- The impact detection function is not suitable for applications where high reliability is always required (systems designed for prevention). We assume no responsibility whatsoever for any accident or damage that may occur.

Alarm VMD area SCD area Audio detection **Impact detection** Notification

Impact detection On Off

Detection level Max. value: 156

* Various functions working with Impactdetection alarm do not work while this page is open.
After setting, close this page.
*When an impact is applied to the camera, a blue bar will be displayed to indicate the strength of the impact.The maximum value of the impact received by the camera is displayed in the "Max. value" section.Use this as a guide when setting the "Detection level".The displayed "Max. value" will return to 0 when you press the "Reset" button.

[Impact detection]

Use the On/Off to set whether or not to perform impact detection.

[On]: Performs impact detection.

[Off]: Does not perform impact detection.

[Detection Level]

Use the slider bar to set the threshold at which the impact is detected.

You can adjust the value from 1 to 255. Moving it in the [+] direction will reduce the sensitivity of the impact detection, allowing you to detect only large impacts. [-] If you move it in the direction, the sensitivity to detect an impact becomes strong, and you can also detect a small impact.



[Notice]

- When an impact is applied to the camera while [Impact Detection] is set to [On], a blue bar indicating the impact intensity is displayed. The maximum impact received by the camera is displayed in the [Maximum]. Use this as a guide when setting the [Detection Level]. The displayed [Max.] returns to 0 when [Reset] is pressed.

10.11 [Transmission] for setting the alarm notification

On the Alarms page, click the [Transmission] tab. For details on how to display and operate the advanced settings menu, refer to the User's Manual.

This section describes the settings related to TCP alarm notification notifications and HTTP alarm notifications.

10.11.1 Setting Up TCP alarm notification Notifications

TCP alarm notification Notification

[TCP alarm notification]

Specify whether to perform TCP alarm notification notification in the On/Off in the following cases:

- When an alarm occurs (TCP alarm notification notification destination [Alarm] field)
- When the remaining space on the SD memory card is notified (TCP alarm notification notification destination [Diag.] field)
- When there is insufficient free space on the SD memory card. (TCP alarm notification notification destination [Diag.] field)
- SD memory card recognition error (TCP alarm notification notification destination [Diag.] field)
- SD memory card write failure (TCP alarm notification notification destination [Diag.] field)



[Notice]

- TCP alarm notification notifications are notified in the order from [Notification Destination 1] (only for the notification destinations checked in the [Alarm] or [Diag.] field).

[Additional alarm data]

Use the On/Off to set whether to notify the operation detection alarm detection area number with TCP alarm notification.

[Destination port number]

Set the receiving port number of the TCP alarm notification notification destination.

Setting range : 1 ~ 65535

The following port numbers cannot be set because they are used on this unit.

20、 21、 22、 23、 25、 42、 53、 67、 68、 69、 80 110、 123、 161、 162、 443、 554、 995、 1883、 8883、 10669、 10670、 59000~61000

[Retry times]

Sets the number of retries when TCP alarm notification notification cannot be performed.

Setting range : 0 ~ 30

TCP alarm notification notification destination

[Destination 1] ~ [Address 48]

Sets the TCP alarm notification notification destination by IP address/hostname. Up to 48 destinations can be set.

[Alarm] field: Check this item to notify you when an alarm occurs.

[Diag.] field: When this checkbox is marked, the following errors will be reported: SD memory card remaining space notification, SD memory card insufficient space, SD memory card recognition error, and SD memory card write error.

[Transmission address] field: Enter the IP address/hostname of the notification destination.

Available Characters : Half mark alphanumeric characters and marks : . _ -

If you want to delete the set notification destination, press the [Delete] key of the notification destination you want to delete.

[Notification per Camera]

Set whether to set send by camera using the On/Off.

When [Notification per Camera] is set to [On], an alarm generated by the radar is notified when [Radar] is selected, and an alarm generated by the camera is notified when [Cameras] is selected in the same way.

[Notification per Radar detection/VMD area]

Select On/Off to enable or disable the Radar Detection/Motion Detection Area Sending setting.

When [Notification per
Radar detection/VMD area] is set to [On], the alarm notification is executed only when [Alarm Area No.] matches [Alarm area] number set for Radar Detection Alarm or Operation Detection Alarm.

Notification of alarms other than radar detection alarm and motion detection alarm is not executed. When using the send by radar detection/motion detection area function, select one of the detection objects in the alarm area of radar detection, and set the status of the alarm area in motion detection to [Enable].

[Alarm Area No.]

Setting range : 1~8



[Important]

- If you enter a hostname for the [Transmission address], you must configure the DNS in the [Network] tab on the Network page.
→ [10.11.2 Setting HTTP Alarm Notification](#)
- Check that the notification destination is set correctly. If there are no notification destinations, delays in TCP alarm notification notifications or missing transmissions may occur.

10.11.2 Setting HTTP Alarm Notification

HTTP alarm notification

[Destination 1] ~ [Address 5]

Set the IP address/hostname of the HTTP server to be notified of the HTTP alarm. You can set up to 5 recipients.

Available Characters : Half mark alphanumeric characters and marks : . _ -

Input example:

Http://IP address:Port number or http://Hostname:Port number

Https://IP address:Port number or https://Hostname:Port number

[Alarm] field

When this checkbox is marked, HTTP alarm notification is performed when an alarm occurs.

[Diag.] field

When this checkbox is marked, HTTP alarms are notified when the remaining space of the SD memory card is notified, when there is insufficient free space on the SD memory card, when an error occurs during SD memory card recognition, when the Extension software trial period expires, or when an error occurs during SD memory card writing.

[Delete] button

Clicking this button deletes all notification destinations, user names, passwords, notification data, and advanced settings for that item.

[Username]

Enter the username for accessing the HTTP server.

Number of characters that can be entered:0 to 63 characters

Characters that cannot be entered:Two-byte or one-byte symbol"& ; ¥

[password]

Enter the password for accessing the HTTP server.

Number of characters that can be entered:0 to 63 characters

Characters that cannot be entered:Two-byte or one-byte symbol"&



[Notice]

- Authenticate Basic or Digest by requesting authentication from the HTTP server.

[Notification data]

Set the notification content to be attached to the back of the HTTP server set to [Destination 1] ~ [Address 5].

Available Characters :Half mark alphanumeric characters and marks



[Notice]

- Enabling the HTTP alarm function may cause the credentials (username and password) of the HTTP server to be compromised on the network when an alarm is sent to the HTTP server.
- The total number of characters of the notification destination (including [http://]) and [Notification data] is limited to 256 characters.
- Be sure to enter [Notification data] beginning with a slash (/).
- If the HTTP alarm notification fails, it is recorded in the system log.
- If [Notification data] is left blank and [Set] is pressed, [/cgi-bin/comalarm.cgi?CMD=01] is also set.

Example :

If [http://192.168.0.100] is set as the notification destination and [/cgi-bin/comalarm.cgi?CMD=01] is set as the [Notification data], the HTTP alarm notification "http://192.168.0.100/cgi-bin/comalarm.cgi?CMD=01" is executed.

11 Advanced Networking Settings [Network]

The Network page is used to configure settings related to the network.

The Network page consists of the [Network] and [Advanced] tabs.

11.1 [Network] to set up networking

On the Network page, click the [Network] tab. For details on how to display and operate the advanced settings menu, refer to the User's Manual.

The following information is required to configure the network settings.

Contact your network administrator or Internet service provider.

- IP address
- Subnet Mask
- Default gateway (if using a gateway server router)
- HTTP
- Primary Server Address for DNS, Secondary Server Address (if DNS is used)



[Notice]

- For the address setting of each server, contact your network administrator.
- To access the Security Radar over the Internet by connecting to the router, you must configure a separate HTTP port number and use the port forwarding feature of the router to do the address-translation.

For details, refer to the router's instruction manual.

- The port forwarding function is used to convert a global IP address to a private IP address, such as [Static IP Masquerading] or [Network Address Translation (NAT)]. This feature is configured on the router.

IPv4 Network

[Network Settings]

Selects how to set IP addressing.

[Fixed IP]: Set the IP by typing it into the [IP address(IPv4)].

[DHCP]: Use the DHCP function to set the IP addressing. If you cannot obtain the IP address from the DHCP server, set the IP address to 192.168.0.10. Then, if you obtained a IP address

from the DHCP server, change it to that IP address.

[Auto (AutoIP)]: Use the DHCP function to set the IP addressing. If the DHCP server is not found, the IP is automatically set.

[Auto (Omakase)]: Use the DHCP function to view the network address information. Set the unused IP address as a fixed IP address. The IP address to be set is automatically determined by the camera within the subnet mask. If the DHCP server is not found, set the IP to 192.168.0.10.



[Notice]

- If autoconfiguration (AutoIP) is unable to retrieve the IP address from the DHCP server, search for an unused IP address in the same network between 169.254.1.0 and 169.254.254.255, and set the IP address.

[IP address(IPv4)]

When the DHCP function is not used, enter the IP address of this machine. Make sure that the IP is unique to the PC or other networked cameras.



[Notice]

- You cannot use more than one IP address even if you use the DHCP feature. Contact your network administrator for the DHCP server settings.

[Subnet mask]

Enter the subnet mask of this machine when the DHCP function is not used.

[Default Gateway]

If you do not want to use the DHCP function, enter the default gateway of this machine.



[Notice]

- If you use the DHCP feature, you cannot use more than one IP address for the default gateway. Contact your network administrator for the DHCP server settings.

[DNS]

Set whether to obtain the DNS server address automatically ([Auto]) or enter the address manually ([Manual]).

If set to [Manual], the IP addressing of the DNS server must be set.

If you use the DHCP feature, you can set it to [Auto] to get the DNS server address automatically.

Contact your system administrator for the settings.

[Primary server address], [Secondary server address]

If you are using [DNS] with [Manual], enter the IP of the DNS server.

For the IP of the DNS server, contact your administrator.

[Host name]

Enter the hostname to be used for the DHCP function.

Number of characters that can be entered: 1 to 64 characters

Available Characters: Single-byte alphanumeric characters and single-byte symbols ". " "-"

IPv6 Network



[Important]

- When accessed via IPv6, streamed video cannot be displayed on the live image screen. If you want to view the streamed video in the live image window, please visit the IPv4.

[Manual]

Set whether to set the IPv6 address manually with [On]/[Off].

[On]: Enter the IPv6 address manually.

[Off]: The IPv6 cannot be entered manually.

[IP address(IPv6)]

If [Manual] is set to [On], you must enter the IPv6 address manually.

Please input so that it does not overlap with other devices.



[Notice]

- When connecting across routers with manually configured IP addresses, use a IPv6 compatible router and enable the auto-configuration feature for IPv6 addresses.

Also, set a IPv6 address that includes the prefix information given by the IPv6 compatible router. For details, refer to the instruction manual for your router.

[Default Gateway]

Enter the default gateway of the IPv6 network of this machine when [Manual] of the IPv6 network is [On].

[DHCPv6]

Specify whether to use the DHCP function of the IPv6 with [On]/[Off].

Configure the DHCP server so that PC that do not use the DHCP function and other networked cameras do not have the same IP addressing. For server settings, contact your network administrator.

[Primary DNS server address], [Secondary DNS server address]

Enter the IPv6 of the DNS server. For the IPv6 of the DNS server, contact your administrator.

Shared by IPv6/v4

[HTTP port]

Assign port numbers individually.

Configurable port number:1~65535

The following port numbers cannot be set because they are used on this unit.

20、21、22、23、25、42、53、67、68、69、80、110、123、161、162、443、554、995、1883、8883、10669、10670、59000~61000



[Notice]

•Some ports may not be accessible depending on the browser. If you no longer have access, use the HTTPS or the i-port PRO Setup Tool (iCT) to change the port number.

[Baud rate]

Select the data communication speed from the following. In general, it is recommended to keep the default setting of [Auto].

[Auto]:The communication speed is set automatically.

[100 M-Full]:100 Mbps full duplex

[100 M-Half]:100 Mbps half duplex

[10 M-Full]:10 Mbps full duplex

[10 M-Half]:10 Mbps half duplex

[Max RTP packet size]

Sets whether to limit the RTP packet size sent from the camera when viewing camera images using the RTP. Normally, it is recommended to keep the [Unrestricted (1500 byte)] setting.

If the packet-size of the communication line to be used is limited, select [Restricted (1280 byte)].

Contact your network administrator for the maximum packet size of the communication line.

[HTTP max segment size(MSS)]

Sets whether to limit the maximum segment size (MSS) sent from the camera when viewing camera images using the HTTP. Normally, it is recommended to use the default settings.

If the maximum segment size (MSS) of the communication line to be used is limited, select

[Restricted (1024 byte)]/[Restricted (1280 byte)]. Contact your network administrator for the

maximum segment size (MSS) of the communication line.

[Bandwidth control(bit rate)]

Select the amount of data to deliver:

[Unlimited]/[128kbps]/[256kbps]/[384kbps]/[512kbps]/[768kbps]/ [1024kbps]/[2048kbps]/
[4096kbps]/[6144kbps]/[8192kbps]/[10240kbps]/[15360kbps]/[20480kbps]/[25600kbps]/
[30720kbps]/[35840kbps]/[40960kbps]/[51200kbps]/[61440kbps]



[Notice]

- If you set the [Bandwidth control(bit rate)] to a low value, the Snapshot button may not work depending on the usage. If so, select [JPEG] on the Live-screen page and run the snapshot with the smallest Image capture size delivered.

[IP Quick Setting Valid]

Set the time to enable the operation of the network setting from the IP Easy Setup software to either [20min] or [Unlimited] after the machine starts up.

[20 minutes]:You can enable the camera settings in the IP Easy Setup software only for 20 minutes after the machine starts up.

[Unlimited]:Enables the camera-setup operation in the IP Easy Setup software at any time.



[Notice]

- The camera view in the IP Easy Setup software is always enabled and the camera view can be opened.

[ONVIF®]

Set whether to use the ONVIF function with [On]/[Off].

[Enable]:The ONVIF function can be used.

[Disable]:The ONVIF function cannot be used.

11.2 [Advanced] for advanced networking settings

On the Network page, click the [Advanced] tab. For details on how to display and operate the advanced settings menu, refer to the User's Manual.

This section describes how to set up the SMTP (mail) and SNMP, MQTT functions.

Clicking the link to each item takes you to the respective setting page.



[Notice]

- For details on the settings of the NTP, UPnP, HTTPS, DDNS, QoS, SRTP, LLDP items, see the User's Manual.

11.2.1 Setting Mail Sending

[E-mail notification]

Set whether to send e-mail notification in the following cases in the On/Off.

When an alarm occurs (Email notification destination [Alarm] field)

When the remaining space of the SD memory card is notified (mail notification destination [Diag.] field)

When there is insufficient free space on the SD memory card. (E-mail notification destination [Diag.] field)

SD memory card recognition error (E-mail notification destination [Diag.] field)

SD memory card write failure (TCP alarm notification notification destination [Diag.] field)

[Alarm image attachment]

Set whether to attach images when sending e-mails by detecting alarms on the On/Off.

[Image Capture Size]

Displays the Image capture size of the images attached to the e-mail.



[Reference]

Displays the Image capture size for which you have viewed the [JPEG - Camera] settings in the [Image] settings on the [Image/Audio].



[Important]

[640x360] The following Image capture size settings can be used for proper operation.

[SMTP server address]

Enter the IP address or hostname of the SMTP server to which you want to send the email.

Number of characters that can be entered: 1 to 128 characters

Available Characters : Half mark alphanumeric characters and marks : . _ -

[SMTP port]

Enter the port number to send email to.

Configurable port number: 1 ~ 65535

The following port numbers cannot be set because they are used on this unit.

20、21、22、23、42、53、67、68、69、80、110、123、161、162、443、554、995、1883、8883、10669、10670、59000 ~ 61000

[POP server address]

If you selected [POP before SMTP] for [Type], enter the IP address/hostname of the POP server.

Number of characters that can be entered:1 to 128 characters

Available Characters :Half mark alphanumeric characters and marks : . _ -



[Important]

•To enter the hostname of the [SMTP server address] [POP server address], you must configure the DNS in the [Network] tab on the Network page.

→[11.1 \[Network\] to set up networking](#)

Authentication

[Type]

Select the authentication method for sending mail from the following options.

None :Do not authenticate

POP before SMTP:Prior to sending an email, authenticate the POP server receiving the email.

SMTP:Authenticate the SMTP server.



[Notice]

•If you do not know how to authenticate to send an email, contact your network administrator.

[Username]

Enter the user name to access the server.

Number of characters that can be entered:0 to 32 characters

Characters that cannot be entered:Two-byte or one-byte symbol"&"; ¥

[password]

Enter the password to access the server.

Number of characters that can be entered:0 to 128 characters

Characters that cannot be entered:Two-byte or one-byte symbol"&

[Sender's E-mail address]

Enter the sender's email address.

The entered mail address is displayed in the [From (sender)] field of received mail.

Number of characters that can be entered:3 to 128 characters

Available Characters :Half mark alphanumeric characters and marks @ . _ -

[SSL]

If you want to send [Alarm Notification] or [Diag.] email notifications SSL encrypted, set this to [On]. When set to [On], the authentication method is set to [SMTP]. Set the [Username] and [password] for authenticating.



[Notice]

- SSL may not be supported on some SMTP servers.
- The SMTP over SSL method is supported. STARTTLS is not supported.
- If set to [On], you may need to set the SMTP port number to 465. Check with your provider for details.

[Notification Destination 1] to [Notification Destination 4]

Set the e-mail address of the notification destination. You can set up to 4 recipients.

Number of characters that can be entered:3 to 128 characters

Available Characters :Half mark alphanumeric characters and marks @ . _ -

If you want to delete the set e-mail address, press [Delete] button of the e-mail address you want to delete.

[Terminal 1]:Mail notification is sent when an alarm occurs at terminal 1.

[Terminal 2]:Mail notification is sent when an alarm occurs at terminal 2.

[Terminal 3]:Mail notification is sent when an alarm occurs at terminal 3.

[Motion detection]:An e-mail notification is sent when an operation detection occurs.

[Denial Detection]:Email notification when disturbance detection occurs.

[Command Alarm]:Sends an e-mail notification when a command alarm is entered.

[Sound Detection]:An e-mail notification is sent when a sound detection occurs.

[ShockDetect]:An e-mail notification is sent when an impact is detected.

[Installation angle error detection]:An e-mail notification is sent when an installation angle error is detected.

[Radar Detection]:An e-mail notification is sent when a radar detection occurs.

[Tamper Detection]:An e-mail notification is sent when a radar jam detection occurs.

[Diagnostics]:

-SD memory card remaining space notification

-When there is not enough space in the SD memory card

-When the SD memory card is recognized



[Notice]

- The details of the [E-mail subject] and [E-mail body] that you set later will not be reflected in the diagnostic e-mail that is notified when the [Diag.] field is checked.

[E-mail subject(Alarm)]

Enter the subject of the alarm email.

Number of characters that can be entered:0 to 50 characters

Use Camera Title:The camera title is displayed in the mail subject.

Alarm source:Add an alarm factor to the email subject.

[E-mail subject(Diag.)]

Enter the subject of the diagnostic email.

Number of characters that can be entered:0 to 50 characters

Use Camera Title:The camera title is displayed in the mail subject.

Occurrence time:The occurrence time %% is added to the mail body. The %% part is sent with the time at which the alarm occurred (hour:minute:second).



[Notice]

- When there is no free space on the SD memory card, [SD memory card is FULL.] or when an error occurs on the SD memory card, the message [The SD memory card cannot be recognized.] is sent.
- By describing substitute characters in the mail body, the cause type and time of alarm occurrence can be assigned automatically.

Alternate character alarm cause: %p%, time of occurrence: %t%

(Example of use)

When an operation detection alarm occurs at 19:13:24 after the following character strings are set in the mail text

Message text setting: %p% alarm occurred on %t%.

Email body to be sent: ["VMD" alarm occurred on 19:13:24]

If the body is blank, the [Menu language] of the [Basic] determines the language of the email that is sent.

When [Japanese] is specified, mail is sent in Japanese. Otherwise, mail is sent in English.

[Terminal 1 (Up to 10 characters)]

Enter the name of terminal 1 used for the alarm source in the mail text.

Characters that cannot be entered:Single-byte characters&

[Terminal 2 (Up to 10 characters)]

Enter the name of terminal 2 used for the alarm source in the mail text.

Characters that cannot be entered:Single-byte characters&

[Terminal 3 (Up to 10 characters)]

Enter the name of terminal 3 used for the alarm source in the mail text.

Characters that cannot be entered:Single-byte characters&

E-mail notification example

Email format when the [Use the camera title] check Box is specified in the email subject and the

alarm cause/time check Box is specified in the email body

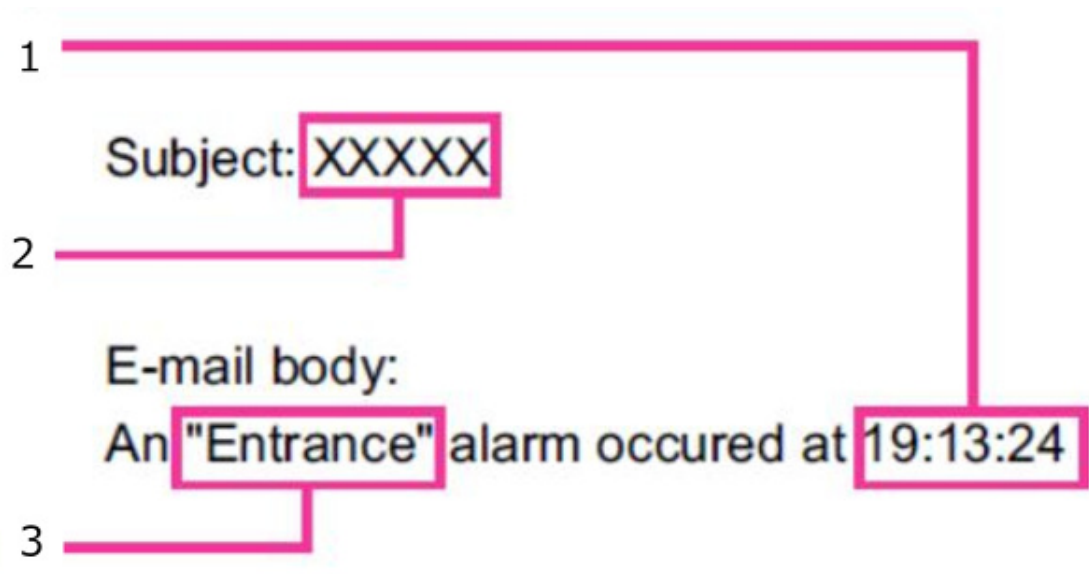

1. The alarm occurrence time is given.
2. The camera title is used for the mail subject.
3. The name set in the terminal names 1 to 3 that are the cause of the alarm is assigned.

11.2.2 Set the SNMP

Here, you can make settings related to the SNMP function. You can check the status of this machine by connecting using the SNMP Manager. To use the SNMP function, check with your network administrator.

SNMP setupFixed number

[SNMP Settings]

Enable or disable the SNMP function.



[Notice]

- If [SNMP Settings] is set to [Disable], [SNMP Agent Settings] [SNMP Trap Settings] cannot be set.

SNMP agent-setupFixed number

[SNMP version]

Select the SNMP version that you want to use.

[SNMPv1/v2]: The SNMPv1/v2 is enabled.

[SNMPv3]: The SNMPv3 is enabled.

[SNMPv1/v2/v3]: The SNMPv1/v2/v3 is enabled.

SNMPv1/v2 – [Community]

Enter the community name to be monitored.

Number of characters that can be entered: 0 to 32 characters

Characters that cannot be entered: Two-byte characters

Initial setting: Blank



[Important]

- When using the SNMP function in SNMPv1/v2, be sure to enter the community name. If the community name is blank, the SNMP function cannot be used. Also, do not set community names that can be easily guessed. (e.g. public)

SNMPv1/v2 – [Manager address]

Enter the IP of the SNMP manager to allow requests when the SNMP version is v1, v2. If blank, allows requests from all IP addresses.

Number of characters that can be entered: 1 to 128 characters

Available Characters : Half mark alphanumeric characters and marks : . /



[Notice]

- Enter [IP Address/Subnet Mask Length] to limit the IP addresses of the SNMP Manager that permits requests on a per-subnet basis.
For example, if you enter [192.168.0.1/24], SNMP manager requests between [192.168.0.1] and [192.168.0.254] are allowed.

[SNMPv3] – [Username]

Sets the username for the SNMPv3.

Number of characters that can be entered: Blank or 1 to 32 characters

Characters that cannot be entered: Two-byte or one-byte symbol " & ; ¥

[SNMPv3] – [Authentication method]

Displays the SNMPv3 authentication method.



[Notice]

- The [Authentication method] operates in [MD5] when upgrading from the [Authentication method] setting to [MD5]. Clicking the [Set] button changes the [Authentication method] to [SHA1].

[SNMPv3] – [Encryption method]

Select the SNMPv3 encryption method from the DES/AES.

[SNMPv3] – [password]

Sets the password for the SNMPv3.

Number of characters that can be entered:Blank or 8 to 20 characters

Characters that cannot be entered:Two-byte or one-byte symbol"&

[SNMPv2-MIB system setup](#)**Fixed number**

[Name]

Enter the device to manage this machine using the SNMP function.

Number of characters that can be entered:0 to 32 characters

Characters that cannot be entered:Two-byte characters

[Location]

Enter the location where this machine is installed.

Number of characters that can be entered:0 to 32 characters

[Contact]

Enter the administrator's email address or phone number.

Number of characters that can be entered:0 to 255 characters

Characters that cannot be entered:Two-byte characters

[SNMP trapping settings](#)

[SNMP trap setting]

Sets the SNMP trap-notification On/Off.

[Destination of Trap] – [Address]

Enter the destination address for SNMP trap-notification.

Number of characters that can be entered:1 to 128 characters

Available Characters :Half mark alphanumeric characters and marks : .

[Notification Destination] – [Port number]

Enter the port number of the SNMP trap-notification destination.

Configurable port number:1~65535

The following port numbers cannot be set because they are used on this unit.

20、21、22、23、42、53、67、68、69、80、110、123、161、162、443、554、995、1883、
8883、10669、10670、59000~61000



[Important]

•The IPv6 address and hostname cannot be used as the notification destination.

[SNMPv2c] – [Community]

Enter the community name to which the SNMP trap notification should be notified.

Number of characters that can be entered:0 to 32 characters

Characters that cannot be entered:Two-byte characters

Trap notification settingFixed number

[SNMP Generic trap] – [coldStart] – [Enable/Disable]

If Box is checked, a trap (SNMPv2-MIB::coldStart) will be notified when the camera is started.

[SNMP Generic trap] – [coldStart] – [Notification string]

Set the character string to extend the trap when this machine starts up to notify you.

Number of characters that can be entered:0 to 32 characters

Available Characters :0 to 9 (one-byte), A to Z (one-byte, upper case, lower case), single-byte symbol! " # \$ % & ' () * + , - . / : ; = ?

[SNMP Generic trap] – [linkUp] – [Enable/Disable]

If Box is checked, a trap (SNMPv2-MIB::linkup) will be notified when this machine is linked up.

[SNMP Generic trap] – [linkUp] – [Notification string]

Set the character string to be used to extend the trap when this machine is linked up.

Number of characters that can be entered:0 to 32 characters

Available Characters :0 to 9 (one-byte), A to Z (one-byte, upper case, lower case), single-byte symbol! " # \$ % & ' () * + , - . / : ; = ?

[SNMP Generic trap] – [authenticationFailure] – [Enable/Disable]

If Box is checked, a trap (SNMPv2-MIB:: authenticationFailure) is notified when an SNMP authorization error occurs.

[SNMP Generic trap] – [authenticationFailure] – [Notification string]

If you want to extend the trap when an SNMP authentication error occurs and notify you of it, set the character string.

Number of characters that can be entered:0 to 32 characters

Available Characters :0 to 9 (one-byte), A to Z (one-byte, upper case, lower case), single-byte symbol! " # \$ % & ' () * + , - . / : ; = ?

[Alarm]–[Terminal 1]–[Enable/Disable]

If Box is checked, a trap is notified when an alarm occurs at terminal 1.

[Alarm]–[Terminal 1]–[Notification string]

Set the character string used for the trap notification of [Pin 1].

Number of characters that can be entered:0 to 32 characters

Available Characters :0 to 9 (one-byte), A to Z (one-byte, upper case, lower case), single-byte symbol! " # \$ % & ' () * + , - . / : ; = ?

[Alarm]–[terminal 2]–[Enable/Disable]

checking If Box is checked, trapping will be notified when an alarm occurs at terminal 2.

[Alarm]–[Terminal 2]–[Notification string]

Set the character string used for the trap notification of [Pin 2].

Number of characters that can be entered:0 to 32 characters

Available Characters :0 to 9 (one-byte), A to Z (one-byte, upper case, lower case), single-byte symbol! " # \$ % & ' () * + , - . / : ; = ?

[Alarm]–[Terminal 3]–[Enable/Disable]

If Box is checked, a trap is notified when an alarm occurs at terminal 3.

[Alarm]–[Terminal 3]–[Notification string]

Set the character string used for the trap notification of [Terminal 3].

Number of characters that can be entered:0 to 32 characters

Available Characters :0 to 9 (one-byte), A to Z (one-byte, upper case, lower case), single-byte symbol! " # \$ % & ' () * + , - . / : ; = ?

[Alarm] – [VMD] – [Enable/Disable]

If Box is checked, a trap is notified when an operation is detected.

[Alarm] – [VMD] – [Notification string]

Sets the text used for [VMD] trapping notifications.

Number of characters that can be entered:0 to 32 characters

Available Characters :0 to 9 (half-pitch), A to Z (half-pitch, uppercase, lowercase), half-pitch symbol! " # \$ % & ' () * + , - . / : ; = ?

[Alarm] – [Audio detection] – [Enable/Disable]

If Box is checked, a trap is notified when a sound is detected.

[Alarm] – [Audio detection] – [Notification string]

Sets the text used for [Audio detection] trapping notifications.

Number of characters that can be entered:0 to 32 characters

Available Characters :0 to 9 (one-byte), A to Z (one-byte, upper case, lower case), single-byte symbol! " # \$ % & ' () * + , - . / : ; = ?

[Alarm]–[Impact Detection]–[Enable/Disable]

If Box is checked, a trap is notified when an impact is detected.

[Alarm]–[Impact Detection]–[Notification string]

Set the character string to be used for trap notification in [Shock Detection].

Number of characters that can be entered:0 to 32 characters

Available Characters :0 to 9 (one-byte), A to Z (one-byte, upper case, lower case), single-byte symbol! " # \$ % & ' () * + , - . / : ; = ?

[Alarm] – [Command alarm] – [Enable/Disable]

If Box is checked, a trap is notified when a command alarm occurs.

[Alarm] – [Command alarm] – [Notification string]

Sets the text used for [Command alarm] trapping notifications.

Number of characters that can be entered:0 to 32 characters

Available Characters :0 to 9 (one-byte), A to Z (one-byte, upper case, lower case), single-byte symbol! " # \$ % & ' () * + , - . / : ; = ?

[Alarm] – [Installation angle abnormality detection] – [Enable/Disable]

If Box is checked, trapping will be notified when an installation angle error is detected.

[Alarm] – [Installation angle abnormality detection] – [Notification string]

Sets the text used for [Installation angle abnormality detection] trapping notifications.

Number of characters that can be entered:0 to 32 characters

Available Characters :0 to 9 (one-byte), A to Z (one-byte, upper case, lower case), single-byte symbol! " # \$ % & ' () * + , - . / : ; = ?

[Alarm] – [Radar detection] – [Enable/Disable]

If Box is checked, a trap is notified when a radar detection occurs.

[Alarm] – [Radar detection] – [Notification string]

Sets the text used for [Radar detection] trapping notifications.

Number of characters that can be entered:0 to 32 characters

Available Characters :0 to 9 (one-byte), A to Z (one-byte, upper case, lower case), single-byte symbol! " # \$ % & ' () * + , - . / : ; = ?

[Alarm] – [Tamper Detection] – [Enable/Disable]

If Box is checked, a trap is notified when a radar disturbance detection occurs.

[Alarm] – [Tamper Detection] – [Notification string]

Sets the text used for [Tamper Detection] trapping notifications.

Number of characters that can be entered:0 to 32 characters

Available Characters :0 to 9 (one-byte), A to Z (one-byte, upper case, lower case), single-byte symbol! " # \$ % & ' () * + , - . / : ; = ?

[SD Memory Card]–[Diag.]–[Enable/Disable]

If Box is checked, traps are notified in the following cases:

- When the remaining space on the SD memory card is notified
- When there is not enough space in the SD memory card
- When the SD memory card is recognized

[SD Memory Card]–[Diag.]–[Notification string]

Sets the text used for [Diag.] trapping notifications.

Number of characters that can be entered:0 to 32 characters

Available Characters :0 to 9 (one-byte), A to Z (one-byte, upper case, lower case), single-byte symbol! " # \$ % & ' () * + , - . / : ; = ?

11.2.3 Set the MQTT

Here, you can make settings related to the MQTT(Message Queuing Telemetry Transport) function. When an alarm occurs, you can notify the MQTT server of the event operation by the alarm.

[MQTT settings]

Set whether to enable the MQTT function by [On]/[Off].

If it is set to [On], or if it is [On] when the camera starts up, it connects to the configured server.

Notifies the server of the setting contents when the set alarm occurs.

[On]: Use the MQTT function.

[Off]: Do not use MQTT function.

Server

[Address]

Enter the IP or hostname of the MQTT server to be notified when an alarm occurs.

Number of characters that can be entered: 1 to 128 characters

Available Characters : Half mark alphanumeric characters and marks : . _ -

[Protocol]

Select from the MQTT over SSL/MQTT over TCP the protocol used to connect to the MQTT server.

MQTT over SSL: Encrypts communication with the MQTT server by SSL.

MQTT over TCP: Does not encrypt communication with the MQTT server.

[Username]

Enter the username for accessing the MQTT server.

Number of characters that can be entered: 0 to 32 characters

Characters that cannot be entered: Two-byte or one-byte symbol "&"; ¥

[password]

Enter the password for accessing the MQTT server.

Number of characters that can be entered: 0 to 32 characters

Characters that cannot be entered: Two-byte or one-byte symbol "&"

Route CA certificate Writing

[Installation]

Install the root CA certificate issued by the certificate authority.

In the [Open File Dialog] that appears when you click the [Select File] button, select the file of the root CA certificate issued by the certification authority, and click the [Execute] button to install the root CA certificate.

Root CA certificates can be in PEM or DER format.

[Info]

The root CA certificate is displayed.

[Disable]:The root CA certificate is not installed.

[Root CA certificate hostname]:Displayed when the software is already installed.

Clicking [Leave] allows you to view more information about the root CA certificate.

Clicking [Delete] button removes the installed root CA certificate.

[Server certificate verification]

If [MQTT over SSL] is selected for [Protocol] and [Server certificate verification] is [Enable], the server certificate is verified using the root CA certificate registered when the SSL is connected.



[Notice]

· If [Server certificate verification] is [Enable], install the root CA certificate.

Notification setting**Fixed number**

[Alarm]

Checks for alarm events that notify the MQTT server.

[terminal 1]:Notifies the MQTT server when an alarm occurs at terminal 1.

[Terminal 2]:Notifies the MQTT server when an alarm occurs at terminal 2.

[Terminal 3]:Notifies the MQTT server when an alarm occurs at terminal 3.

[VMD]:Notifies the MQTT server when an operation detection occurs.

[Audio detection]:Notifies the MQTT server when a sound detection occurs.

[Command alarm]:Notifies the MQTT server when a command alarm is entered.

[Impact Detection]:Notifies the MQTT server when an impact is detected.

[Installation angle abnormality detection]:Notifies the MQTT server when an installation angle error is detected.

[Radar detection]:Notifies the MQTT server when a radar detection occurs.

[Tamper Detection]:Notifies the MQTT server when a radar jam detection occurs.

[Transmission interval]

Sets the MQTT topicname to be sent. Topics have a hierarchical structure separated by a/character.

Number of characters that can be entered:1 to 128 characters

Available Characters :Half-pitch alphanumeric characters and symbols

Inhibited characters:Half-pitch symbols ¥

[Payload]

Sets the MQTT message payload.

Number of characters that can be entered:1 to 128 characters

Available Characters :Half-pitch alphanumeric characters and symbols

Inhibited characters:Half-pitch symbols ¥

[QoS]

Selects the QoS from 0, 1, and 2. $0 < 1 < 2$ provides higher communication quality.

0:By QoS0, messaging is delivered up to once. Messages are not guaranteed to arrive at the server.

1:By QoS1, messaging is delivered at least once. Messages are guaranteed to arrive at the destination, but they may be duplicated.

2:QoS2 delivers the messaging exactly once. Messages are guaranteed to arrive only once with no excess or shortage.

[Retain]

Select this checkbox if you want the MQTT server to save the message that was notified last.

12 [Schedule] to set advanced scheduling

On the Schedule page, schedule the following items.

- Radar detection stop
- Radar disturbance detection stop
- Alarm input enabled (terminals 1, 2, 3)
- Alarm input enabled (terminal 1)
- Alarm input enabled (terminal 2)
- Alarm input enabled (terminal 3)
- Operation Detection Enable
- Denial Detection Enable
- Image disclosure permission
- SD recording
- Sound Detection Enable
- Scene file
- Email sending permission
- Allow all alarms to be detected (only for Schedule 8 and Mie).
- [Automatic scheduling]Daytime: Picture 1/Night: Picture 2 (Schedule 1 only)
- Restart the Camera (Schedule 8 only)
- Impact Detection Enable

The scheduling page consists only of the [Schedule] tabs. Up to eight schedules can be set.

- 1 Select the Box of the week you want [Schedule] to schedule.



[Notice]

- For use with [Access permission], set [User auth.] on the [User auth.] tab to [On] and [Host auth.] on the [Host auth.] tab to [Off].
→ Refer to the user manual.
- For use with [SD memory recording], set [Recording format] on the [SD memory card] tab. Then, set [Save trigger] to [Schedule].
- Schedule 1 [<Automatic scheduling>Daytime: Image Quality 1/Night: Image Quality 2] and [Image Quality 1:Scene1 (Scene File 1)] [Image Quality 2:Scene2 (Scene File 2)] [Image Quality 3:Scene3 (Scene File 3)] [Image Quality 4:Scene4 (Scene File 4)] of Schedule 2 to 8 cannot be selected at the same time.

- 2 To specify the time, set the time by clicking [▼]. If you do not want to set the timezone, select the [24h] checkbox.
- 3 After completing the settings, clicking [Set] displays the settings at the bottom of the window.



[Notice]

- The colors displayed in Schedule 1 to Schedule 8 indicate the colors of the lines displayed in the schedule field at the bottom of the screen.
- When the operation mode of Schedules 1 to 8 is set to [Off], the operation of the following items is enabled at all times.
 - Alarm input enabled (terminals 1, 2, 3)
 - Alarm input enabled (terminal 1)
 - Alarm input enabled (terminal 2)
 - Alarm input enabled (terminal 3)
 - Operation Detection Enable
 - Denial Detection Enable
 - Audio Detection Enable
 - Image disclosure permission
 - Impact Detection Enable
 - Allow all alarms to be detected (only for Schedule 8 and Mie.

12.1 How to set the schedule

Schedule

Schedules

Schedule 1 (White)	Schedule mode VMD permission	<input checked="" type="checkbox"/> Mon <input checked="" type="checkbox"/> Tue <input checked="" type="checkbox"/> Wed <input checked="" type="checkbox"/> Thu <input type="checkbox"/> Fri <input type="checkbox"/> Sat <input type="checkbox"/> Sun <input type="checkbox"/> 24h <input type="text" value="00"/> : <input type="text" value="00"/> - <input type="text" value="00"/> : <input type="text" value="00"/>
Schedule 2 (Blue)	SCD permission	<input checked="" type="checkbox"/> Mon <input checked="" type="checkbox"/> Tue <input checked="" type="checkbox"/> Wed <input checked="" type="checkbox"/> Thu <input checked="" type="checkbox"/> Fri <input checked="" type="checkbox"/> Sat <input checked="" type="checkbox"/> Sun <input type="checkbox"/> 24h <input type="text" value="22"/> : <input type="text" value="00"/> - <input type="text" value="05"/> : <input type="text" value="00"/>
Schedule 3 (Green)	Impact detection permission	<input checked="" type="checkbox"/> Mon <input checked="" type="checkbox"/> Tue <input checked="" type="checkbox"/> Wed <input checked="" type="checkbox"/> Thu <input checked="" type="checkbox"/> Fri <input checked="" type="checkbox"/> Sat <input checked="" type="checkbox"/> Sun <input type="checkbox"/> 24h <input type="text" value="22"/> : <input type="text" value="00"/> - <input type="text" value="05"/> : <input type="text" value="00"/>
Schedule 4 (Red)	Off	<input type="checkbox"/> Mon <input type="checkbox"/> Tue <input type="checkbox"/> Wed <input type="checkbox"/> Thu <input type="checkbox"/> Fri <input type="checkbox"/> Sat <input type="checkbox"/> Sun <input type="checkbox"/> 24h <input type="text" value=""/> : <input type="text" value=""/> - <input type="text" value=""/> : <input type="text" value=""/>
Schedule 5 (Black)	Off	<input type="checkbox"/> Mon <input type="checkbox"/> Tue <input type="checkbox"/> Wed <input type="checkbox"/> Thu <input type="checkbox"/> Fri <input type="checkbox"/> Sat <input type="checkbox"/> Sun <input type="checkbox"/> 24h <input type="text" value=""/> : <input type="text" value=""/> - <input type="text" value=""/> : <input type="text" value=""/>
Schedule 6 (Yellow)	Off	<input type="checkbox"/> Mon <input type="checkbox"/> Tue <input type="checkbox"/> Wed <input type="checkbox"/> Thu <input type="checkbox"/> Fri <input type="checkbox"/> Sat <input type="checkbox"/> Sun <input type="checkbox"/> 24h <input type="text" value=""/> : <input type="text" value=""/> - <input type="text" value=""/> : <input type="text" value=""/>
Schedule 7 (Light blue)	Off	<input type="checkbox"/> Mon <input type="checkbox"/> Tue <input type="checkbox"/> Wed <input type="checkbox"/> Thu <input type="checkbox"/> Fri <input type="checkbox"/> Sat <input type="checkbox"/> Sun <input type="checkbox"/> 24h <input type="text" value=""/> : <input type="text" value=""/> - <input type="text" value=""/> : <input type="text" value=""/>
Schedule 8 (Purple)	Off	<input type="checkbox"/> Mon <input type="checkbox"/> Tue <input type="checkbox"/> Wed <input type="checkbox"/> Thu <input type="checkbox"/> Fri <input type="checkbox"/> Sat <input type="checkbox"/> Sun <input type="checkbox"/> 24h <input type="text" value=""/> : <input type="text" value=""/> - <input type="text" value=""/> : <input type="text" value=""/>

Scene settings linked to sunrise and sunset times [To scene setting \(image quality adjustment\)](#)
 When using this function, set the time zone. [Basic settings >>](#)

Auto Scheduler (Manual/ City Selection)

Latitude

Longitude

Altitude

Automatic calculation result
 Sunrise time :
 Sunset time :

Sunrise time + Minutes (-60 - 60)
 Sunset time + Minutes (-60 - 60)
The time of the automatic calculation result can be corrected between -60 minutes and +60 minutes.

	0:00	6:00	12:00	18:00	24:00
Mon					
Tue					
Wed					
Thu					
Fri					
Sat					
Sun					

The color of each schedule is not linked with the area color of "VMD area".
 When "VMD permission" is set, the VMD functions in all the areas set with "VMD area".
 "VMD permission" and "SCD permission" are required when assigning the period to be detected. Setting is not necessary when detection at any time.

- 1 In the [Schedule], select the Box of the week you want to schedule.
The day of the week is valid.
- 2 When specifying the time, specify the time by clicking [▼].
If you do not want to specify a timezone, tick [24h].
- 3 When you have finished configuring the settings, press [Set].
The settings are displayed at the bottom of the screen.

12.2 How to delete a schedule

- 1 Uncheck the day of the week Box for which you want to remove the schedule.
- 2 When you have finished configuring the settings, press [Set].
The schedule for the selected day is deleted.

12 [Schedule] to set advanced scheduling
 12.2 How to delete a schedule

Schedule

Schedules

Schedule 1 (White)	Schedule mode: <input type="text" value="Off"/>
	Time range: <input type="checkbox"/> Mon <input type="checkbox"/> Tue <input type="checkbox"/> Wed <input type="checkbox"/> Thu <input type="checkbox"/> Fri <input type="checkbox"/> Sat <input type="checkbox"/> Sun <input type="checkbox"/> 24h
Schedule 2 (Blue)	Schedule mode: <input type="text" value="Off"/>
	Time range: <input type="checkbox"/> Mon <input type="checkbox"/> Tue <input type="checkbox"/> Wed <input type="checkbox"/> Thu <input type="checkbox"/> Fri <input type="checkbox"/> Sat <input type="checkbox"/> Sun <input type="checkbox"/> 24h
Schedule 3 (Green)	Schedule mode: <input type="text" value="Off"/>
	Time range: <input type="checkbox"/> Mon <input type="checkbox"/> Tue <input type="checkbox"/> Wed <input type="checkbox"/> Thu <input type="checkbox"/> Fri <input type="checkbox"/> Sat <input type="checkbox"/> Sun <input type="checkbox"/> 24h
Schedule 4 (Red)	Schedule mode: <input type="text" value="Off"/>
	Time range: <input type="checkbox"/> Mon <input type="checkbox"/> Tue <input type="checkbox"/> Wed <input type="checkbox"/> Thu <input type="checkbox"/> Fri <input type="checkbox"/> Sat <input type="checkbox"/> Sun <input type="checkbox"/> 24h
Schedule 5 (Black)	Schedule mode: <input type="text" value="Off"/>
	Time range: <input type="checkbox"/> Mon <input type="checkbox"/> Tue <input type="checkbox"/> Wed <input type="checkbox"/> Thu <input type="checkbox"/> Fri <input type="checkbox"/> Sat <input type="checkbox"/> Sun <input type="checkbox"/> 24h
Schedule 6 (Yellow)	Schedule mode: <input type="text" value="Off"/>
	Time range: <input type="checkbox"/> Mon <input type="checkbox"/> Tue <input type="checkbox"/> Wed <input type="checkbox"/> Thu <input type="checkbox"/> Fri <input type="checkbox"/> Sat <input type="checkbox"/> Sun <input type="checkbox"/> 24h
Schedule 7 (Light blue)	Schedule mode: <input type="text" value="Off"/>
	Time range: <input type="checkbox"/> Mon <input type="checkbox"/> Tue <input type="checkbox"/> Wed <input type="checkbox"/> Thu <input type="checkbox"/> Fri <input type="checkbox"/> Sat <input type="checkbox"/> Sun <input type="checkbox"/> 24h
Schedule 8 (Purple)	Schedule mode: <input type="text" value="Off"/>
	Time range: <input type="checkbox"/> Mon <input type="checkbox"/> Tue <input type="checkbox"/> Wed <input type="checkbox"/> Thu <input type="checkbox"/> Fri <input type="checkbox"/> Sat <input type="checkbox"/> Sun <input type="checkbox"/> 24h

Scene settings linked to sunrise and sunset times [To scene setting \(image quality adjustment\)](#)
 When using this function, set the time zone. [Basic settings >>](#)

Auto Scheduler (Manual/ City Selection)

Latitude (-90.000000 - 90.000000)
 Longitude (-180.000000 - 180.000000)
 Altitude (m/500 - 9000)

Automatic calculation result
 Sunrise time :
 Sunset time :
 Sunrise time + Minutes (-60 - 60)
 Sunset time + Minutes (-60 - 60)
 Sunrise time and sunset time correction
 The time of the automatic calculation result can be corrected between -60 minutes and +60 minutes.

	0:00	6:00	12:00	18:00	24:00
Mon					
Tue					
Wed					
Thu					
Fri					
Sat					
Sun					

The color of each schedule is not linked with the area color of "VMD area".
 When "VMD permission" is set, the VMD functions in all the areas set with "VMD area".
 "VMD permission" and "SCD permission" are required when assigning the period to be detected. Setting is not necessary when detection at any time.

12.3 How to set the image quality to be changed by the sunrise time and sunset time

- 1 You can set the time of Sunrise and Sunrise from [Set scenes linked to Sunrise and Sunrise time].

[To Scene Settings (Picture Adjust)]

This link is used to adjust the image quality for scene settings.

[Basic]

Links to basic settings for setting the timezone.

[Auto-schedule (Select Manual/ City)]

Select how you want to enter the [Latitude] [Longitude] [Altitude].

[Not use]: Operation mode [<Automatic scheduling>Daytime: Disables Image Quality 1 (Scene 1)/Night: Image Quality 2 (Scene 2)].

[Manual]: Manually enter the [Latitude] [Longitude] [Altitude].

[(city name)]: The city list is displayed. The [Latitude] [Longitude] [Altitude] of the selected city is entered and used for the [Automatic calculation result].

[Latitude]

Enter the latitude of the region of the camera you are using.

Input range: -180 to 180 (decimal number up to 6 decimal places)

[Longitude]

Enter the longitude of the region of the camera you are using.

Input range: -90 to 90 (Valid up to 6 decimal places)

[Altitude]

Enter the local altitude for your location.

If it is blank, it is calculated by "10m".

Input range: -500 to 9000 (m)

[Automatic calculation result]

The sunrise and sunset times are calculated from the [Latitude] [Longitude] [Altitude]. If [Set] is not clicked, the calculated result is not reflected.

[Sunrise Time/Sunset Time Compensation]

Time correction is performed to the sunrise and sunset times of [Automatic calculation result] to determine the time to reflect the image quality.

Input range: -60 to 60 (minutes)

- 2 Press the [Set] key.

12 [Schedule] to set advanced scheduling

12.3 How to set the image quality to be changed by the sunrise time and sunset time

3 Configure the schedule settings.

For the setting method, refer to the following.

→[12 \[Schedule\] to set advanced scheduling](#)

13 Other

13.1 System log display

Display related to abnormal installation angle detection

Classification	Display contents	Details
Installation status	A change from the registered "installation angle" was detected.	•When a deviation from the registered installation angle is detected, it is recorded in the log.
	You have returned to the registered "Installation angle".	•It is recorded in the log when you return to the registered installation angle.

Error messages related to firmware upgrades

Classification	Display contents	Details
Upgrading the firmware	Version upgrade failed (Radar 1)	•Radar firmware up failed. Check that the firmware to be uploaded is correct, and try again. Alternatively, wait a few seconds and try again.
	Version upgrade failed (Radar 2)	

Radar self-diagnosis display

Classification	Display contents	Details
Manual Radar Self-Test	<Manual self-diagnosis>RADAR normal	•As a result of the manual radar self-test, a successful operation is logged.

Radar self-diagnostic error display

Classification	Display contents	Details
----------------	------------------	---------

Manual Radar Self-Test	<Manual self-diagnosis>RADAR error	•As a result of the manual radar self-test, it is logged that the radar is not working properly. Contact your original retailer.
Radar self-diagnosis	<Self-diagnosis>RADAR error	•As a result of the radar self-test, it is logged that the radar is not working properly. Contact your original retailer.

13.2 Troubleshooting

Review this table for symptoms before requesting service.

If you cannot correct any of these problems or if any symptoms other than those listed in this table occur, consult the retailer from whom the watch was purchased.

Phenomenon	Cause and Countermeasure	Reference
Cannot access from a web browser	•Are category 5e or higher cabled to the network connector?	Instruction Manual Installation
	•Is the link indicator (LINK) lit? If it is not lit, the LAN is not properly connected or the destination network is not working properly. Check the cable for loose connection and wiring.	Instruction Manual Installation
	•Check that the machine is turned on? Check that the machine is turned on.	Instruction Manual Installation
	•Is a valid IP address set for this machine?	User Manual

Phenomenon	Cause and Countermeasure	Reference
	<ul style="list-style-type: none"> • Are you accessing the wrong IP address? Use the following procedure to check connectivity. If Reply is returned from this machine at > ping IP addressing set for the machine at Windows command prompt, the machine is operating normally. If you do not receive a Reply, check the connection in the following way on the PC connected to the same network as the camera. If the PC firewall setting is enabled, temporarily cancel the setting and then perform the camera setting. • Start the IP Quick Setup software. Check the IP address of the camera. Then, access the IP address. • If the network settings (IP address, subnet mask, default gateway) are incorrect, restart the camera and change the network settings using the IP Easy Setup software within 20 minutes. • If initialization is performed by restarting the unit without a DHCP server, the IP is set to [192.168.0.10]. Then, re-set the IP address by accessing the machine (at this time, all machine settings are initialized). 	—
	<ul style="list-style-type: none"> • Have you set 554 to the HTTP port number? Use a port number other than 20, 21, 22, 23, 25, 42, 53, 67, 68, 69, 80, 110, 123, 161, 162, 443, 554, 995, 1883, 8883, 10669, 10670, 59000 to 61000 as the HTTP port number to use with this unit. 	User Manual

Phenomenon	Cause and Countermeasure	Reference
	<ul style="list-style-type: none"> •Is the set IP address duplicated with other devices? Is the set address inconsistent with the destination network/subnet? [When the instrument and PC are connected in the same subnet] Is the IP address of the instrument and PC set in the same subnet? Also, is [Use Proxy Server] set in the PC? When accessing this machine in the same subnet, it is recommended to set the address of this machine to [Remove from Proxy] address. [When this machine and the PC are connected to different subnets] Is the default gateway set for this machine incorrect? 	—
	<ul style="list-style-type: none"> •When using the HTTPS function, if you are using the [http://] to access? HTTPS, use the [https://] to access. You also need to enter the port number. From the support video page of the support site<Control No. :P0002>, <Control No. :P0003>See also. 	—

Phenomenon	Cause and Countermeasure	Reference
I can't access Security Radar from the website	<ul style="list-style-type: none"> •Are the network settings of this machine correct? Set the default gateway or DNS server address correctly. If you are using DDNS servicing, make sure that it is set correctly. •Have you configured [Default Gateway] in your network settings? Or have you configured it correctly? If it is IPv4, make sure to configure [Default Gateway] correctly in [Set]-[Network]-[IPv4 network]. 	11 Advanced Networking Settings [Network]

Phenomenon	Cause and Countermeasure	Reference
	<ul style="list-style-type: none"> • Is port forwarding configured on the router? If your router does not have UPnP functionality, port forwarding must be configured to enable Internet-based access to this unit. For the setting method, refer to the instruction manual of your router. • Is the UPnP function of the router disabled? Refer to the instruction manual of your router to enable the UPnP function. • Have you set up packet filtering to prohibit access to the router from the Internet? Please set up your router so that it can be accessed from the Internet. For the setting method, refer to the instruction manual of your router. 	11 Advanced Networking Settings [Network]
	<ul style="list-style-type: none"> • Is the IP address (local address) used in the local network being accessed? Check the IPv4 network settings, IPv6 network settings, and DDNS settings, and use the global address (or the URL registered in the DDNS service) and the port number of this machine as the IP address of this machine when using the Internet. 	11 Advanced Networking Settings [Network]

Phenomenon	Cause and Countermeasure	Reference
The certification screen is displayed continuously.	<ul style="list-style-type: none"> • Have you changed the user name or password? If you change the user name or password of a user who is logged in with a different web browser while accessing this machine, the authentication screen is displayed each time you switch the screen. Close the web browser and access the machine again. • Have you changed the [Authentication method] settings? If you changed the [Authentication method] settings, close the web browser and visit it again. 	—

Phenomenon	Cause and Countermeasure	Reference
It takes time to display the screen.	<ul style="list-style-type: none"> •Are you accessing in HTTPS mode? When accessing in HTTPS mode, it is decrypted, so it will be delayed depending on the specification of your PC. For the recommended specifications for PC, refer to the WEB guide for your model. 	—
	<ul style="list-style-type: none"> •Is this machine in the same local network accessed through a proxy? Set the PC so that it does not pass through a proxy. 	—
	<ul style="list-style-type: none"> •Are multiple users viewing camera images at the same time? If multiple users view camera images at the same time, the screen display may take a long time or the camera image may update slowly. 	—

Phenomenon	Cause and Countermeasure	Reference
Security Radar cannot be accessed from a mobile or tablet device	<p>For mobile devices:</p> <ul style="list-style-type: none"> •The URL is wrong. Or, at the end of the URL, is [/cam] not entered? Check that the URL is entered correctly. When accessing this machine from a mobile device, you need to enter [/cam] at the end of the URL used when accessing from the PC. <p>For tablet devices:</p> <ul style="list-style-type: none"> •Is the URL correct? Check that the URL is correctly entered. 	—
	<ul style="list-style-type: none"> •Is the SSL encryption method of the HTTPS of the handheld device or tablet device different from that of this machine? Set the [Connection] of this machine to [HTTP] and re-access. 	—
	<ul style="list-style-type: none"> •When using the HTTPS function, if you are using the [http://] to access? HTTPS, use the [https://] to access. You also need to enter the port number. From the support video page of the support site<Control No. :P0002>, <Control No. :P0003>See also. 	—

Phenomenon	Cause and Countermeasure	Reference
No Picture	•Have you exceeded the size of the image data that can be displayed on the mobile device or tablet device? For the restrictions on the image data size that can be displayed on the mobile device or tablet device, refer to the user's manual for your mobile device or tablet device.	—
The image is not updated	•Depending on the web browser or version, the image may not be updated or other problems may occur.	—
	•Image display may stop due to network congestion or centralized access to this unit. Request to acquire images by pressing [F5] on the PC keypad.	—
Camera image is not output (dark)	•Is the [Brightness] set to darken? Press the Brightness [Standard] button.	WEB guidance
The image is whitish.	•Have you set the [Brightness] to brighten up? Click the Brightness [Standard] button.? Move the [Adaptive black stretch] slider-bar to [-] to darken the picture.	WEB guidance
The image flickers.	•If you are concerned about flickering, set [Light control mode] to [Indoor scene].	WEB guidance

Phenomenon	Cause and Countermeasure	Reference
Images are not saved to the SD memory card.	•Check whether the SD memory card is inserted correctly or not.	—
	•Is the SD memory card formatted? Format the SD memory card.	—
Fail to read/write data from/to the SD memory card.	•[SD memory card] Is [-----MB/-----MB] displayed in [Remaining capacity]? Format SD memory card.	7.2 Setting an SD Memory Card [SD Memory Card]
	•In [Remaining capacity] on the [SD memory card] tab.[#####MB/#####Is MB] displayed? Check the password-lock setting.	7.2 Setting an SD Memory Card [SD Memory Card]

Phenomenon	Cause and Countermeasure	Reference
	<ul style="list-style-type: none"> • If you are using email notifications or TCP alarm notification's [Diag.] function, are you receiving an error identifying the SD memory card? • [Maintenance]-[Status]-[SD memory card] logging:<SD>Is the recognition error displayed? Format the SD memory card. 	7.2 Setting an SD Memory Card [SD Memory Card]
	<ul style="list-style-type: none"> • Is the SD memory card defective? The SD memory card has a limited number of rewrites. Replace the SD memory card. If the memory card is rewritten frequently, the card may have a limited service life. 	—

Phenomenon	Cause and Countermeasure	Reference
Cannot transmit voice	<ul style="list-style-type: none"> • Is the microphone and speaker connected correctly? Check if the connection is correct. • Voice transmission can be used only when connected via HTTPS. 	Instruction Manual Installation
No audio from our network disk recorders or PC software packages	<ul style="list-style-type: none"> • Some of our network disk recorders and PC software packages do not support [G.711]. Set the audio compression method to [G.726 (32 kbps)] or [AAC-LC]. 	8.5 Setting sound [Audio]
Live image pages images are not displayed.	<ul style="list-style-type: none"> • Press [F5] on the PC's keyboard. Alternatively, press [Live]. 	WEB guidance
Camera-shortcut icon does not appear on the PC's [Network]	<ul style="list-style-type: none"> • Have you added the UPnP's Windows component? Please add the UPnP's Windows component to your PC. 	Contact your PC vendor.

Phenomenon	Cause and Countermeasure	Reference
Images are not updated or displayed properly.	<ul style="list-style-type: none"> • The port of this machine may be filtered by the firewall function of the virus check software. Change the HTTP port number of this unit to a port number that is not subject to filtering. 	—

Phenomenon	Cause and Countermeasure	Reference
Various lamps do not light.	<ul style="list-style-type: none"> In the Advanced Settings menu [Basic], is the indicator setting set to [Off]? Set the indicator setting to [On]. 	User Manual
H.265 (or H.264) images are not displayed smoothly	<ul style="list-style-type: none"> The following contents may be improved. Check [Required PC settings] in the WEB manual. 	WEB guidance
The correct screen is not displayed when you click the Back button of the web browser.	<ul style="list-style-type: none"> Press [F5] on the PC keypad to refresh the window. 	—
[Access-intensive. Please execute after a while.] is displayed in Live image pages.	<ul style="list-style-type: none"> Change the [Bit Rate per Client*] setting for the stream to a lower value. Change the [Initial display stream] setting to a lower stream of [Max bit rate (per client) *]. 	8.3 Configuring Stream Settings [Video]
Characters in a message, such as a dialog message or an error message, are newline or part of the message is not displayed	<ul style="list-style-type: none"> It may be resolved by changing the settings of your PC. Right-click on the PC window, and change the display in the setting of [Display Settings] → [Change the size of text, apps, and other items]. 	—

13.3 SD Memory Card Directory Structure

13.3.1 About Security Radar Directory-Configuration

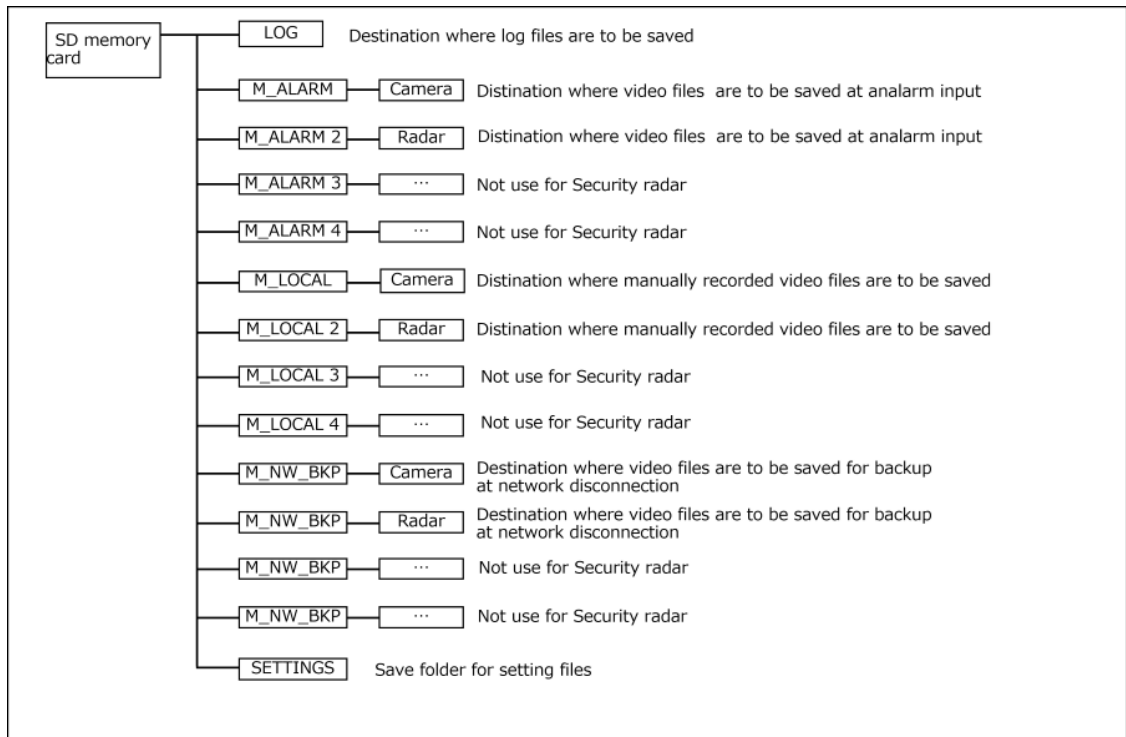

Calibration guide

Flow of Security Radar calibration

This manual explains how to calibrate the Security Radar according to the following steps.

1. **Overall flow**
2. **Simulation with System Design Tool**
3. **Preparing for i-PRO Configuration Tool**
4. **Radio interference avoidance**
5. **Security Radar calibration settings**

1. Overall flow

We recommend that you use the following procedures to perform Security Radar calibration. You can proceed without executing the parts marked with * in the following work items.

1. **Simulation using the system design tool (*)**
 - ① Placement Simulation: Simulates the placement of Security Radar and PTZ cameras.
 - ② Pre-Simulation of Radio Interference Avoidance by i-PRO Configuration Tool (* When 7 or more Security Radar are used): An interference simulation is performed based on the outcome of the System Design Tool.
 - ③ Prepare to Export to i-PRO Configuration Tool: Prepare and export to work with i-PRO Configuration Tool.
2. **Preparing for i-PRO Configuration Tool**
 - ① Installing the i-PRO Configuration Tool: Installs the i-PRO Configuration Tool.
 - ② Security Radar and PTZ Camera Discovery and Log-in Authentication: Connect the Security Radar and PTZ cameras to the i-PRO Configuration Tool.
3. **Radio Interference Avoidance (* Only when more than one Security Radar is used)**
 - ① Automatic channel assignment to Security Radar: Automatically sets the channel to avoid radio interference with Security Radar.
4. **Security Radar calibration settings**
 - ① Specify the configuration pattern: Specify whether the system design tool is linked or not, and whether PTZ cameras are linked.
 - ② Initial Security Radar setting: Sets the unit of measure for the Security Radar.
 - ③ System design tool link (* When simulated in advance): Imports the results of the system

design tool.

- ④ PTZ camera linking (* When PTZ camera linkage is used): Specify the PTZ camera linked with Security Radar.
- ⑤ Security Radar Calibration: Import maps into the Security Radar and calibrate their position, orientation, etc.
- ⑥ PTZ camera Calibration(*): Calibrates the position and orientation of the PTZ camera.
- ⑦ Latitude / longitude information setting (*): Sets latitude and longitude information to Security Radar.
- ⑧ Alarm notification settings (*): Configure alarm notification settings for Security Radar and PTZ cameras.
- ⑨ Radar Settings: Set Radar settings.

2. Simulation with System Design Tool

You can use the System Design Tool to simulate the placement of Security Radar and PTZ cameras. You can also use the System Design Tool to simplify the calibration settings when installing the Security Radar.

For detailed instructions on how to use the system design tool, refer to the Operating Instructions(https://i-pro.com/products_and_solutions/en/media/documentation_file/sdt_operation_guide_enpdf).

2.1 Launch the system design tool

Our system design tool(<https://sdt.i-pro.com/>) using a browser. Open and login to your account.

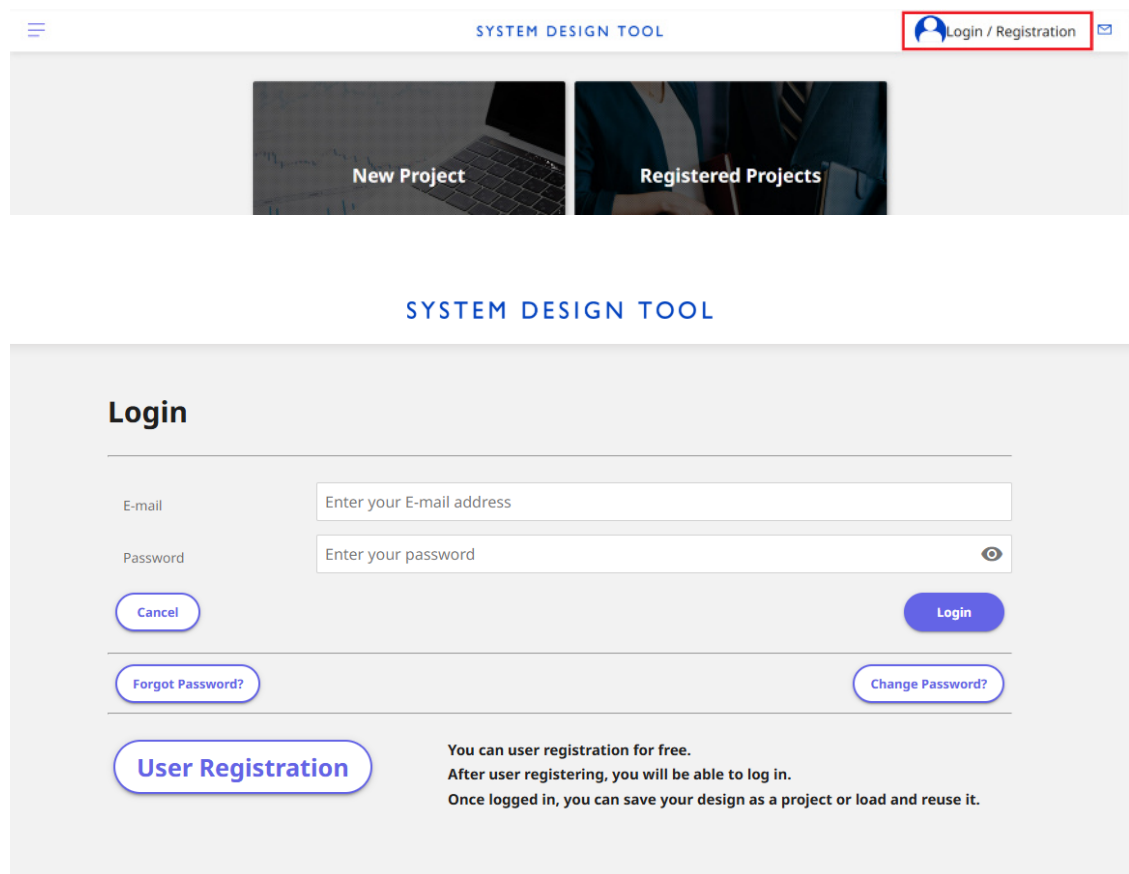

Starts the task by clicking [New Project].

SYSTEM DESIGN TOOL

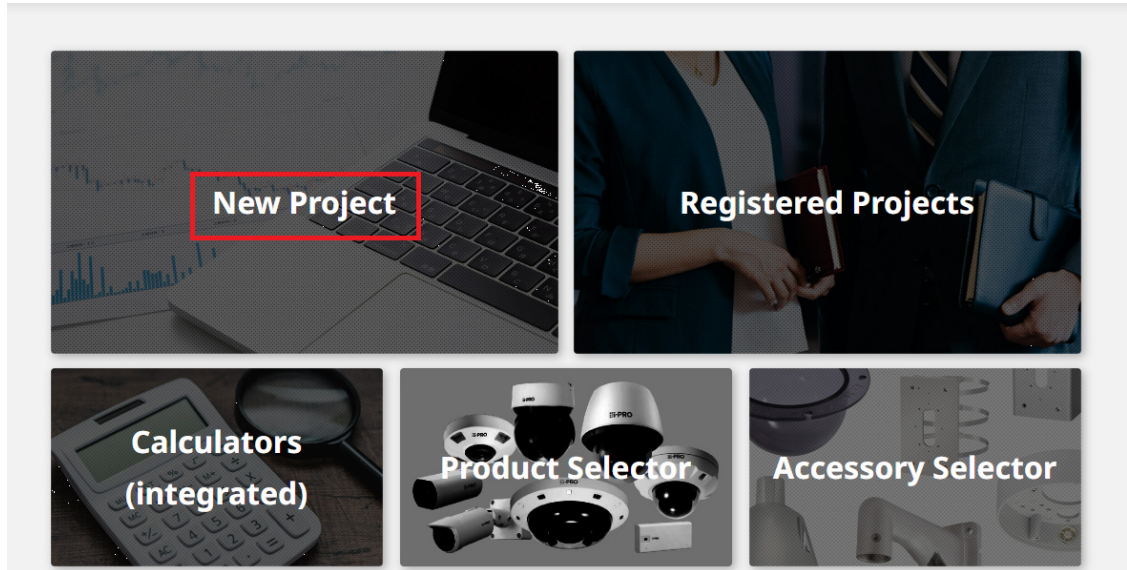

2.2 Adding Security Radar to Representative Models

Add Security Radar to a representative model. By making this setting, the Security Radar set for the typical model is set to the default setting when "2.4 Placing Security Radar on the Map" described later is executed.

Click the [Account Settings] icon in the upper-right corner of the screen to scroll the screen and open the [Representative Model Setting] items.

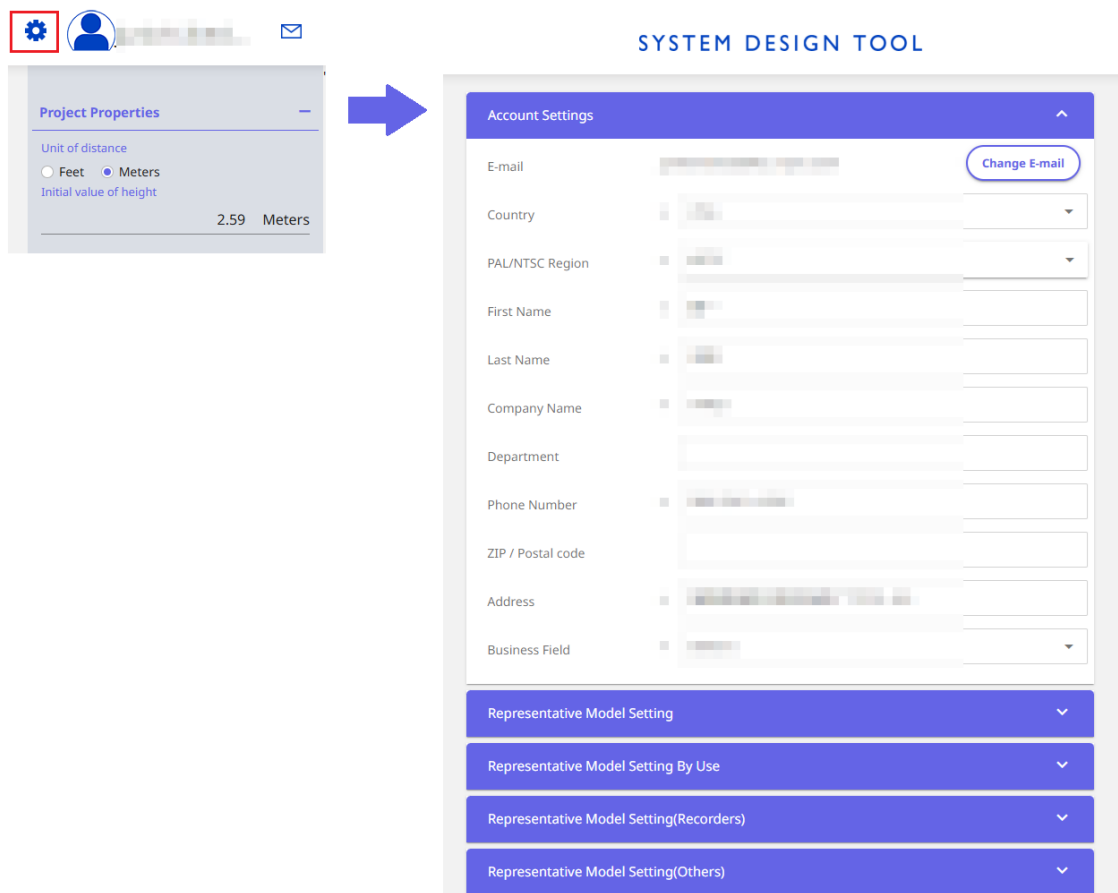

Select the [Security Radar] tab. Clicking Security Radar's [Select] opens the Security Radar selection window.

Specify the part number of the frequently used Security Radar and add Security Radar as a representative by clicking [Select].

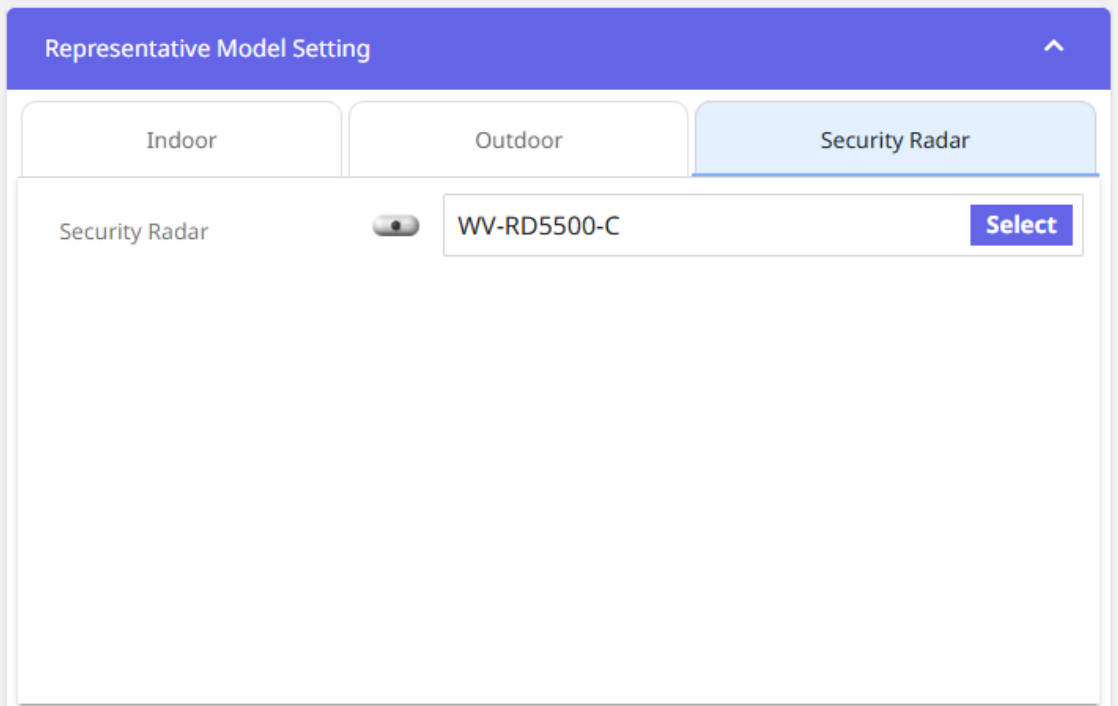

Security Radar Select

Sort by

Product Series

WV-RD5500-C

WV-RD5500-CS



Security Radar with built-in camera

select



Security Radar with built-in camera

select

2.3 Loading Map Data into System Design Tools

Open the Load Map window by clicking [Import Map].

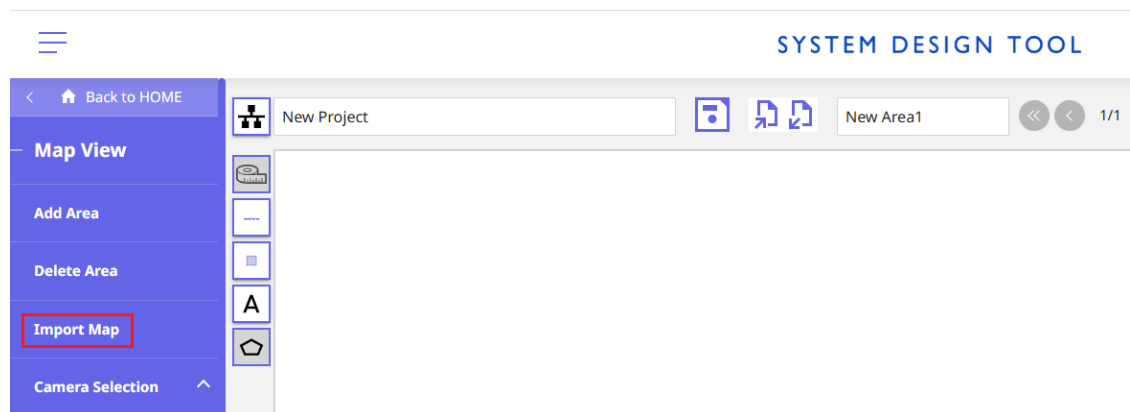

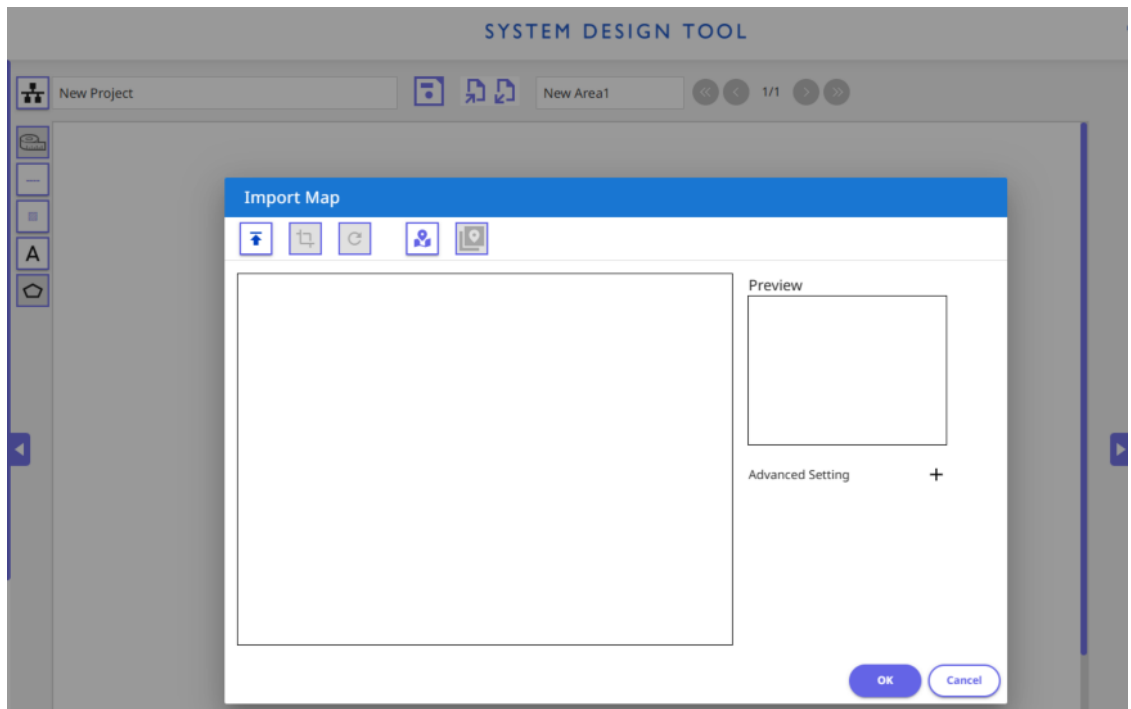

If you want to use the map images provided by the customer, specify the [Import Map] of a.
When simulating on a Google Map, specify the [Map Service] of b.

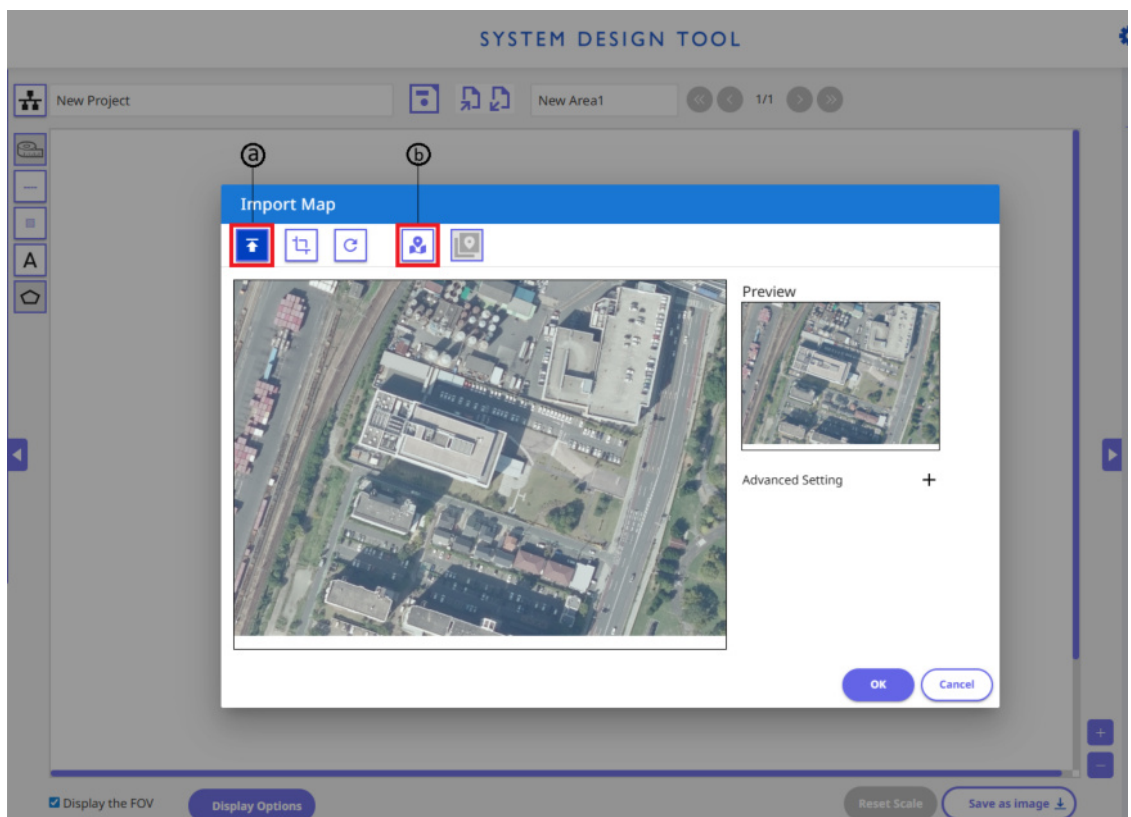

2.4 Placing the Security Radar on the Map

Select [Security Radar] from the left-hand menu and drag-and-drop it onto the map.

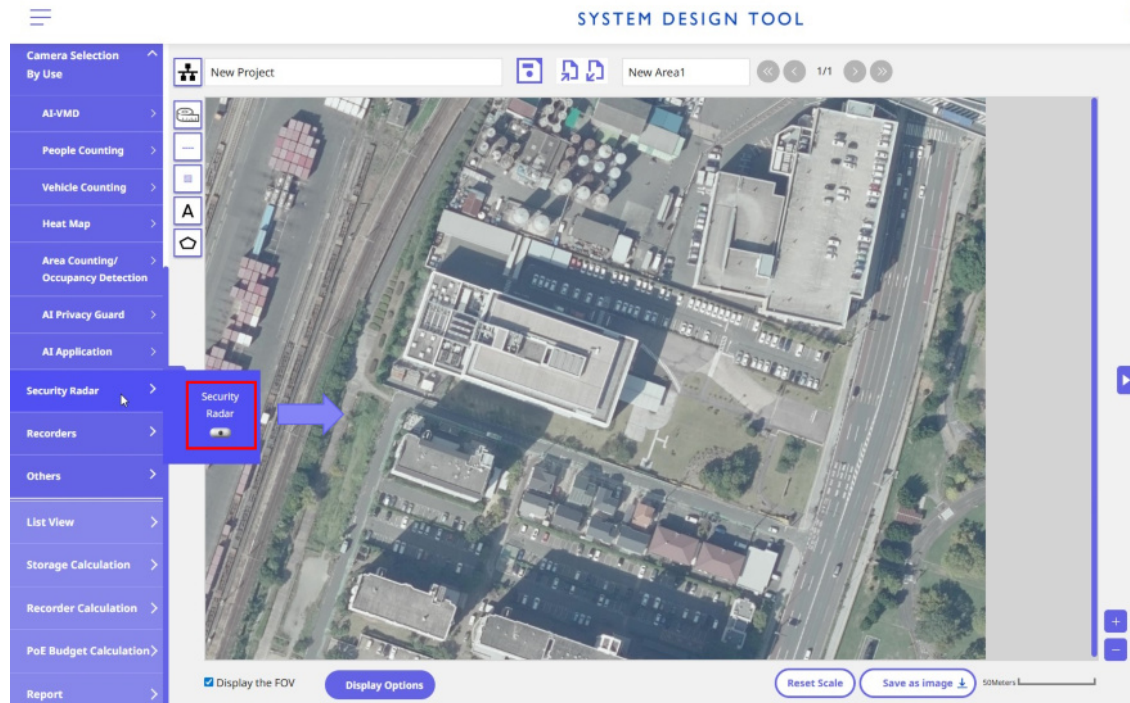

You can move the Security Radar by dragging and dropping it to the desired location in the Security Radar.

You can also change the orientation of the Security Radar by moving the human icon to the direction you want to monitor.

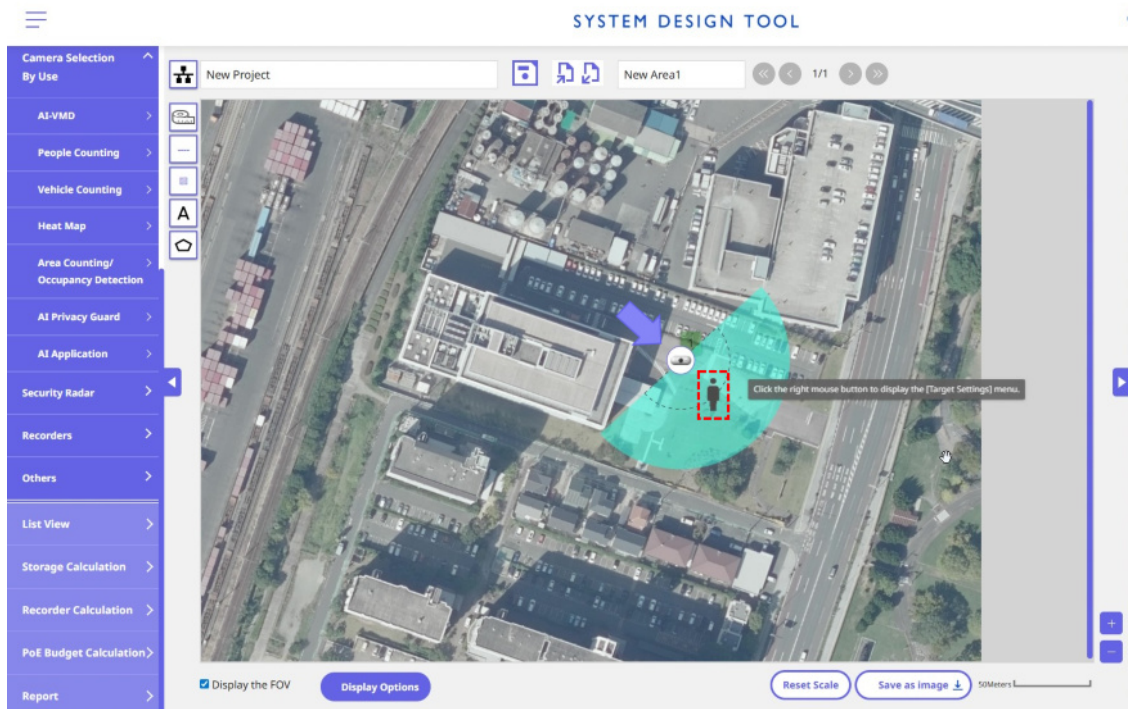

Notice

- Right-click the person icon and select [Target Settings] to select the human or vehicle. When you select a car, the search range will increase by approximately 1.4 times and change to a vehicle icon.

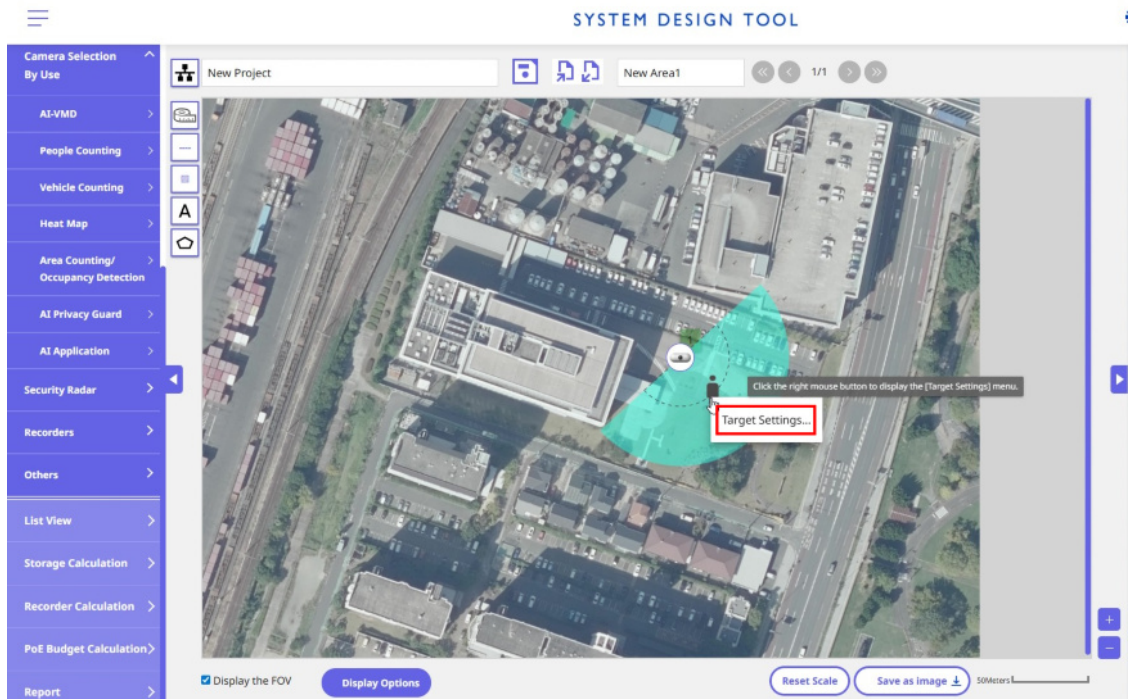

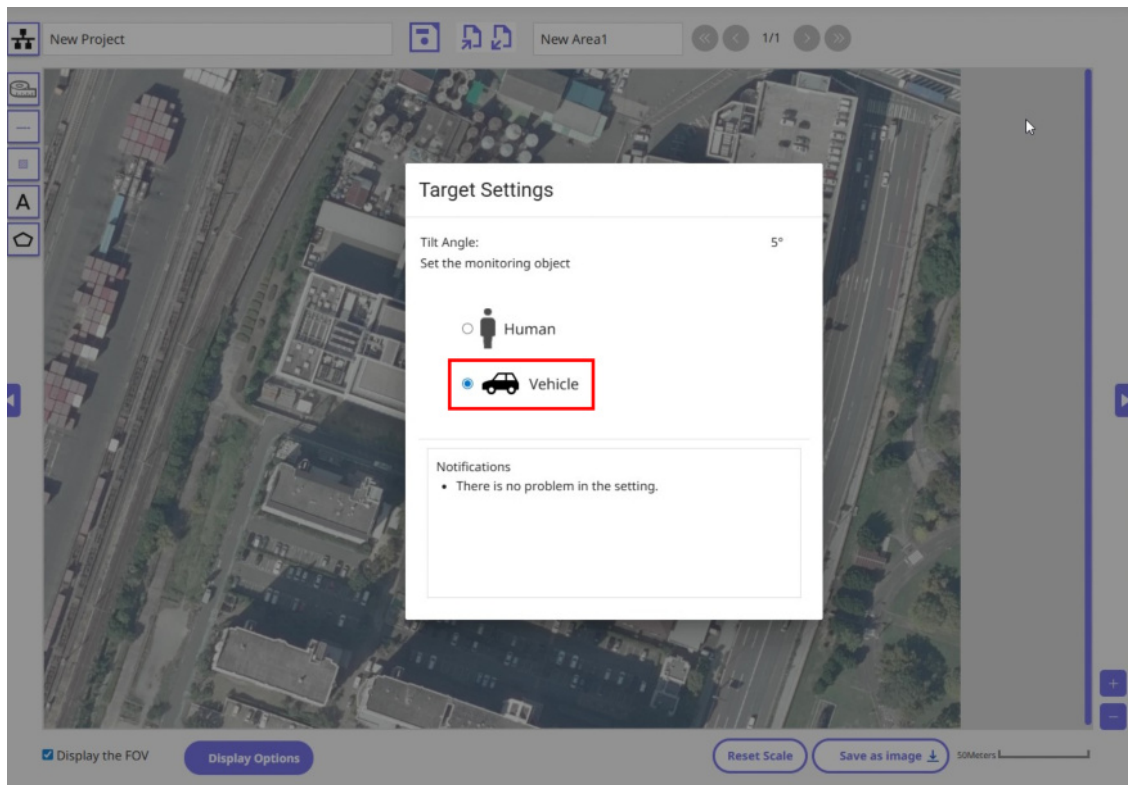

The Security Radar displays the detection area in a light blue semicircle.

By dragging and dropping the person icon and car icon, you can check whether it is within the detection range of Security Radar.

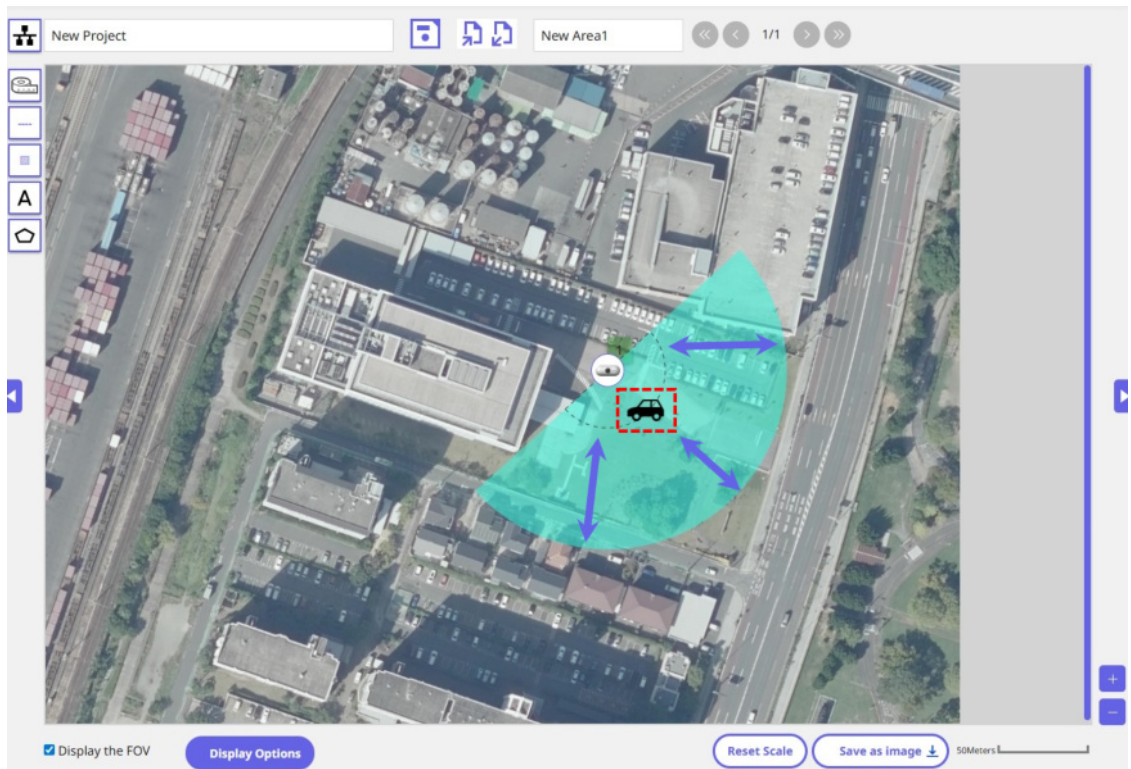

2.5 Entering Installation Information and Checking the Detection Range

Enter the height, tilt angle, and distance to check if the detection is possible.

The following shows how to check the detection area by moving the Security Radar tilt angle when the height is 3m and the detection distance (specification) 3–70m.

Height

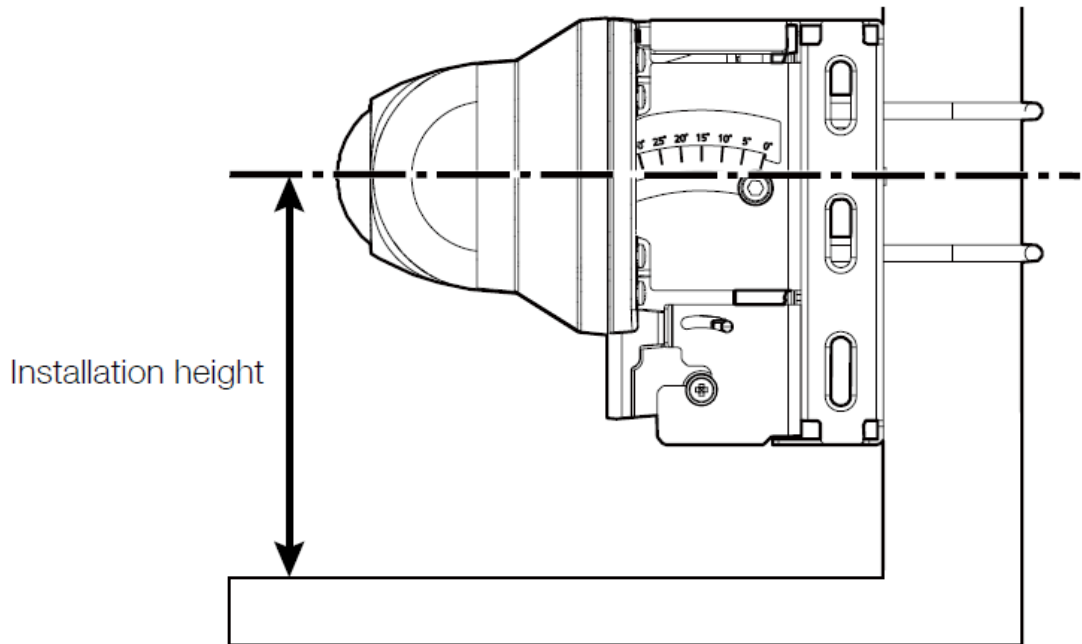

Downward tilt angle

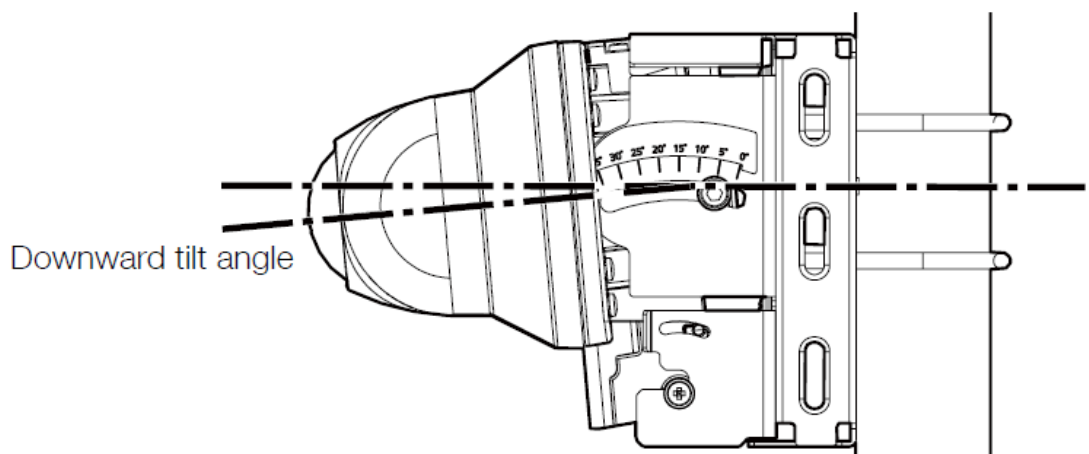

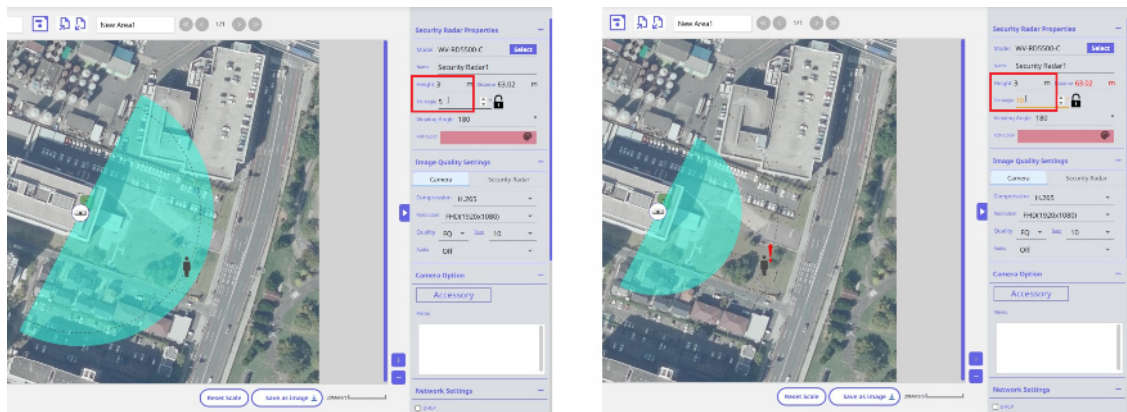

Left: Result when installed at a height of 3 m, tilt angle 5 degrees; Right: Result when installed at a height of 3 m, tilt angle 10 degrees.

It is displayed that it can be detected under the installation conditions shown in the figure on the left.

In the example shown in the figure on the right, the Security Radar becomes downward and the detection area becomes narrower, which means that detection cannot be performed at the assumed detection distance. Refer to "Installation height and downward tilt angle table" in Step 2 of the Instruction Guide for information on the detection area for the installation height and tilt angle.

2.6 PTZ Positioning the Camera on the Map

Choose [Camera Selection]–[Outdoor]–[PTZ Camera] from the left-hand menu. Then, drag-and-drop copies onto the map. You can use the same steps to position and simulate several PTZ cameras.

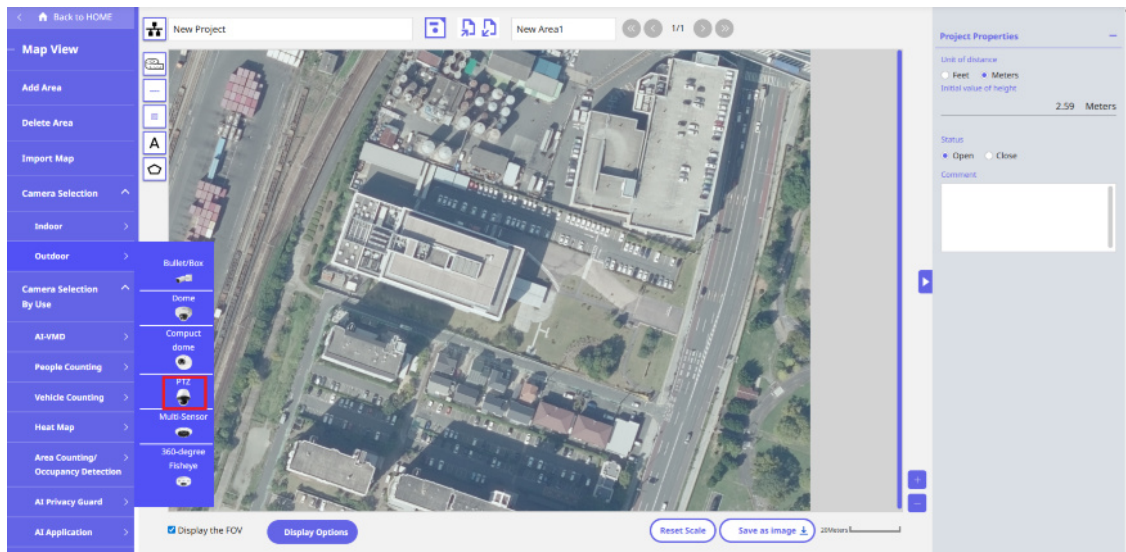

2.7 Exporting Project Files

The system design tool validation can be exported as a project file (.sdtj).

The exported project file uses i-PRO Configuration Tool and is used for checking Security Radar radar-to-radar interference and for calibration during installation.

- 1 Select the [Export to file].

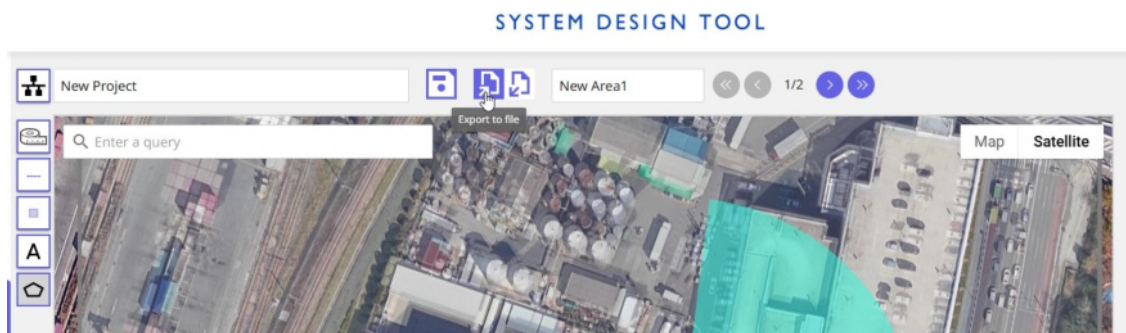

- 2 Select the [Continue].

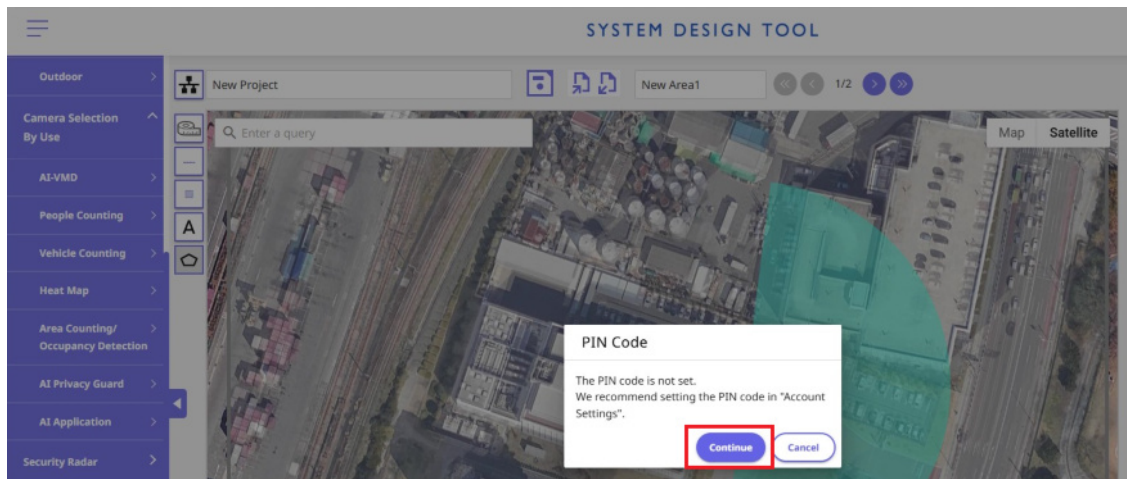

- 3 Confirm that the export is complete and select [Return].

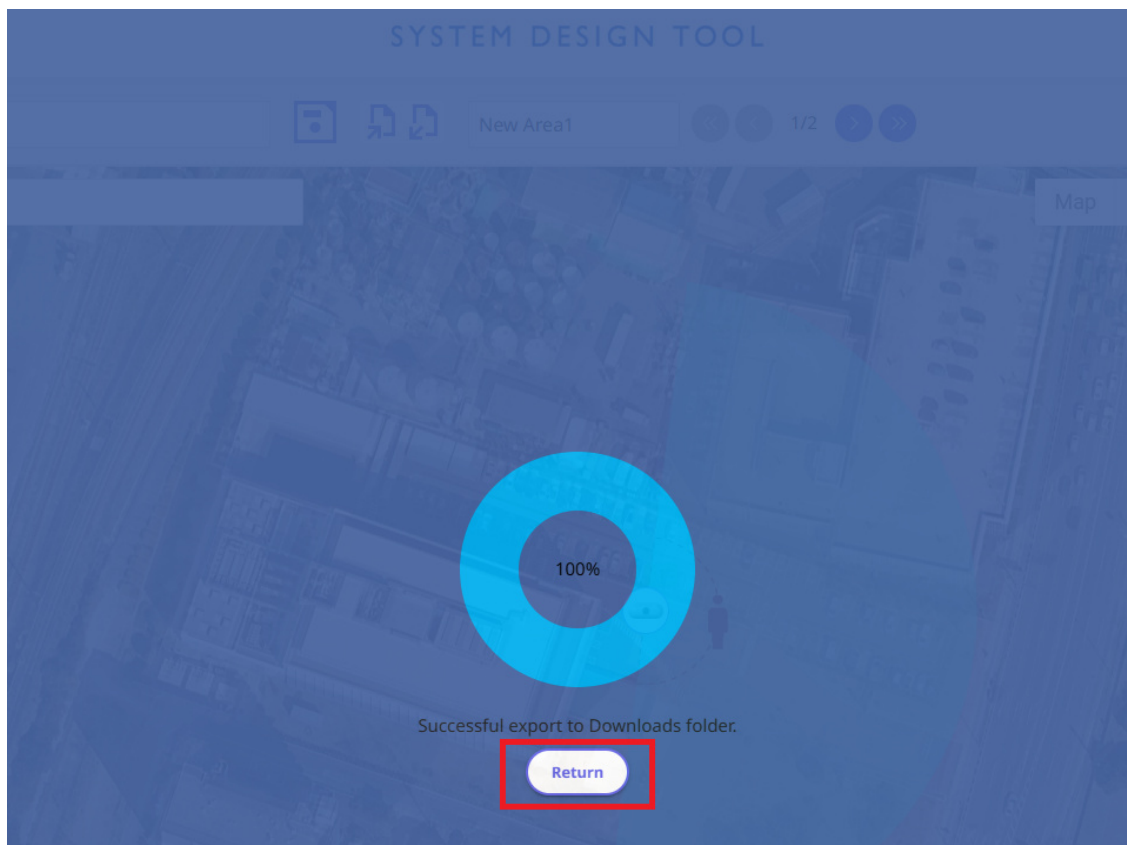

- 4 Make sure that the file is exported.

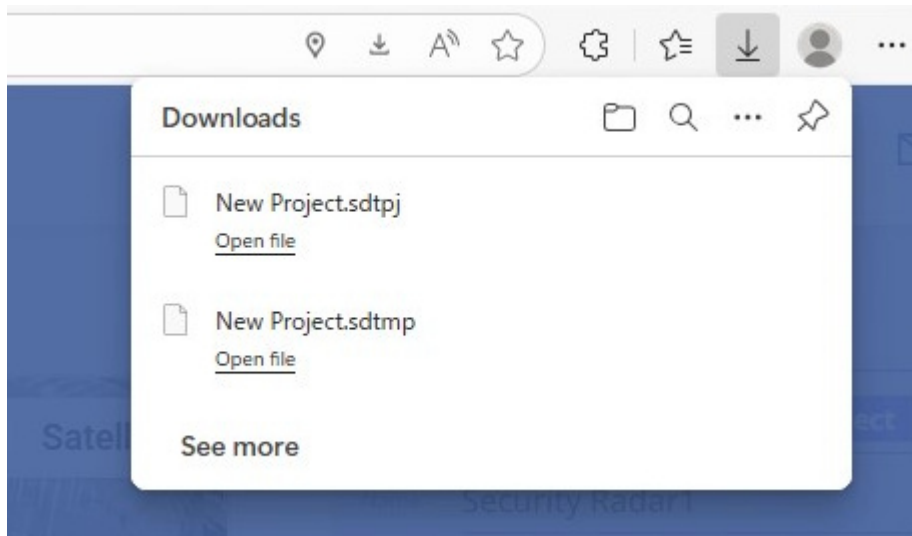

If [Use image files from local PC] is enabled, a confirmation window is displayed, and the local save file (.sdtmp) is saved at the same time when exporting.

Note that both files are required for use with i-PRO Configuration Tool.

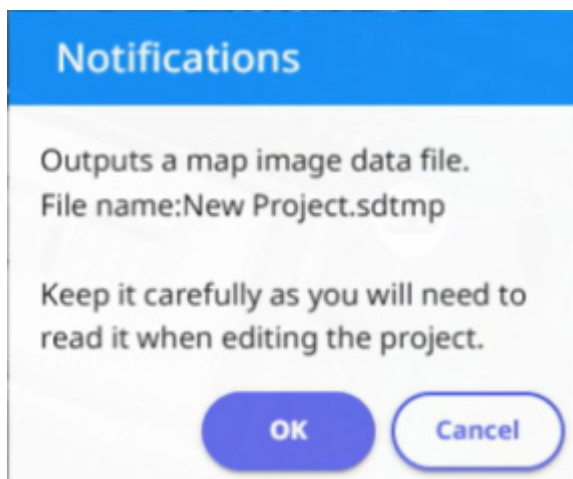

2.8 Pre-Simulation of Radio Interference Avoidance with i-PRO Configuration Tool

When seven or more Security Radar are used, radar interferences between the Security Radar must be checked at the timing-of-placement consideration.

You can use the i-PRO Configuration Tool [Radio Interference Avoidance] feature to check if there is interference between Security Radar.

Refer to "4. Radio Interference Avoidance" for detailed usage.

2.9 Preparing for Security Radar Calibration Configuration with i-PRO Configuration Tool

2.9.1 When using the specified map image

As Security Radar can capture as is, no preparations are required in advance. Export the file from "2.7 Exporting Project Files".

2.9.2 When using Map Service (Google Map)

Map service maps cannot be imported into Security Radar due to Google Map terms and conditions. If you want to use the simulated map service for Security Radar calibration, you need to prepare a map image, set the overlay image acquisition function, and then export it as a project file.

2.9.2.1 Import overlay image data into the system design tool

Import the map images that you have obtained separately by clicking [Import Overlay Image].

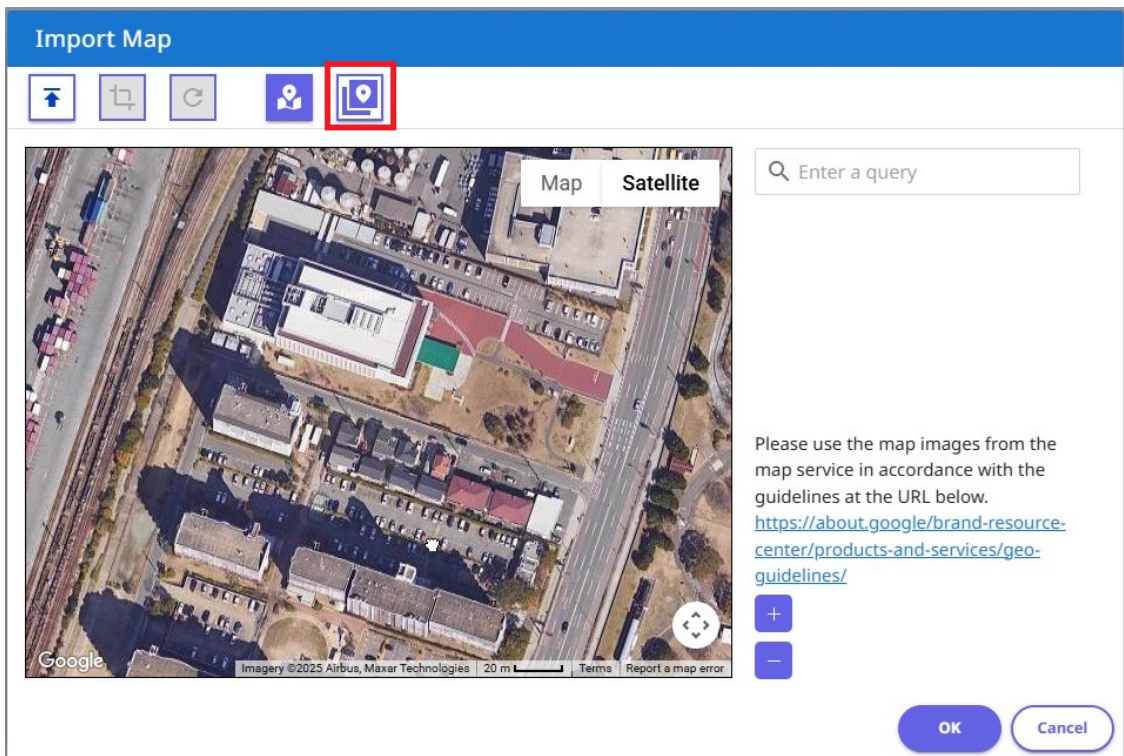

The map image obtained separately will be displayed in transparent state (50% transparent default) in the image downloaded by Map Service.

At this time, the two maps are displayed with the scale and positional shift.

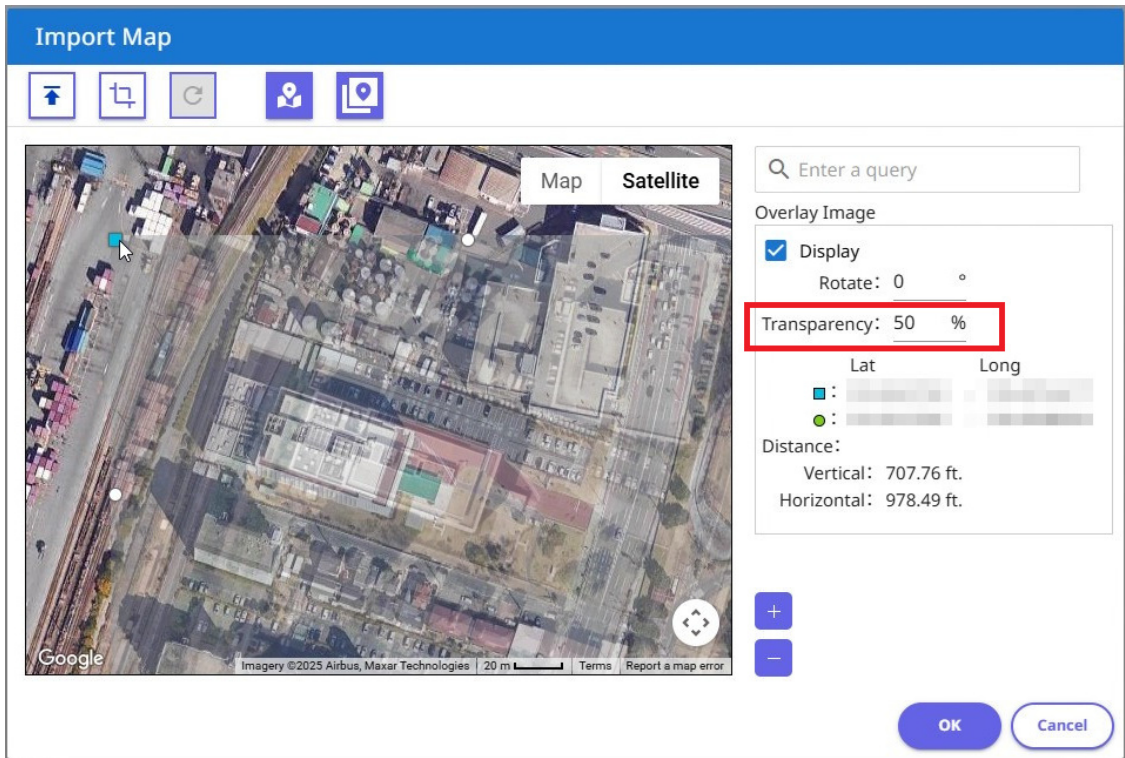

2.9.2.2 Matching Map Service Images with Overlay Images

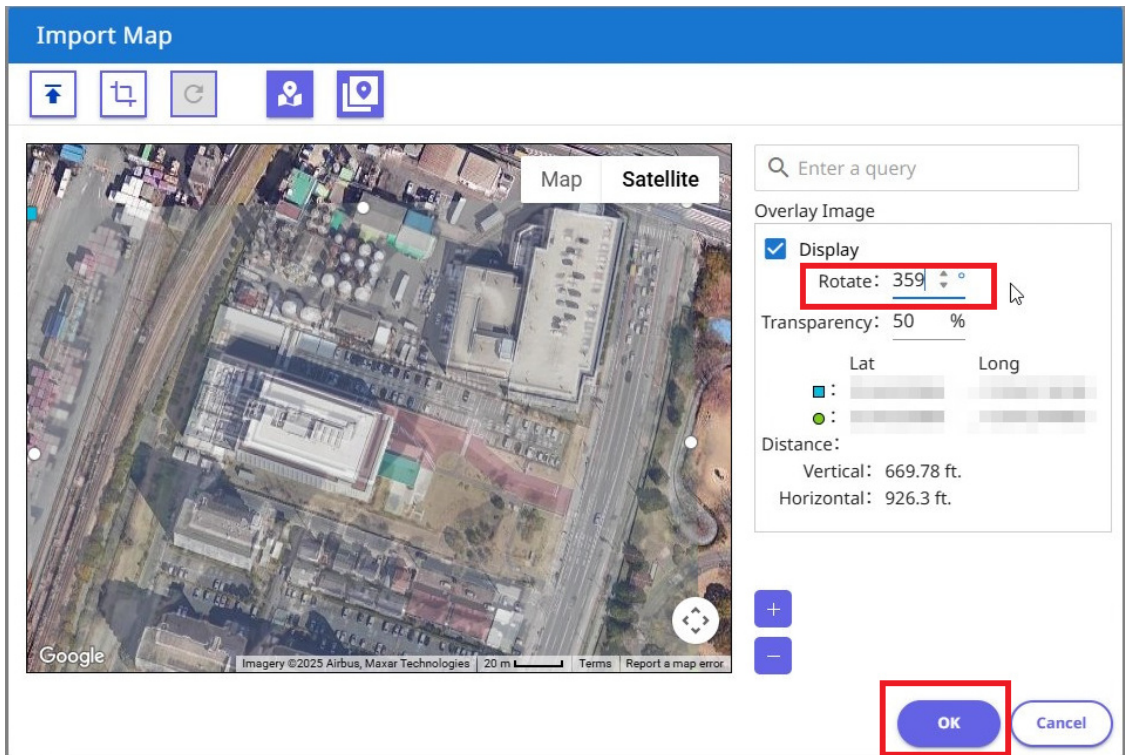

Adjust the position and size of the overlay image on the screen, enter the rotation angle, and fine-tune it.

When alignment is finished, press [OK] to finish importing the maps.

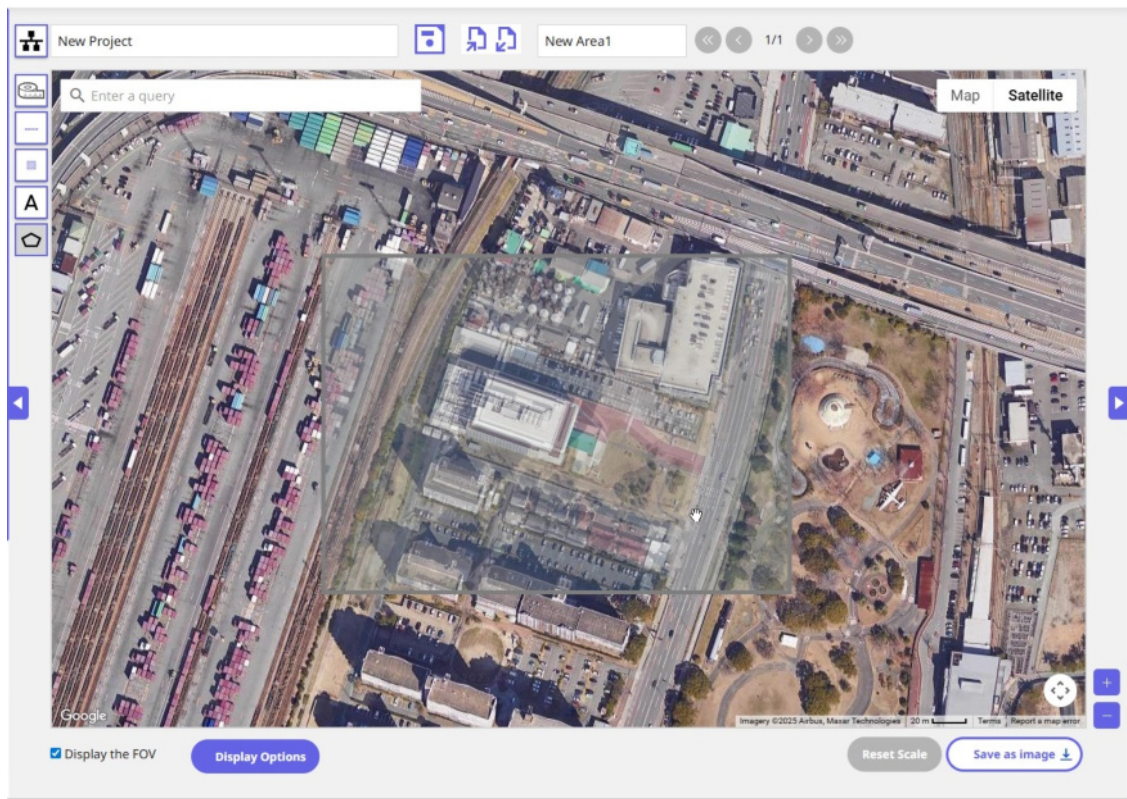

To edit an overlay image after importing it, right-click the image and click [Edit] on the displayed menu. The image can be edited.

To exit, right-click and then click [End] from the displayed menu. The editing is completed.

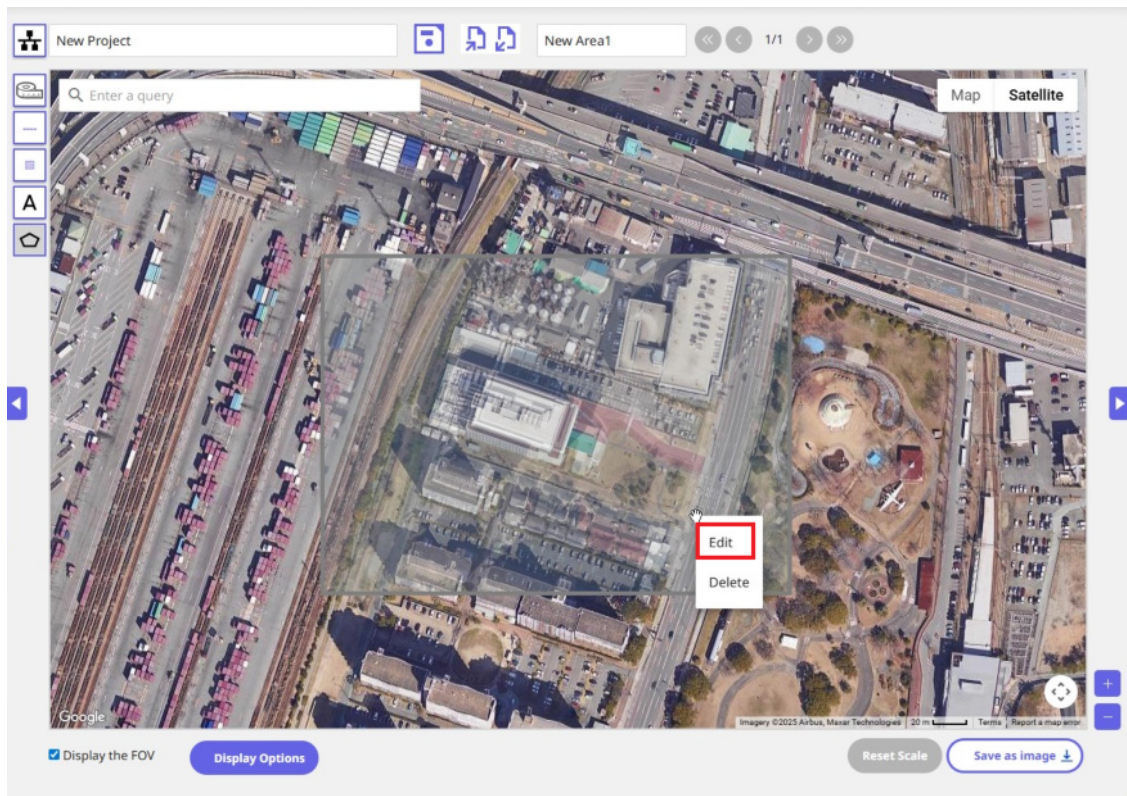

2.9.3 Exporting Files

File export is required to work with i-PRO Configuration Tool. For the operation procedure, refer to "2.7 Exporting Project Files".

3. Preparing for i-PRO Configuration Tool

3.1 Getting and Installing the i-PRO Configuration Tool

i-PRO Configuration Tool is a tool for collectively managing the settings and maintenance of the devices of the video monitoring system in the entire system. You can change the settings while checking the camera image, and automatically output the report of the settings results.

Please install i-PRO Configuration Tool on your PC by downloading it from the address below.

https://i-pro.com/products_and_solutions/en/surveillance/learning-and-support/tools/ict/ict-pal

Home / Surveillance / Learning and Support / Tools / i-PRO Configuration Tool (iCT)

i-PRO Configuration Tool (iCT)

Overview

i-PRO Configuration Tool is designed to efficiently configure the settings and maintenance of up to 1,024 i-PRO devices(network cameras, disk recorders, etc.) through a personal computer via a network.

Key Features

- Camera batch settings for up to 1,024 multiple cameras
- Camera advanced settings with image stream viewing screen
- AI extension software batch installation and advanced settings
- Generation of devices settings report with camera view images
- Collective maintenance of devices, including automatic firmware updates

File information

Document type:	Tools	
File Size:	378MB	
File Format:	ZIP	
Version:		
Modified Date:		

[DOWNLOAD](#)

- When using i-PRO Configuration Tool with this unit, be sure to use the V4.60 or later software.
- Download the i-PRO Configuration Tool file to your PC and extract the file. This is installed by replacing (or copying) the "i-PRO_Configuration_tool_Vx.xx" file in the extracted folder with the file, or by double-clicking the Setup.exe file in the "i-PRO_Configuration_tool_Vx.xx" Refer to

the "Operating Instructions" on the same Web for the startup procedure.

3.2 Verifying Hardware Environment Connectivity

This is an example of the connection environment when using this machine. Refer to the Installation Manual for the installation procedure of this machine.

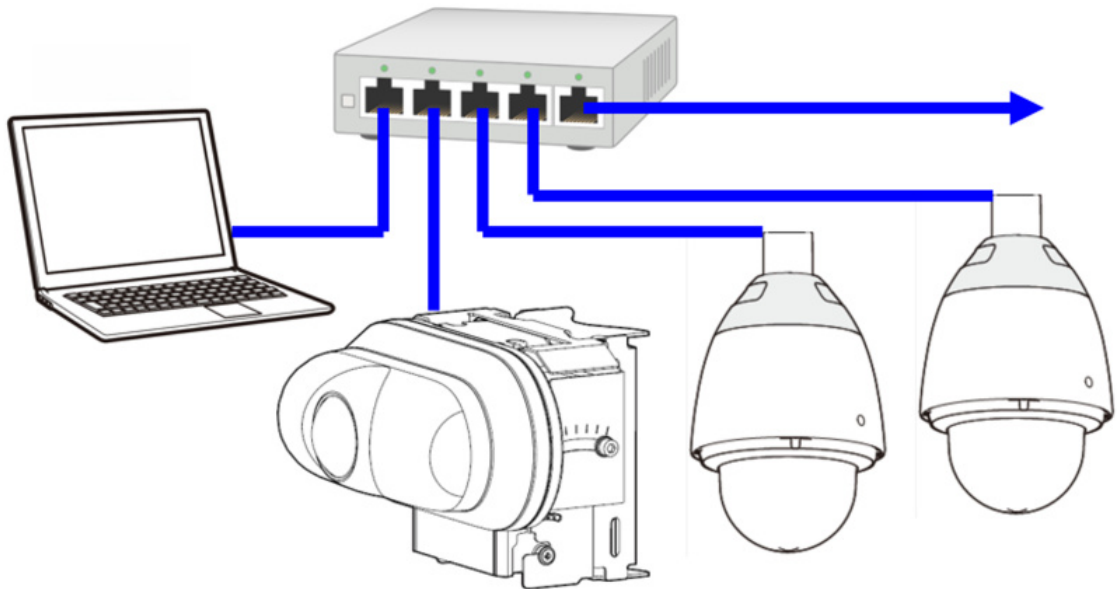

3.3 Starting the i-PRO Configuration Tool

If it is used for the first time after i-PRO Configuration Tool is installed, set the username and password. From the second time, the following window appears. Enter your username and password. Then, press [Log in].

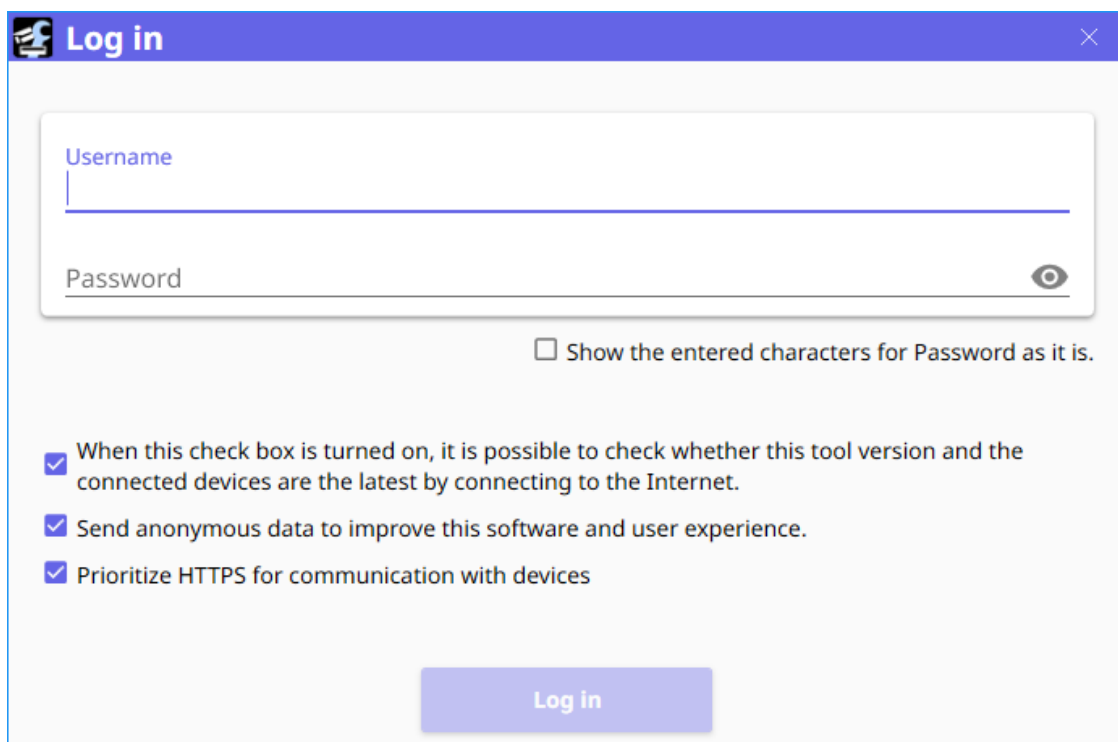

Choose Professional Mode and choose [Next].

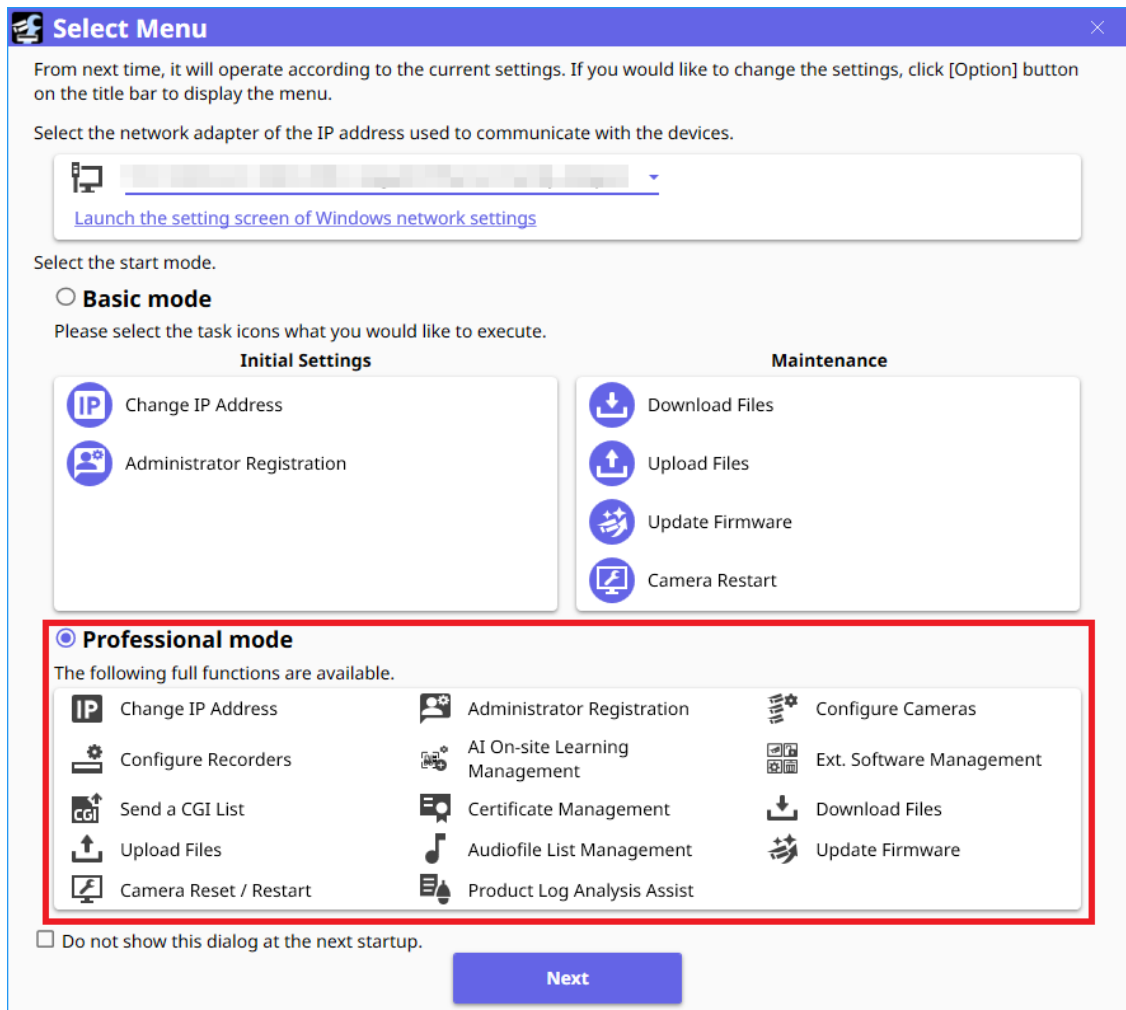

The i-PRO Configuration Tool window appears.

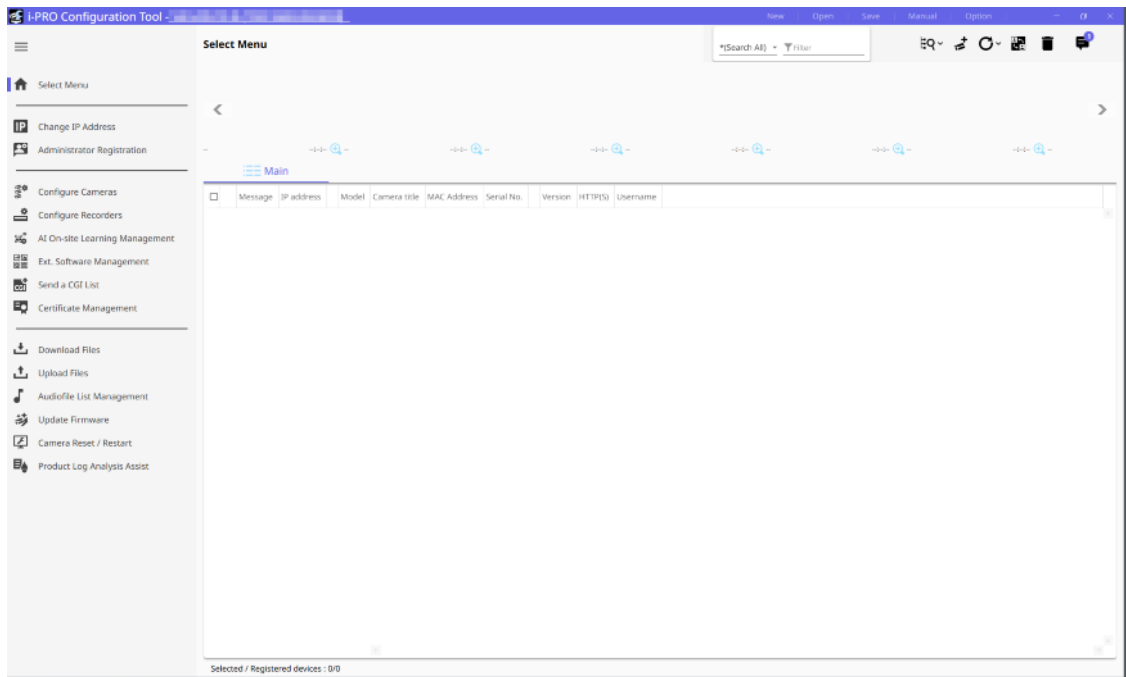

Clicking [Automatic Device Detection] in the upper left corner of the screen displays the following two detection methods. Select it according to the required discovery range.

- To detect devices in the same network segment automatically.
- To detect devices automatically by specifying IP address range.

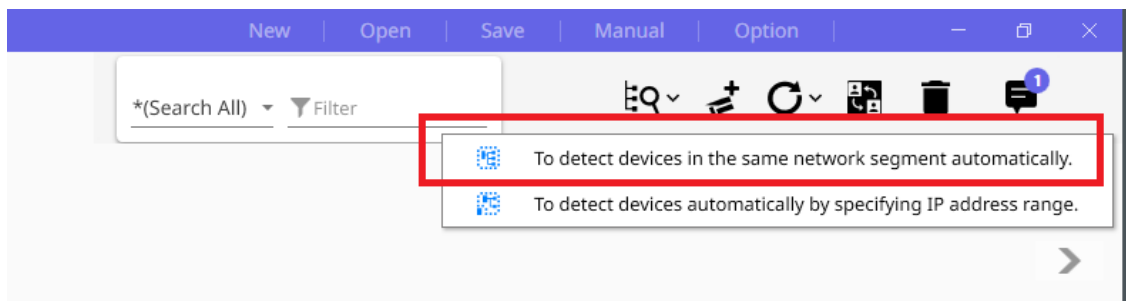

The following detection result screen is displayed. (In this case, you can see that the Security Radars and PTZ camera are connected to the system.)

The following devices were newly detected.
Please get the further setting information of the target devices by [Start] button.

IP address	Model	Camera title	MAC Address	Serial No.	Version	HTTP(S)
192.168.0.15	RD5500-CE	Radar_F	D4-2D-C5-83-D7-48	YJA07932	1.00	80
192.168.0.14	RD5500-C	Radar_E	D4-2D-C5-07-19-CC	XDA08846	1.00	80
192.168.0.13	RD5500-C	Radar_D	D4-2D-C5-83-D7-47	YJA07931	1.00	80
192.168.0.153	GA-AS10TPoE+		00-50-40-4D-1F-33		1.0.0.14	80
192.168.0.20	X66300-Z4L	WV-X66300-Z4L	D4-2D-C5-21-F8-3A	WGV08812	3.65	80
192.168.0.11	RD5500-C	Radar_B	D4-2D-C5-07-19-EB	XDA08877	1.00	80
192.168.0.212	M24PWR		00-C0-8F-0E-EE-22		2.0.7.01	80
192.168.0.16	RD5500-C	Radar_G	D4-2D-C5-83-D7-44	YJA07928	1.00	80
192.168.0.10	RD5500-C	Radar_A	00-80-45-0D-00-02	IAA00001	1.00	80
192.168.0.12	RD5500-C	Radar_C	D4-2D-C5-83-D7-5F	YJA07955	1.00	80

Total : 10

Input Username and Password to access the devices.

Camera
Username
Password

Recorder
Username
Password

Others
Username
Password

Show the entered characters for Password as it is.
 Use this settings at next time

Start



Important

- The [Username] and [Password] for logging in to the Security Radar and PTZ cameras must be the same in advance.

Clicking [Start] confirms accessing the device. If there is no problem, the message "Completed" is displayed on the screen.

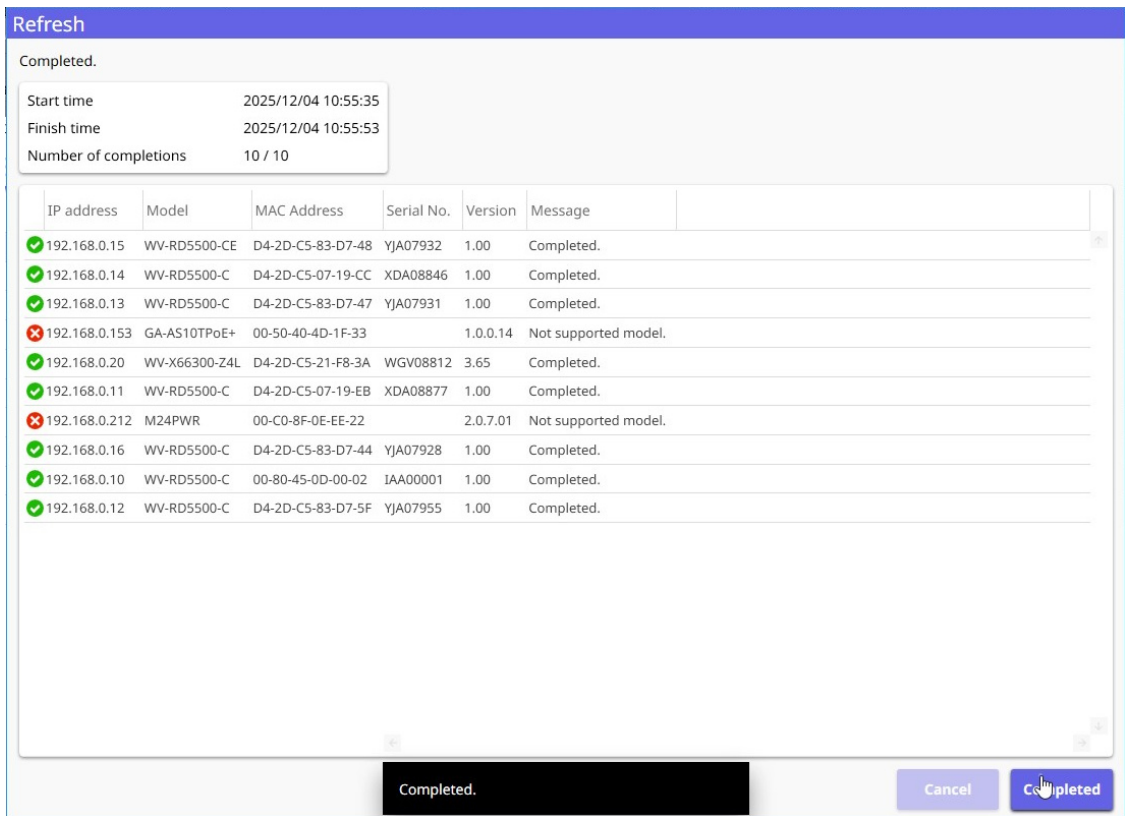

When [Complete] is clicked, the device connected to the system is displayed in the first i-PRO Configuration Tool window.

i-PRO Configuration Tool window

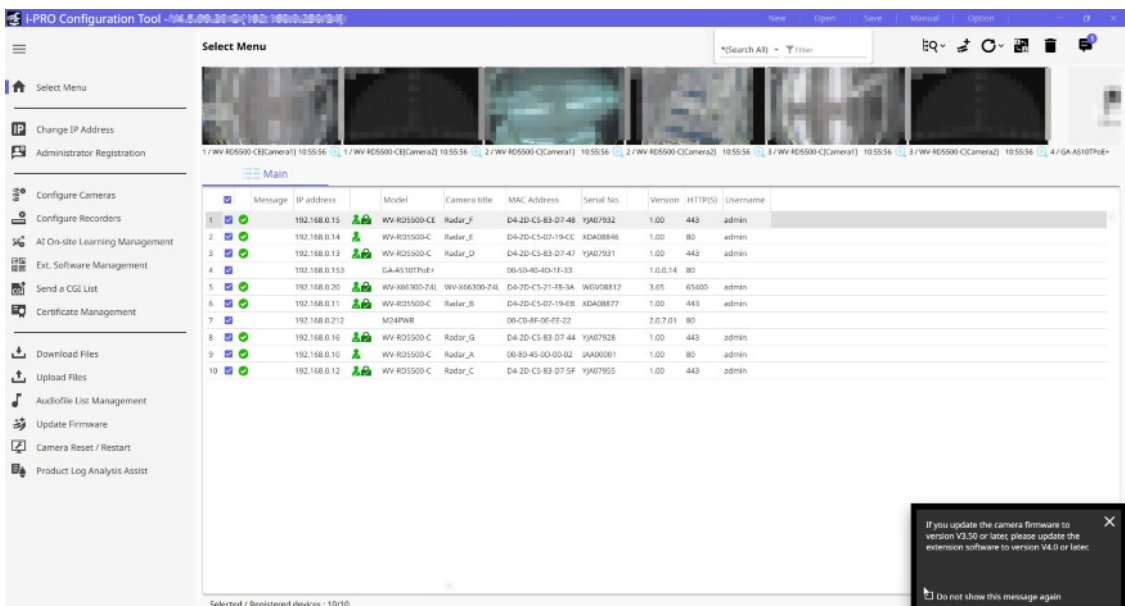

4. Radio interference avoidance

If more than one Security Radar is installed within a certain area, transmitting at the same time in the same frequency band may cause interferences, resulting in false positives or reduced accuracy of detection.

This is because the overlapping of the signals of each radar prevents accurate detection. In particular, Security Radar installed in the 250m are likely to interfere with each other.

Therefore, it is necessary to set the channels that shift the transmission timing of the Security Radar. You can configure up to six Security Radar channels to avoid interference in the same wired-connected network.

The i-PRO Configuration Tool automatically checks for interference between Security Radar and automatically assigns the best channels to avoid interference efficiently.

There are several ways to avoid radar interference:

- Automatic channel-setting to Security Radar

The channel is automatically assigned to the actual radar based on the simulation results of the system design tool. A project file with the radar IP address is required.

- Pre-Simulation Results with System Design Tool

Based on the simulation results of the system design tool, it is possible to check in advance whether the number of channels is 6 or less. This is useful when designing because communication with the actual machine is not required.

4.1 Procedures for radio interference avoidance

The procedure for avoiding radar interference is as follows:

1. Start i-PRO Configuration Tool and discover the networked Security Radar.
2. Place the cursor on Security Radar and right-click to select [Radio Interference Avoidance].

This displays a screen like the one shown below.

Main											
	Message	IP address		Model	Camera title	MAC Address	Serial No.		Version	HTTP(S)	Username
1	✓	192.168.0.15	👤	WV-RD5500-CE	Radar_F	D4-2D-C5-83-D7-48	VIA07022		1.00	80	admin
2	✓	192.168.0.14	👤	WV-RD5500-C	Radar_E	D4-2D-C5-07-					
3	✓	192.168.0.13	👤	WV-RD5500-C	Radar_D	D4-2D-C5-83-					
4	✓	192.168.0.16	👤	WV-RD5500-C	Radar_G	D4-2D-C5-83-					
5	✓	192.168.0.10	👤	WV-RD5500-C	Radar_A	00-80-45-0D-0					
6	✓	192.168.0.11	👤	WV-RD5500-C	Radar_B	D4-2D-C5-07-					
7	✓	192.168.0.12	👤	WV-RD5500-C	Radar_C	D4-2D-C5-83-					

To access the target device via Web browser.

Enlarged screen display

Security Radar Calibration Settings

Radio Interference Avoidance

Radio Interference Avoidance ✕

Configuration Method

Automatic Channel Assignment to Security Radar

Pre-Simulation with System Design Tool
Use Result

Execute

No	Camera Title	IP Address	X Coordinate [m]	Y Coordinate [m]	Channel	Message

- For "Automatic Channel Assignment to Security Radar"

Click the [Execute] button on the radio interference avoidance screen.

If six or fewer radars are connected, channels 1 to 6 are automatically assigned to each radar in order, and the following screen is displayed.

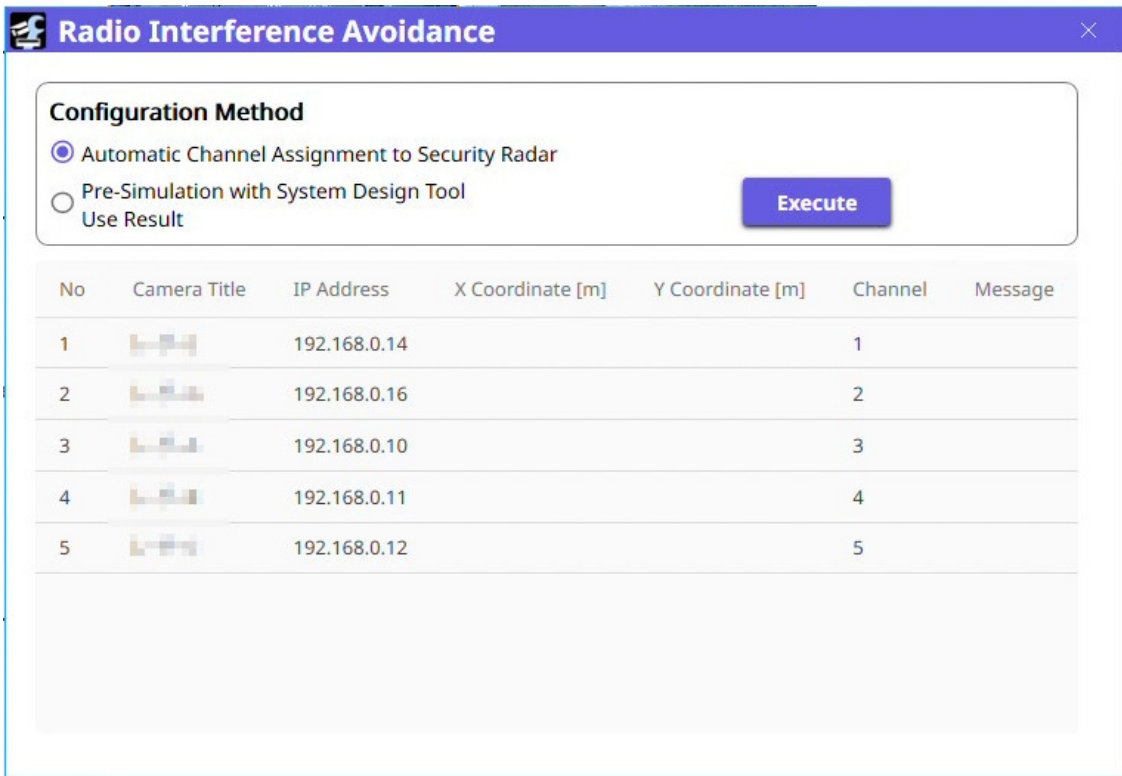

When seven or more radars are detected, the optimum channels are automatically assigned to check the distance between radars and interference conditions based on the simulation results of the system design tool to prevent interference.

The file selection window is displayed. Select the project file of the system design tool with the IP address of Security Radar created beforehand. After the selection, the following screen is displayed.



To register a IP address to Security Radar in the system design tool, you can set it from the following window.

– For “Pre-Simulation with System Design Tool”

Click the [Execute] button on the radio interference avoidance screen.

The file selection screen is displayed. Select the project file of the system design tool created beforehand. After the selection, the following screen is displayed.

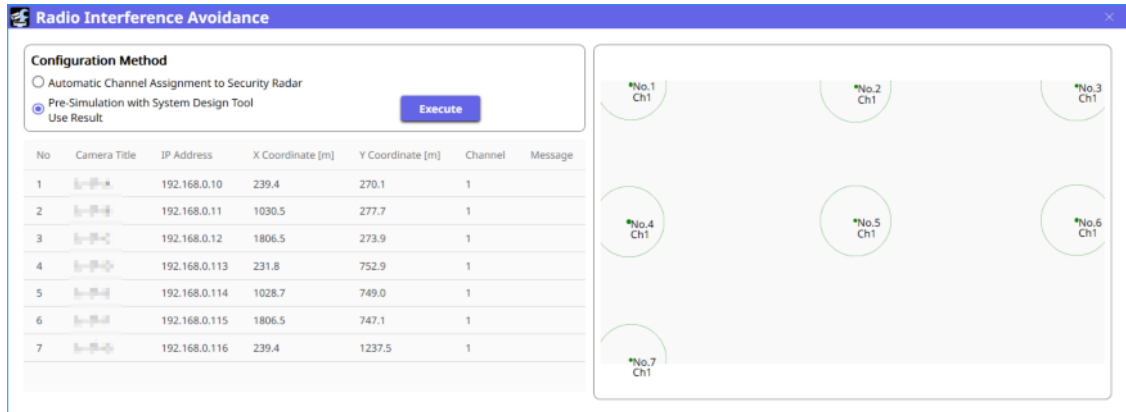

5. Security Radar calibration settings

5.1 To start the calibration screen

Place the cursor on Security Radar, right-click it, and select [Security Radar Calibration Settings]. The [Security Radar Calibration Settings Window] appears.

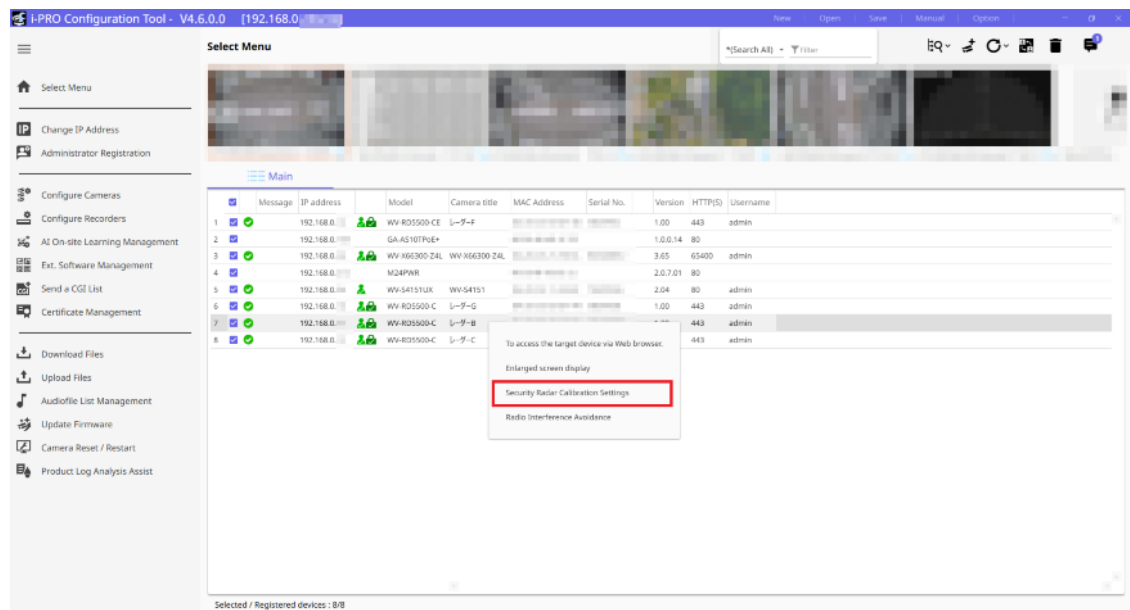

Security Radar Calibration Settings

Configuration Pattern

Map & Camera Position Method Tips

Use a project configured in "System Design Tool"

Project File 📁

Specify map and camera positions on the screen

PTZ Cameras

Link PTZ Cameras

Do Not Link PTZ Cameras

Setup Procedure

- 1 Initial Security Radar Settings**
Perform initial Security Radar setup.
Unit Settings: Meter ⓘ
Set
Next
- 2 System Design Tool Link**
- 3 PTZ Camera Linking**
- 4 Security Radar Calibration**
- 5 PTZ Camera Calibration**
- 6 Latitude/Longitude Settings**
- 7 Alarm Notification Settings**
- 8 Radar Settings (Security Radar)**

5.2 Select the configuration pattern

5.2.1 How to locate the map and camera

If you want to work with the system design tool to capture the location of maps and cameras, select [Use a project configured in "System Design Tool"].

To specify the location of the map and camera directly, select [Specify map and camera positions on the screen].

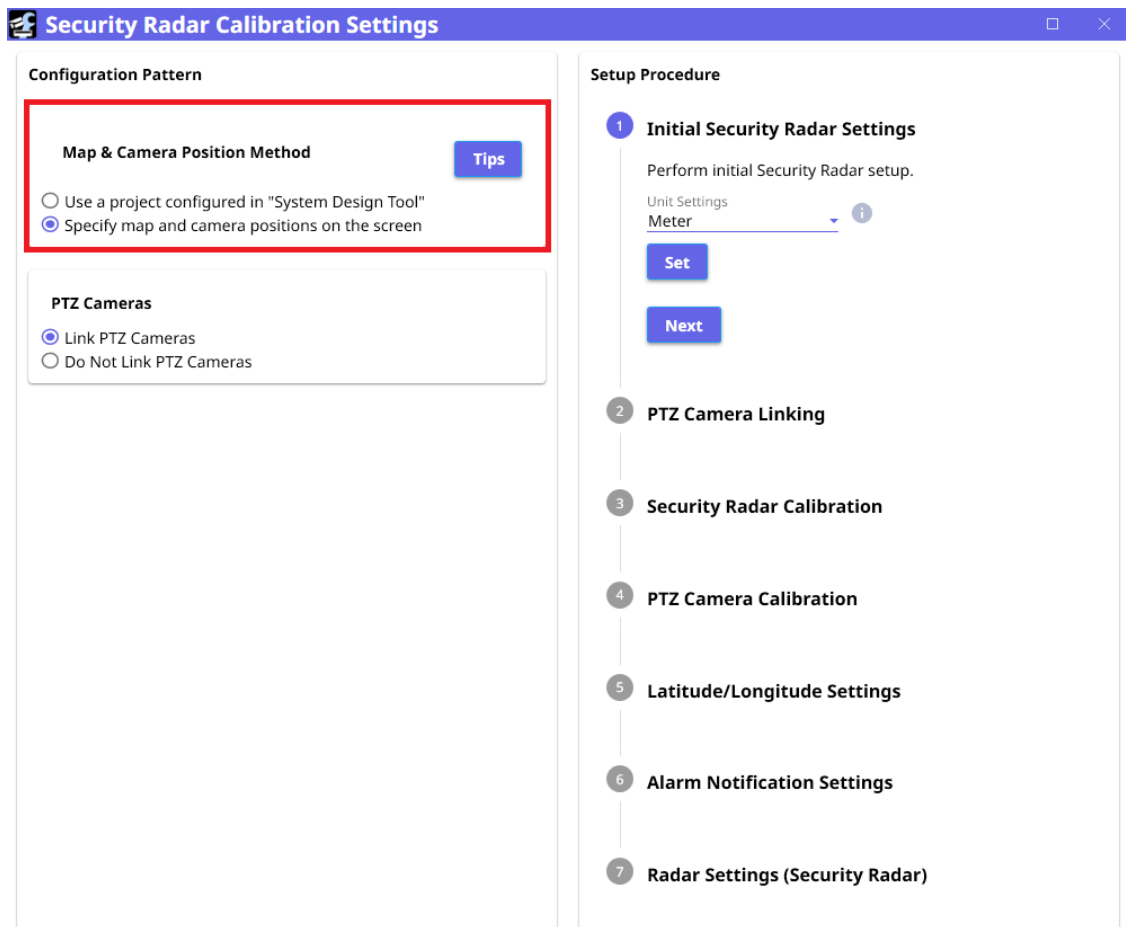

5.2.2 Importing a project file (.sdtproj) created with the system design tool

Select the [Use a project configured in "System Design Tool"].

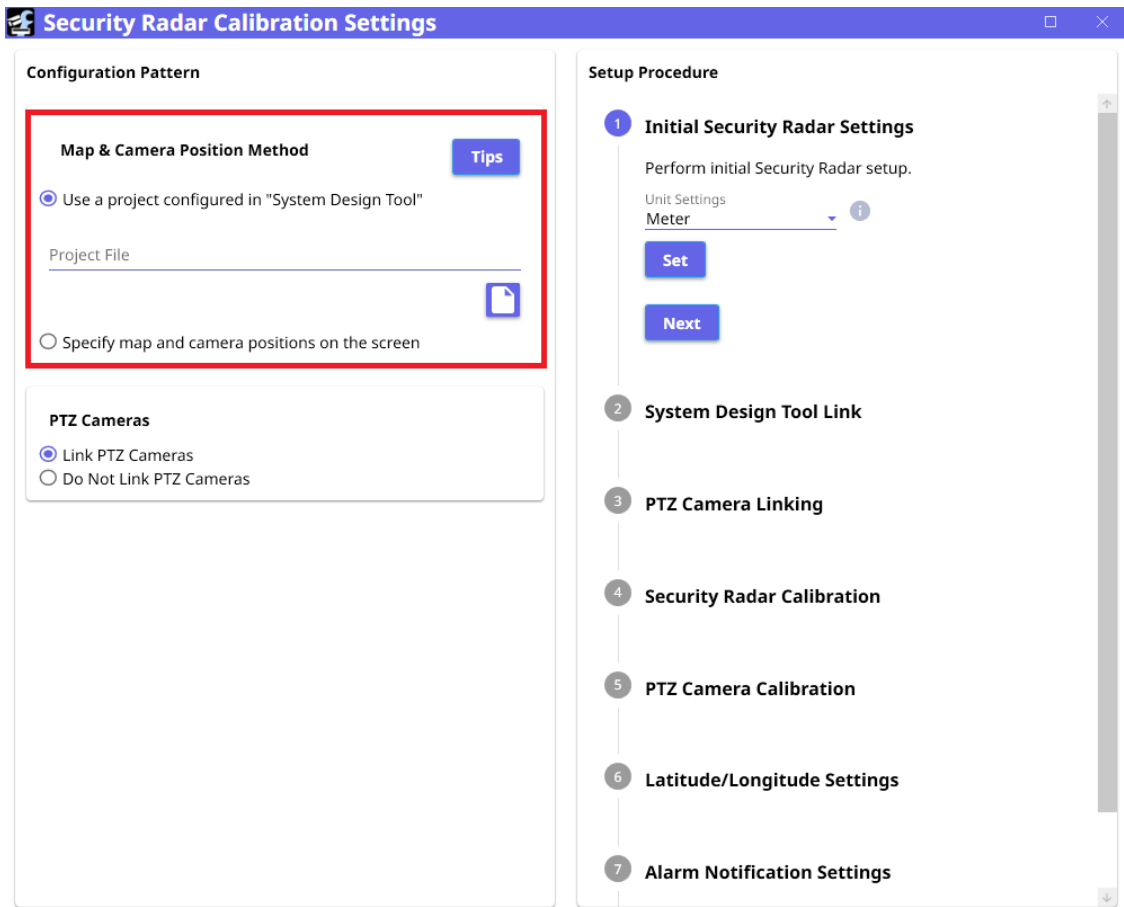

The file selection window opens. Select the desired sdtpj file and select [Open].

When the project file (.sdtpj) has been loaded, "Completed." is displayed. Clicking [OK] returns you to the Security radar calibration settings window.



Important

- If a PIN code is set in the project file (.sdtpj), you need to enter the PIN code. Enter the configured PIN chord.
- If [Use image files from local PC] is enabled, a local save file (.sdtmp) is required. Specify (.sdtmp) that was exported at the same time as the project file (.sdtpj).

5.2.3 PTZ cameras

Select whether or not to link PTZ with Security Radar.

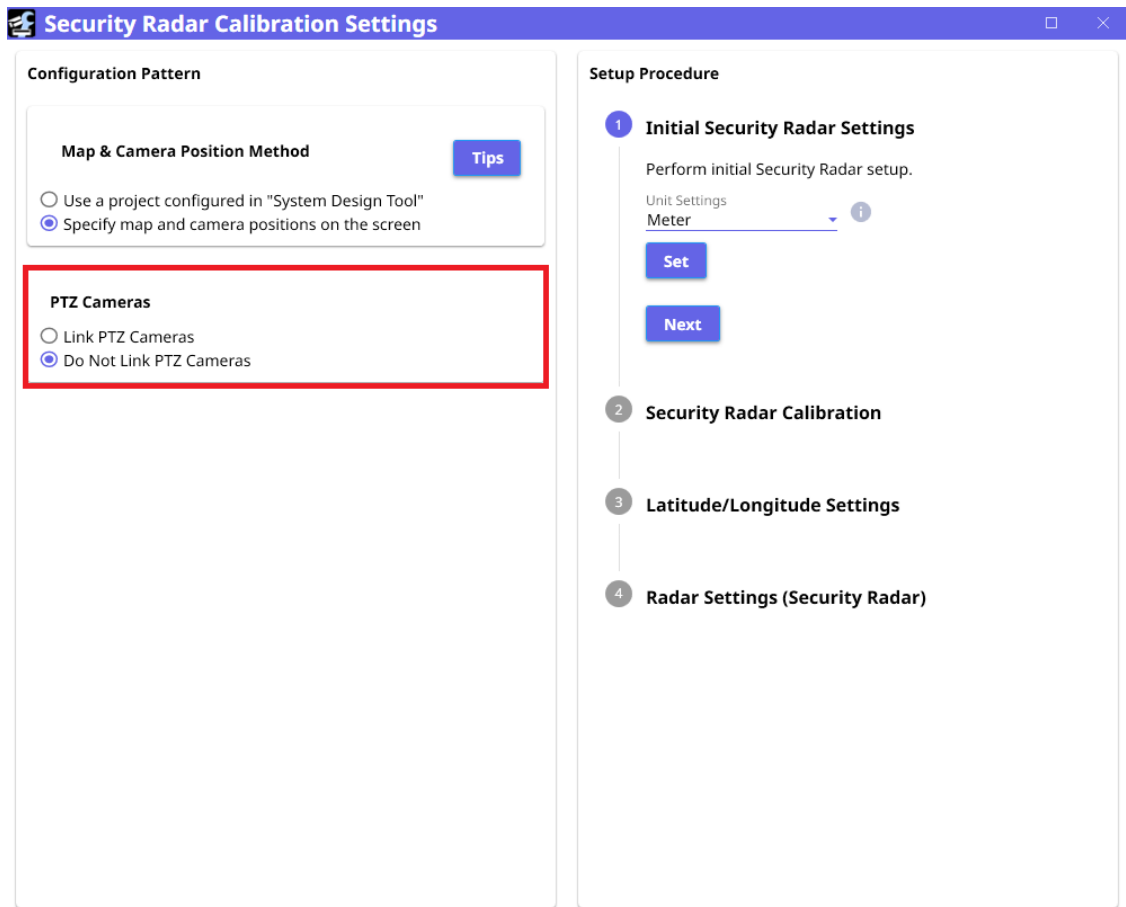

5.3 Initial Security Radar Settings

Select the distance units to be entered in Calibration and press [Set]. After the configuration is complete, press [Next].

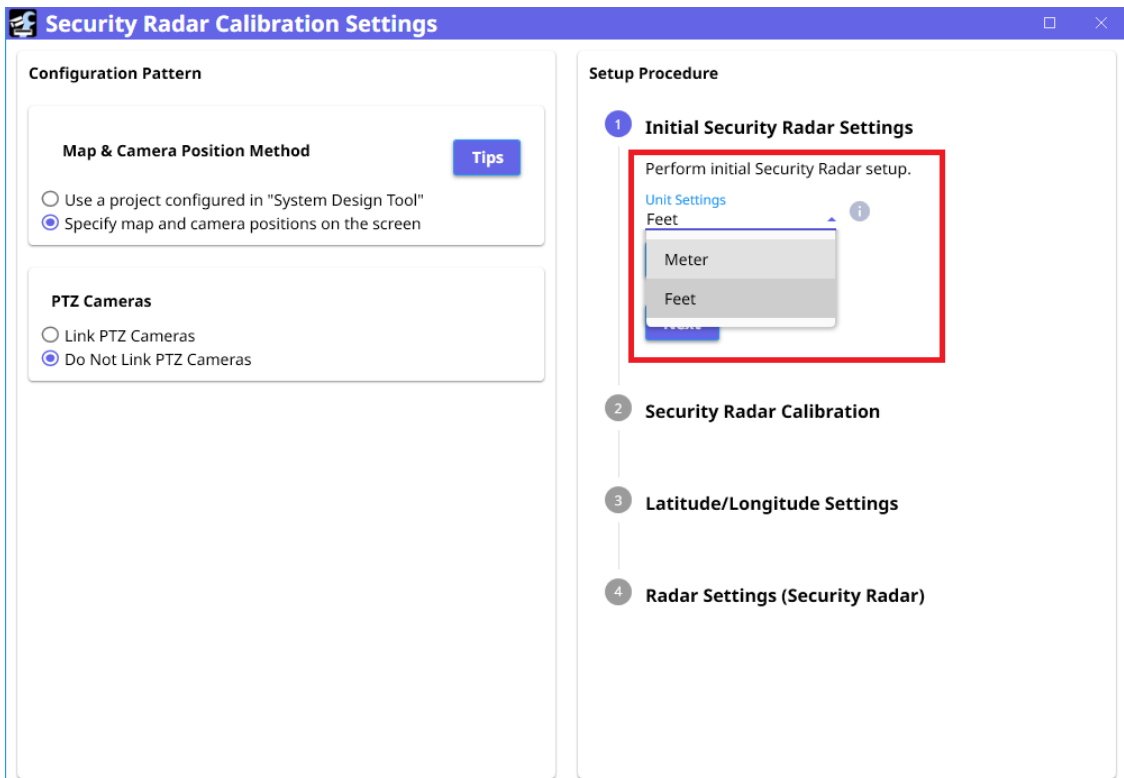

5.4 System design tool link

Select [Execute] in System Design Tool Linkage. Open the [System Design Link] screen to load the project created with the system design tool.

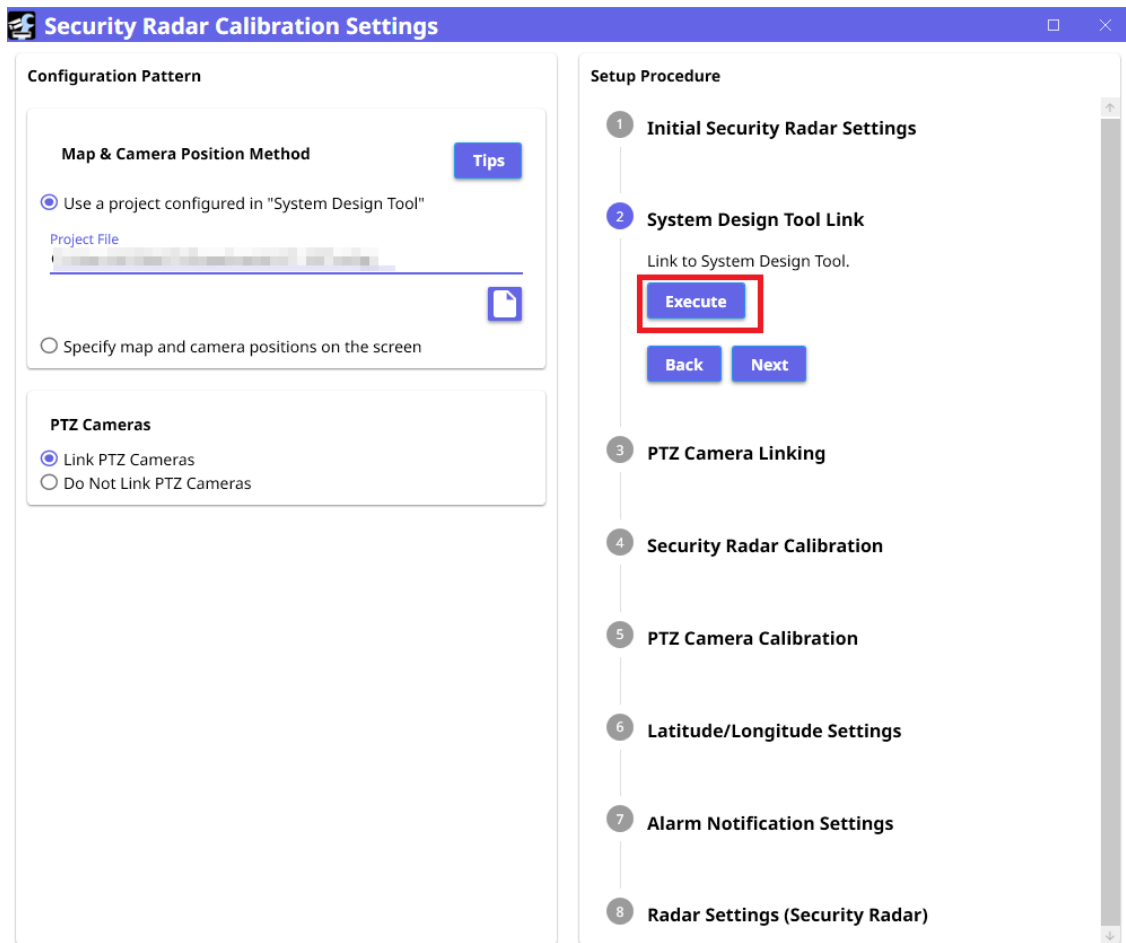

5.4.1 Specifying Area

Select the area you want to import from the areas created with the system design tool, and then select [Next].

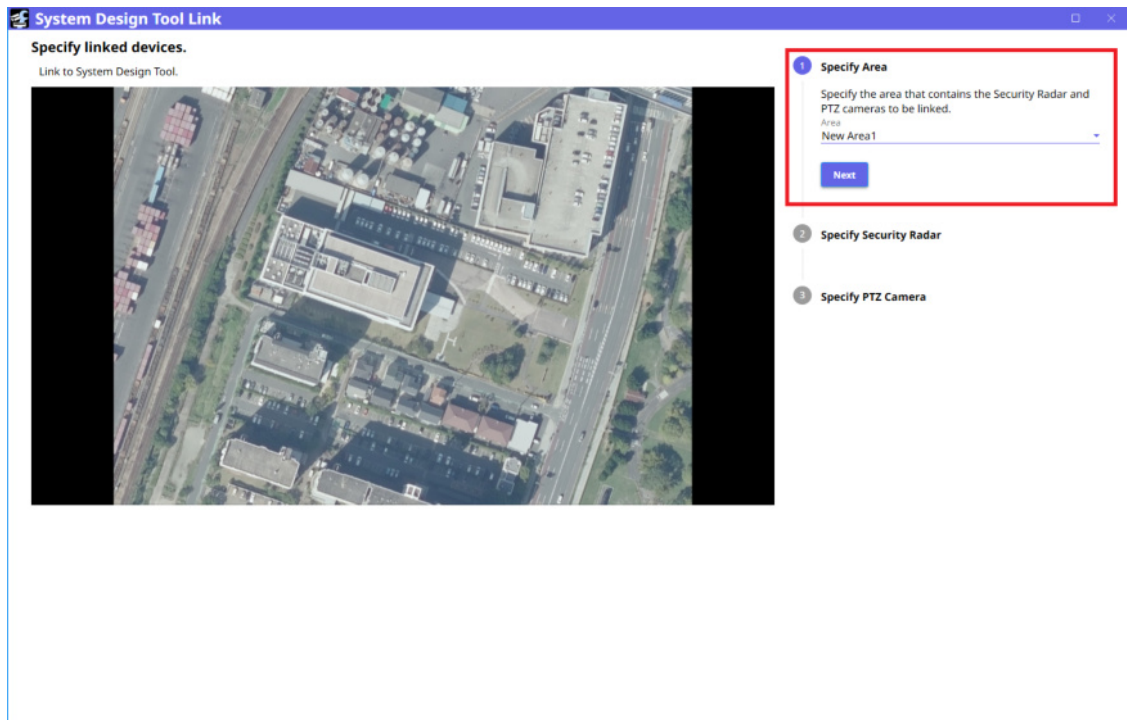

5.4.2 Specifying Security Radar

From the displayed Security Radar, select the [Next] by clicking the icon of the Security Radar for which you want to make calibration settings.

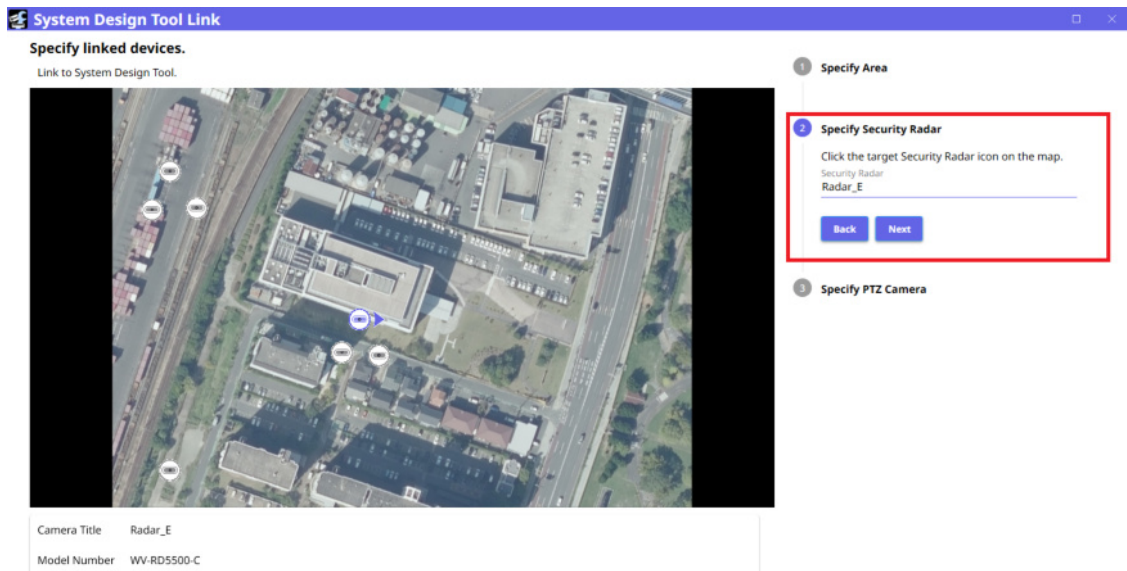

5.4.3 Specifying PTZ camera

From the PTZ cameras that are displayed, click–icon of the PTZ camera that works with the Security Radar.

Up to four PTZ cameras can be linked. Switches the camera number and clicks the icon of the PTZ camera to be linked. Once you have selected everything, press [Set].

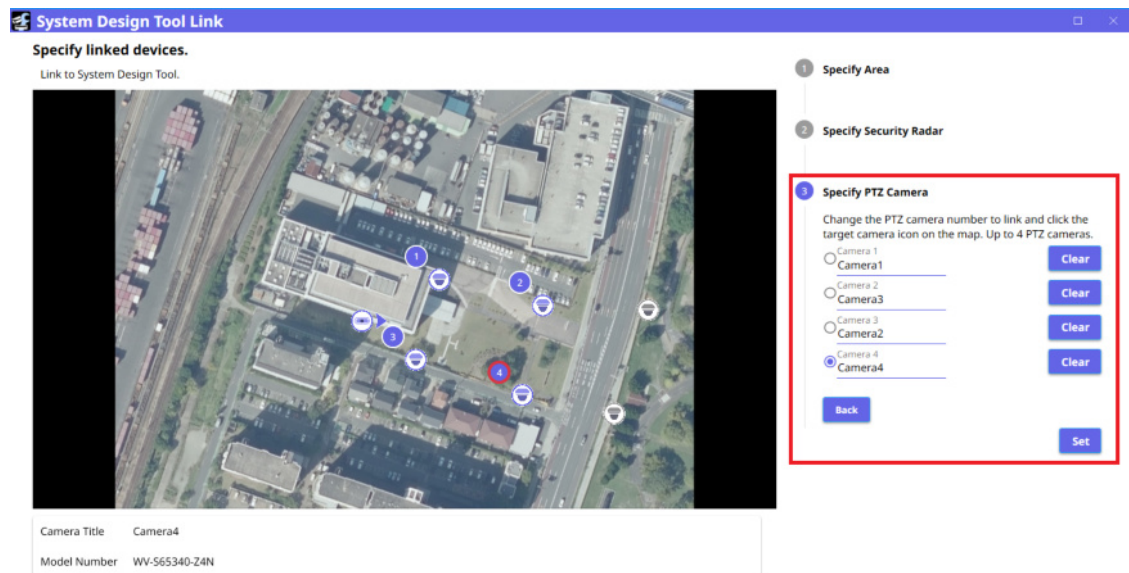

5.5 PTZ Cameras Linking

Clicking [Execute] displays the connected PTZ cameras.

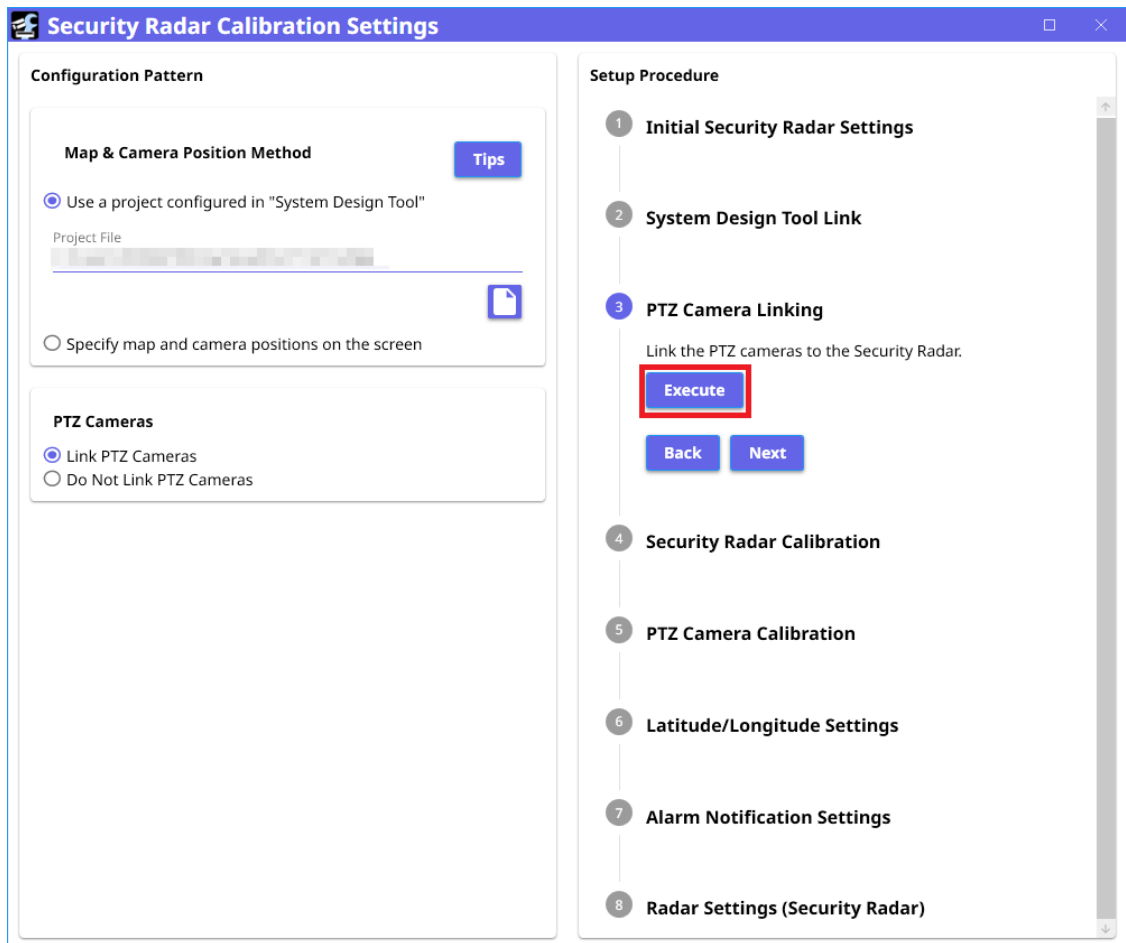

Choose the PTZ cameras to work with your Security Radar and move them by dragging & dropping.

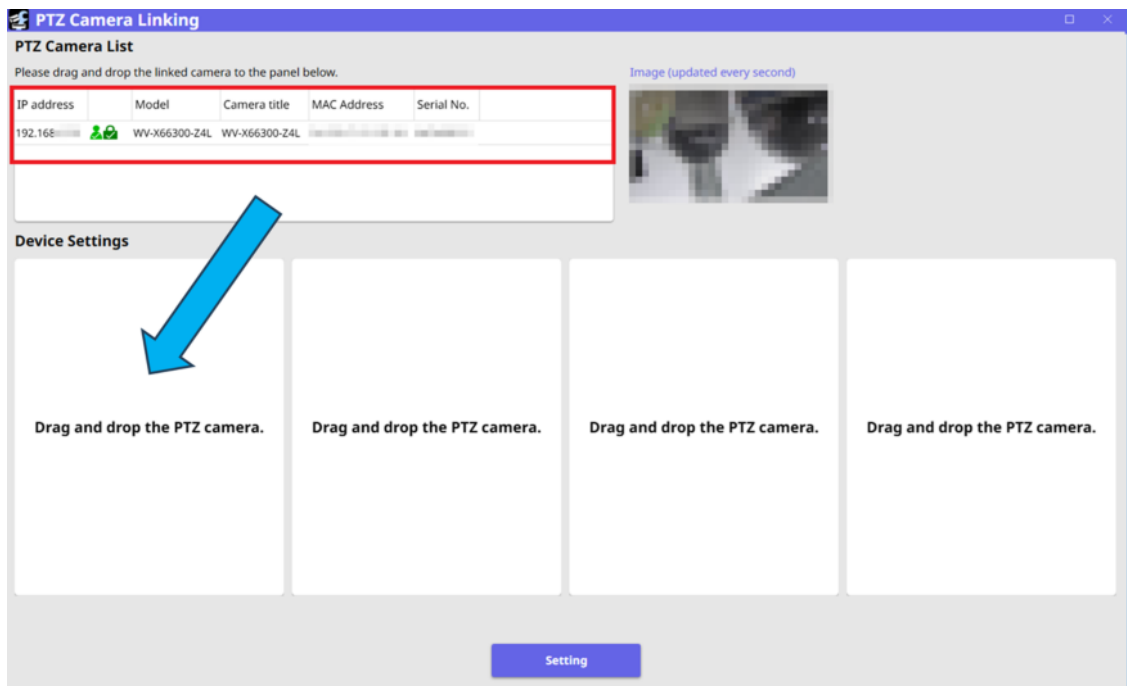

When you are done, press [Setting]. When the communication between the Security Radar and PTZ is confirmed, the [Connection Status] switches to [Connected].

After completing the settings, click [OK] on the confirmation window to close the window.

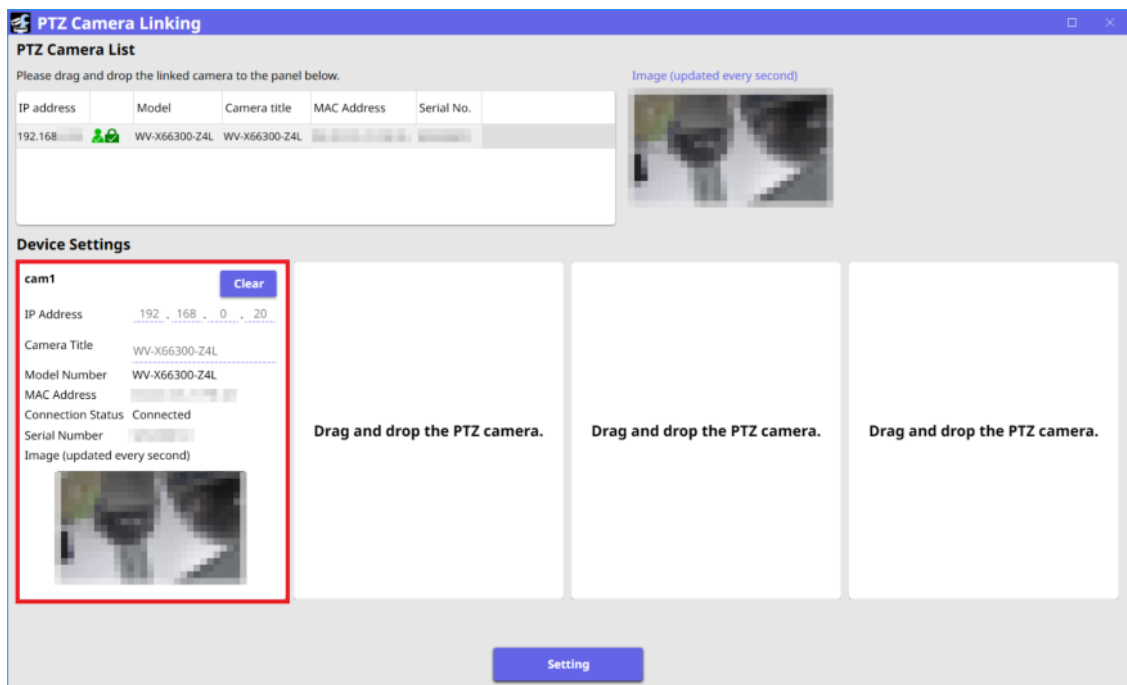

5.6 Calibrating the Security Radar

Security Radar can be calibrated in the following two ways.

Quick Setup

How to manually set the position and orientation of the Security Radar on the map.

<To be used in the following cases>

- In the case of installation in a place where you cannot directly walk, such as in a water channel

Detection-based Setup

How to walk the site as mapped and manually set the position and orientation of the Security Radar from its trajectory.

<To be used in the following cases>

- When you want to install with high accuracy

5.6.1 Quick Setup

Select [Quick Setup] and press [Execute] to open the Map Setup / Scale Calculation window.

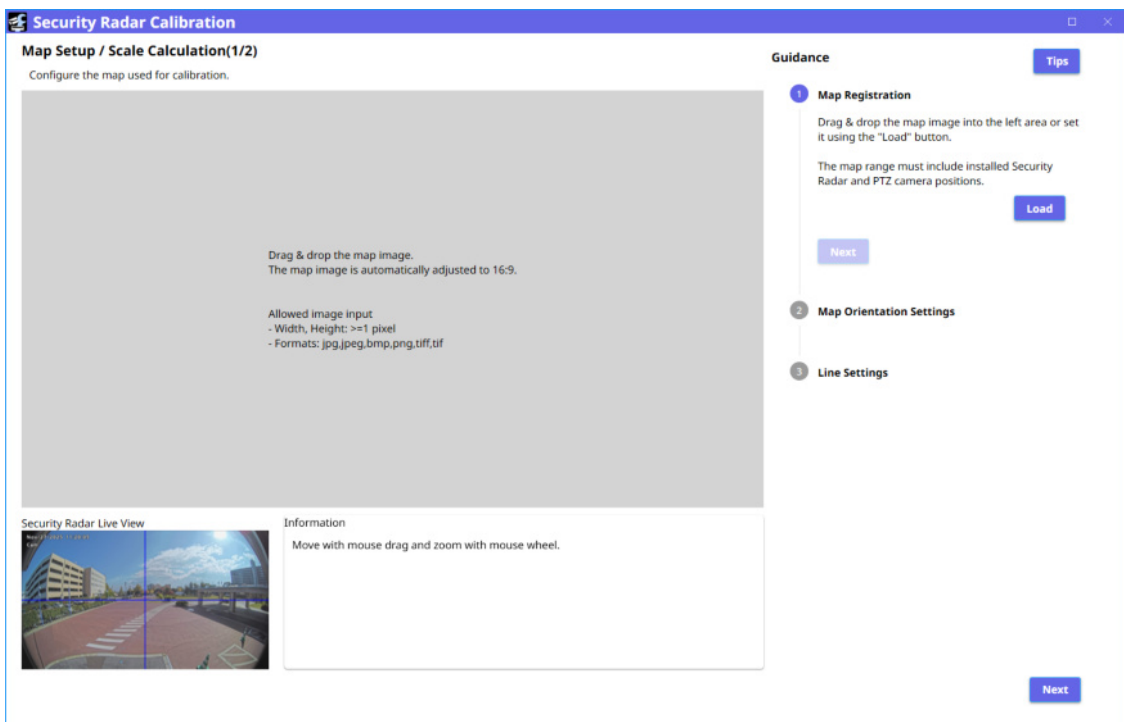
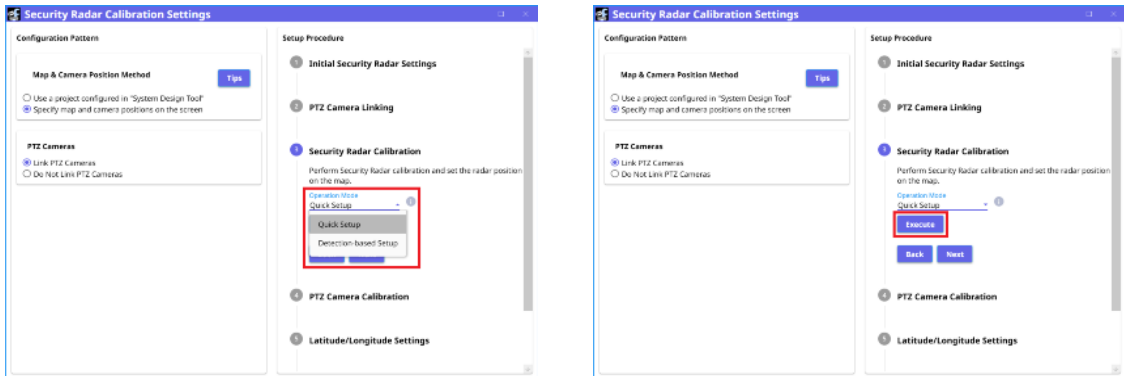

5.6.1.1 Map Registration

Register the map required for calibration. Drag-and-drop the prepared map data on the screen or select the map data from the [Load].

*Map setting is not required when system design tool linkage is performed.

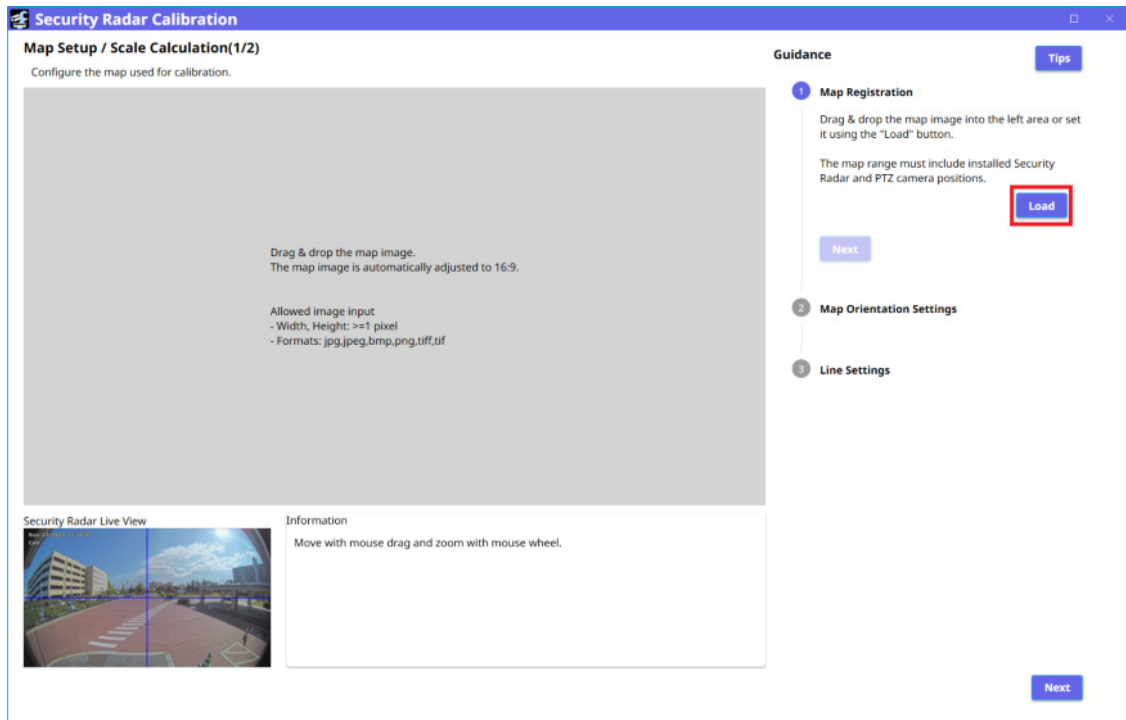

Notice

Maps around the installation site must be prepared by the customer in advance.

After setting up the maps, select [Next].

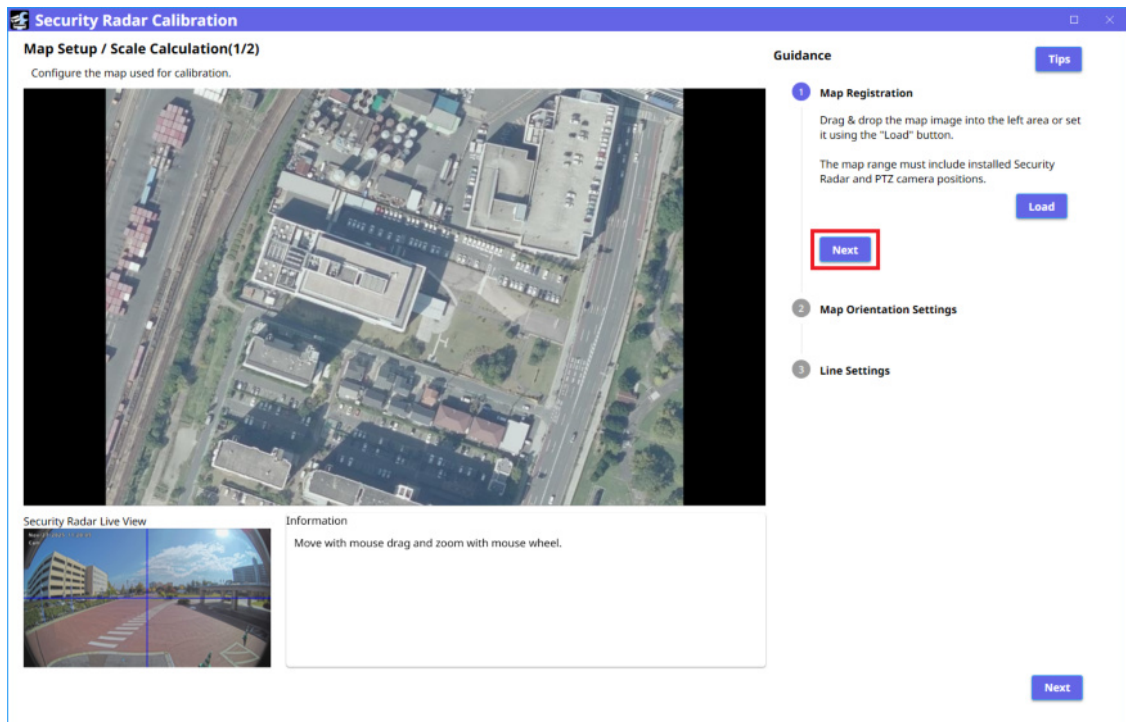

Notice

You can move the imported map by dragging the mouse, and zoom in and out using the mouse wheel.

5.6.1.2 Map Orientation Settings

Align the north direction of the imported map with the north direction of the screen. You can configure the settings in the following ways:

- Rotate the compass on the map by dragging the mouse
- Moving the slider bar
- Numeric entry in the text field next to the slider bar

After setting the direction, press [Next].

*If system design tool linkage is used, the direction setting is not required.

*If you are not outputting to an external system, setting the direction is not necessary.

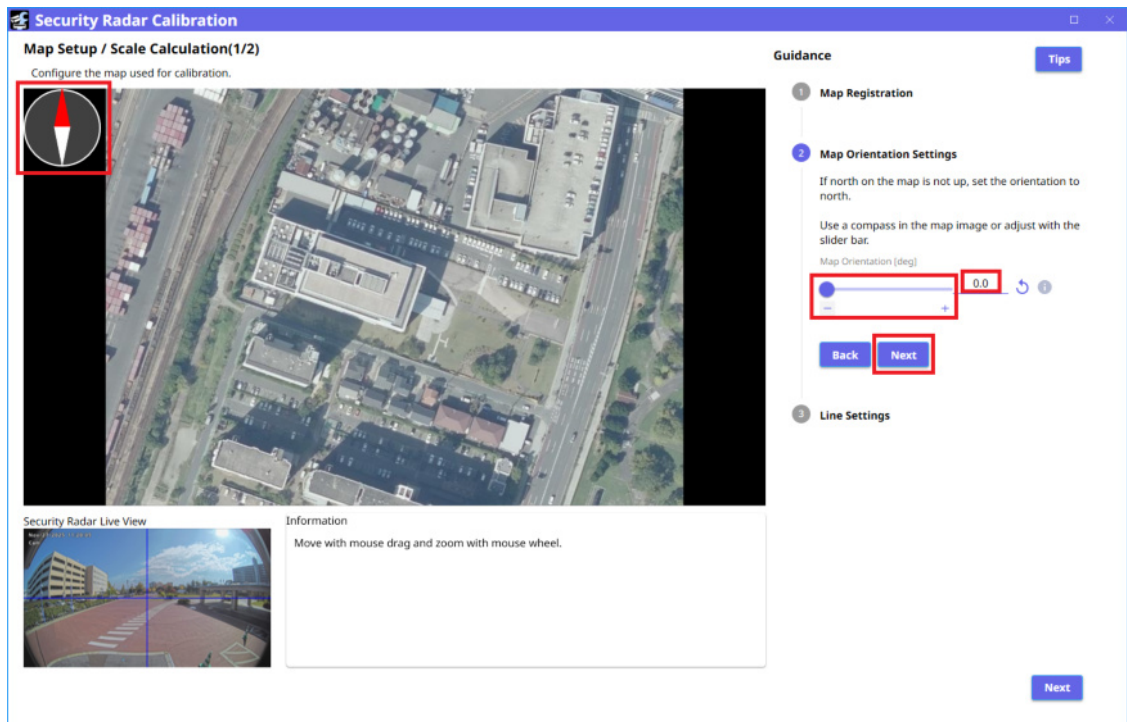

5.6.1.3 Line Settings

Sets the map scale.

*Linear and scale settings are not required when system design tool linkage is used.

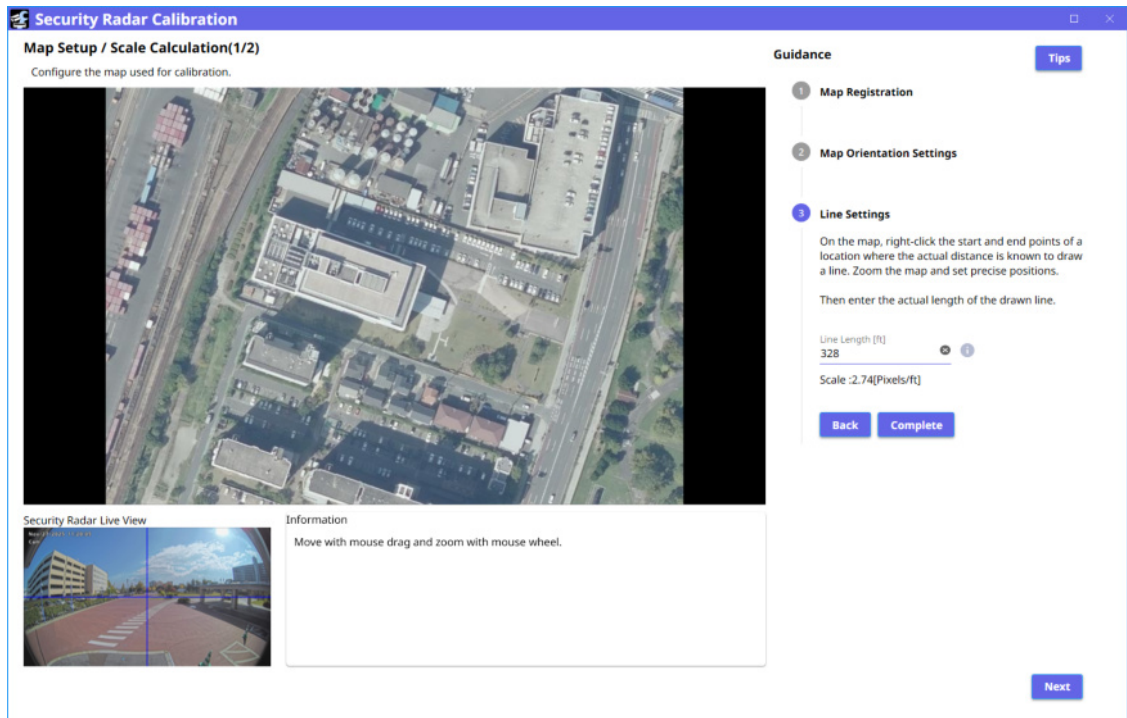

1. Measure the distance between two points on the map.

Measure the distance between two measurable points on the map with a measure, etc. It can be anywhere on maps, but it is preferable to be more than 20m away.

(The following procedure uses the distance between the two yellow circles shown in the illustration as an example.)

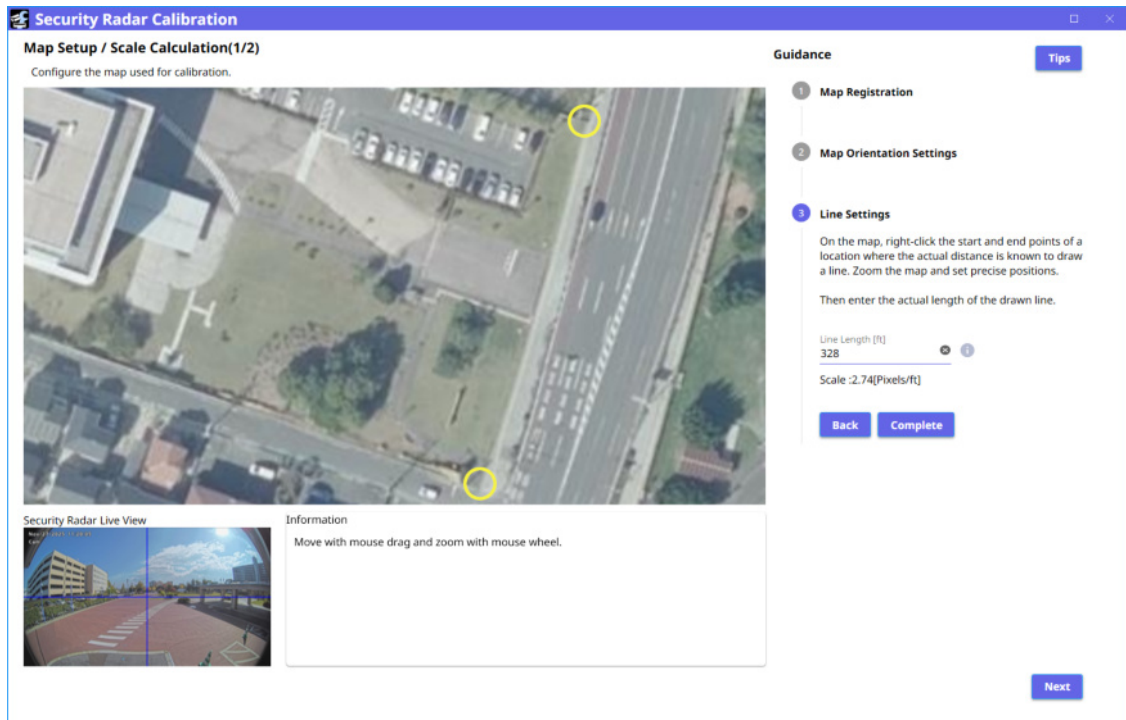

2. Draw a straight line at the measurement point on the map.

Draw the red line from the start point to the end point of the position measured in step 1. Please operate the map data with as much magnification as possible to specify the exact location.

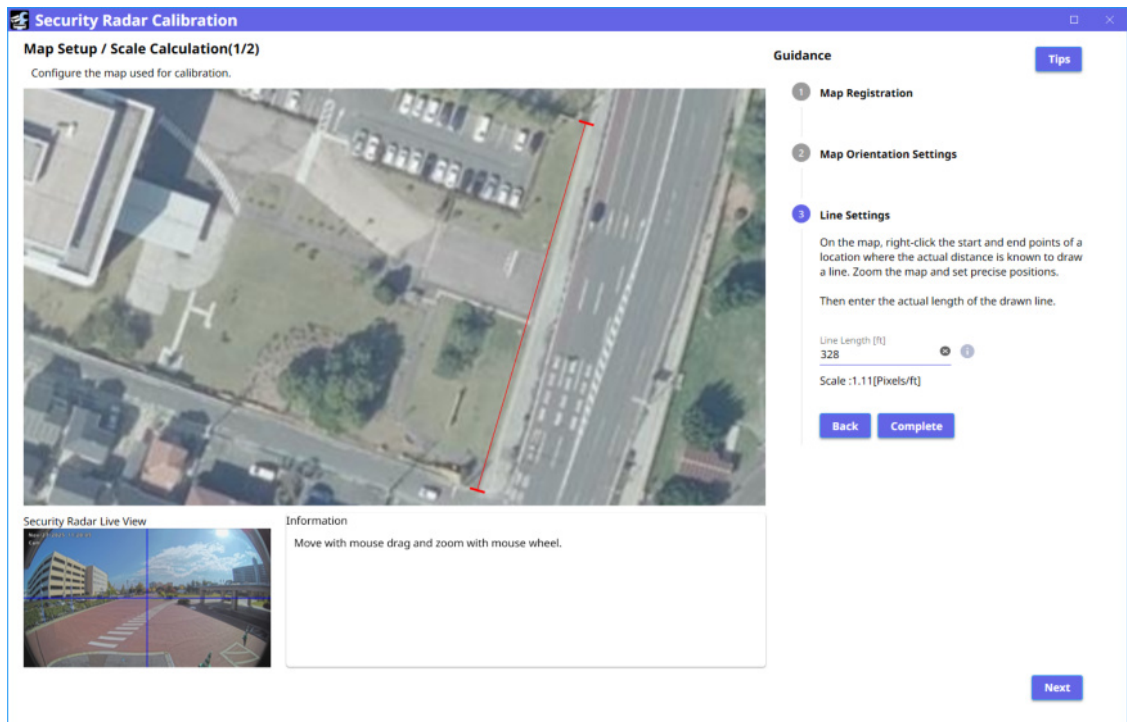

3. Enter the distance between two points to calculate the map scale.

If you enter a distance in [Line Length], the scale is automatically calculated. After typing, press [Complete] or [Next].

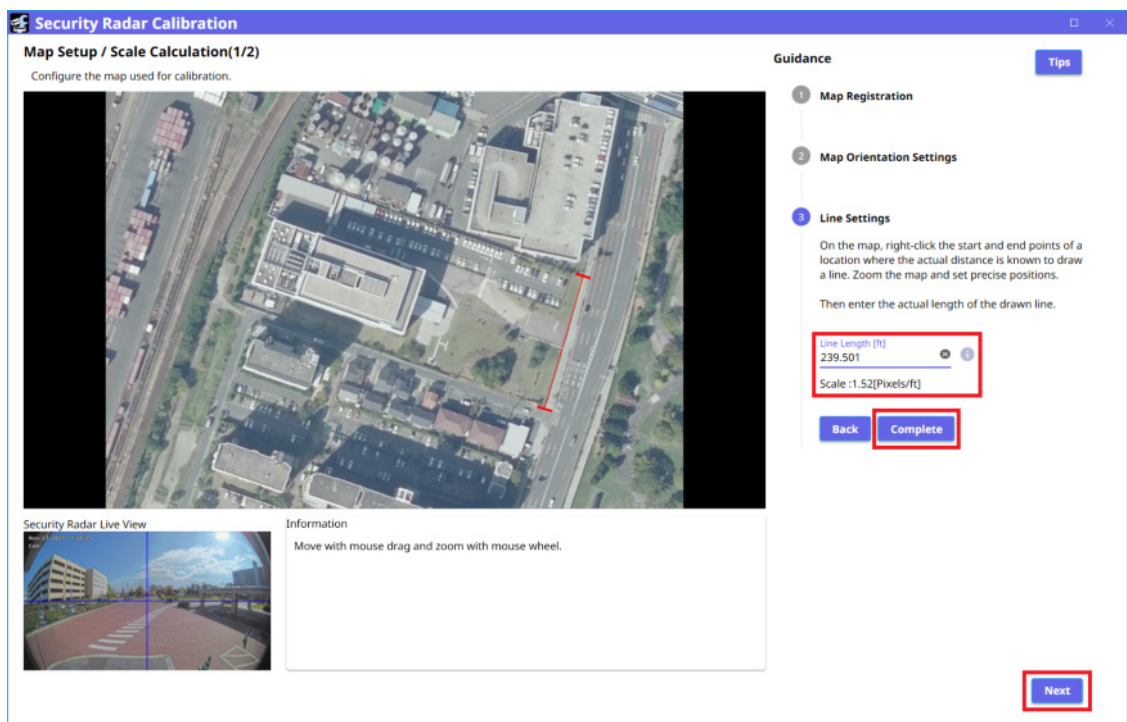

5.6.1.4 Radar Position and Azimuth Settings

Manually set the position and azimuth of the Security Radar.

*If you are working with system design tools, you do not need to set the position and azimuth of the Security Radar.

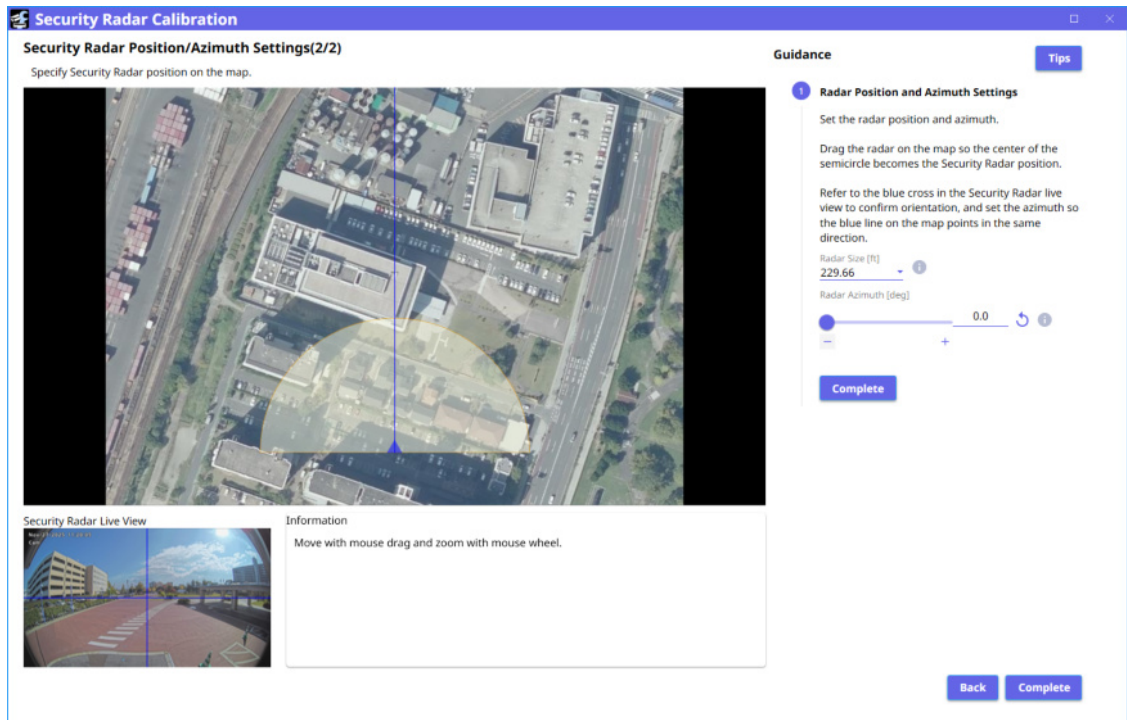

1. Align the Security Radar.

Move the ▲ symbol to the Security Radar position on the map—by dragging the radar area (semicircle). To improve accuracy, use the mouse wheel to enlarge the map as much as possible.

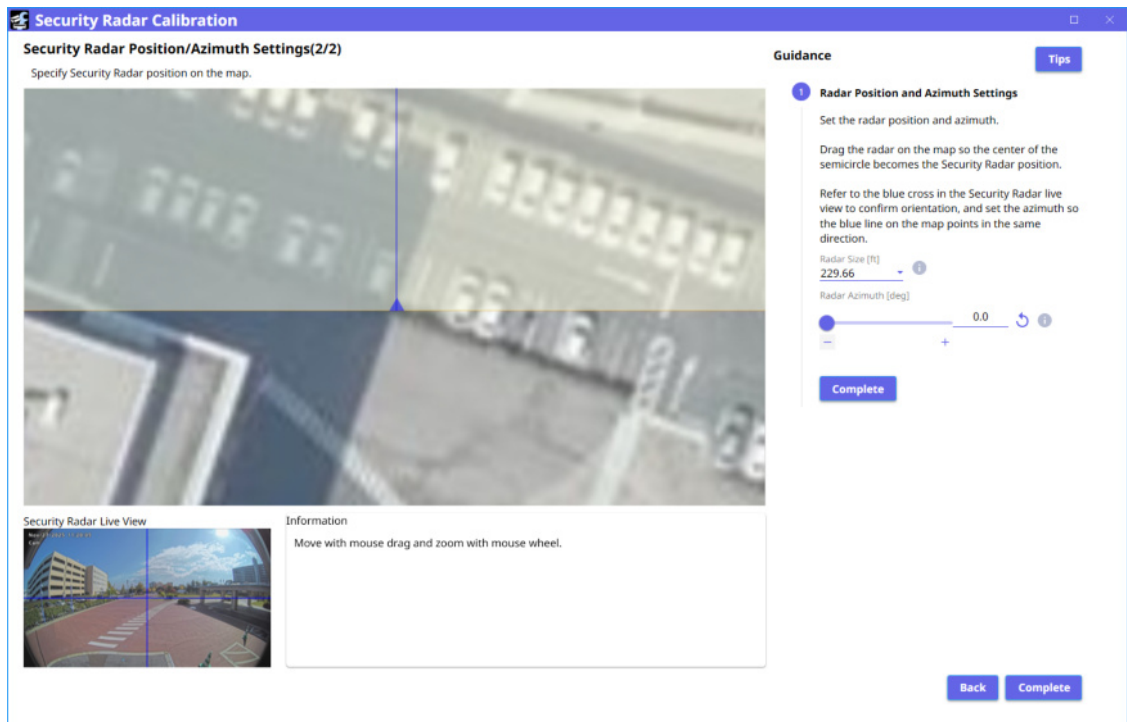

2. Adjust the azimuth of the Security Radar.

Adjust the azimuth while viewing the Security Radar live view at the bottom of the display. Rotate the radar so that the vertical line in the center of the live view of the Security Radar is the line indicating the orientation of the radar.

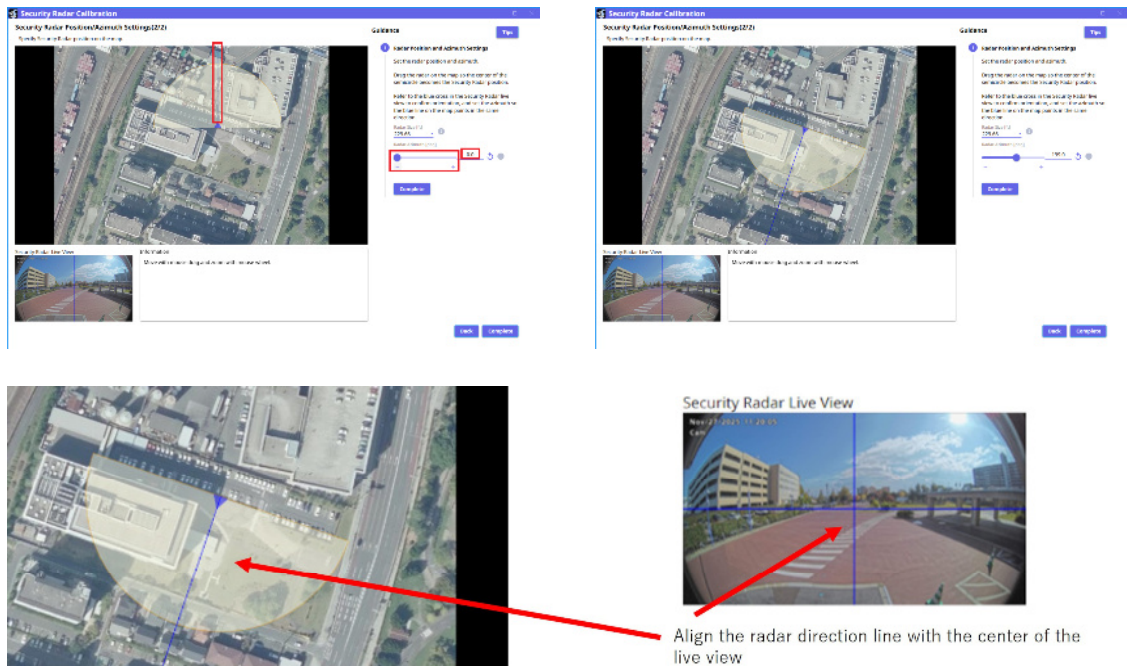

3. Select the [Complete].

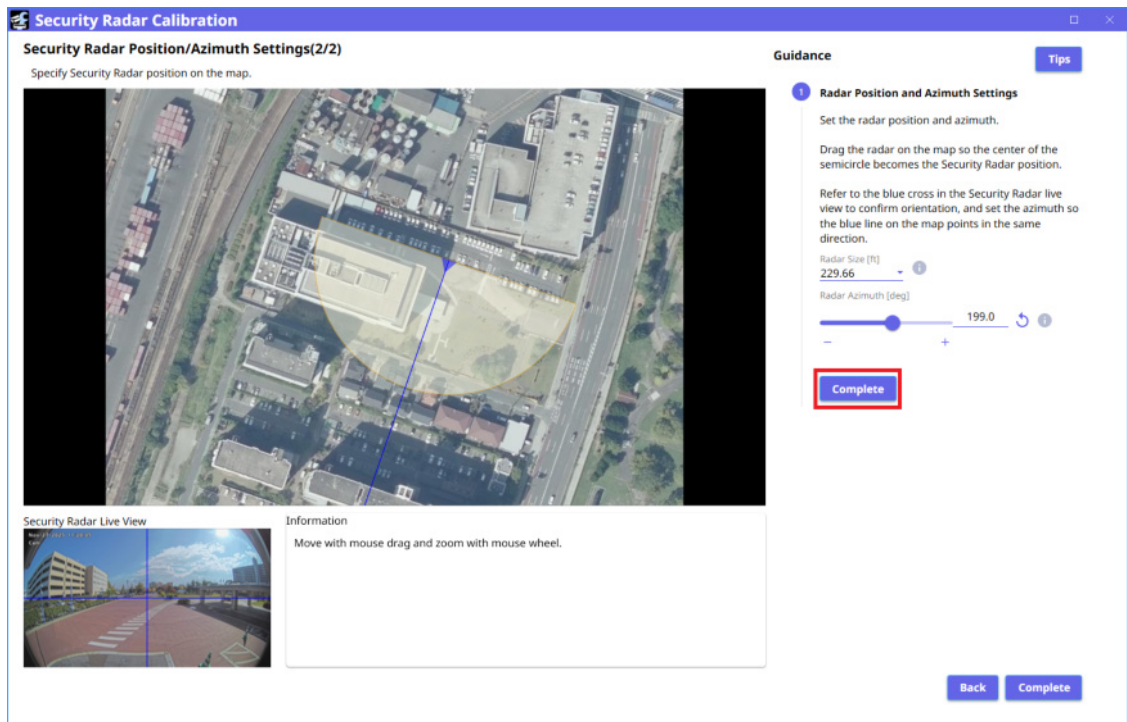

Clicking [OK] closes the Security Radar Calibration window.

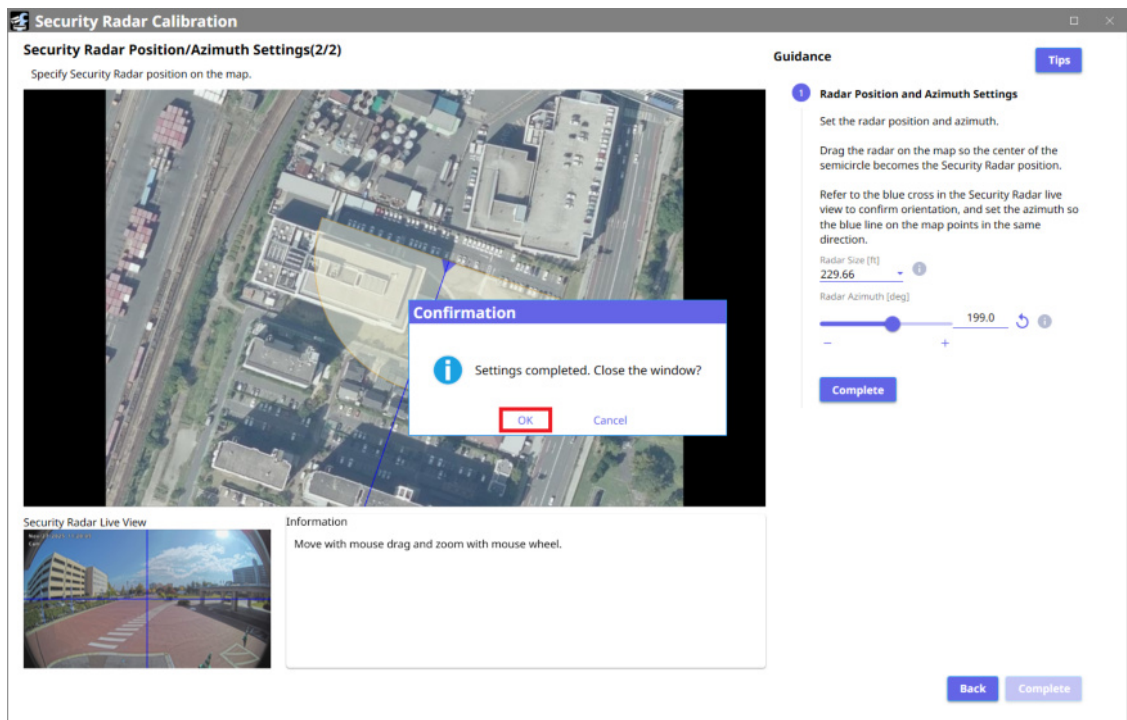

5.6.2 Detection-based Setup

Select [Detection-based Setup] and press [Execute] to open the Map Setup / Scale Calculation window.

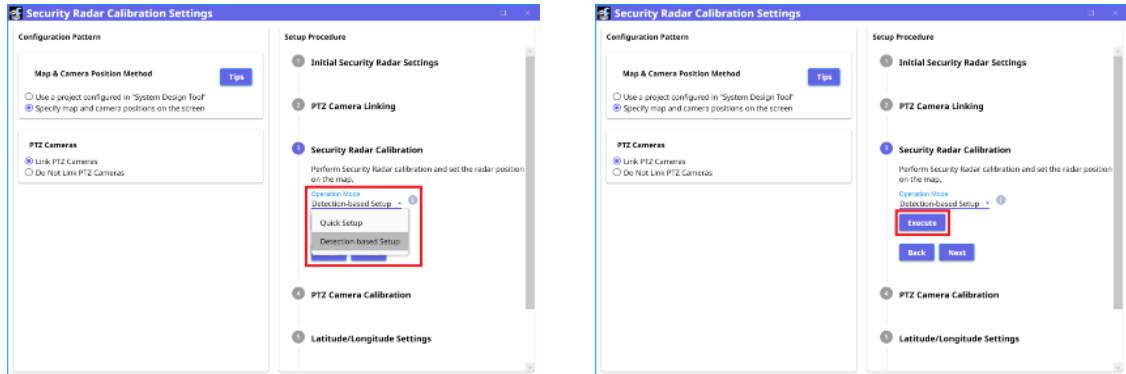

5.6.2.1 Map Registration

5.6.2.2 Map Orientation Settings

5.6.2.3 Line Settings

This is the same procedure as [5.6.1 Quick Setup](#)

5.6.2.4 Walking Test

Retrieves detection data to locate the Security Radar. Walk through the actual site and detect with Security Radar.

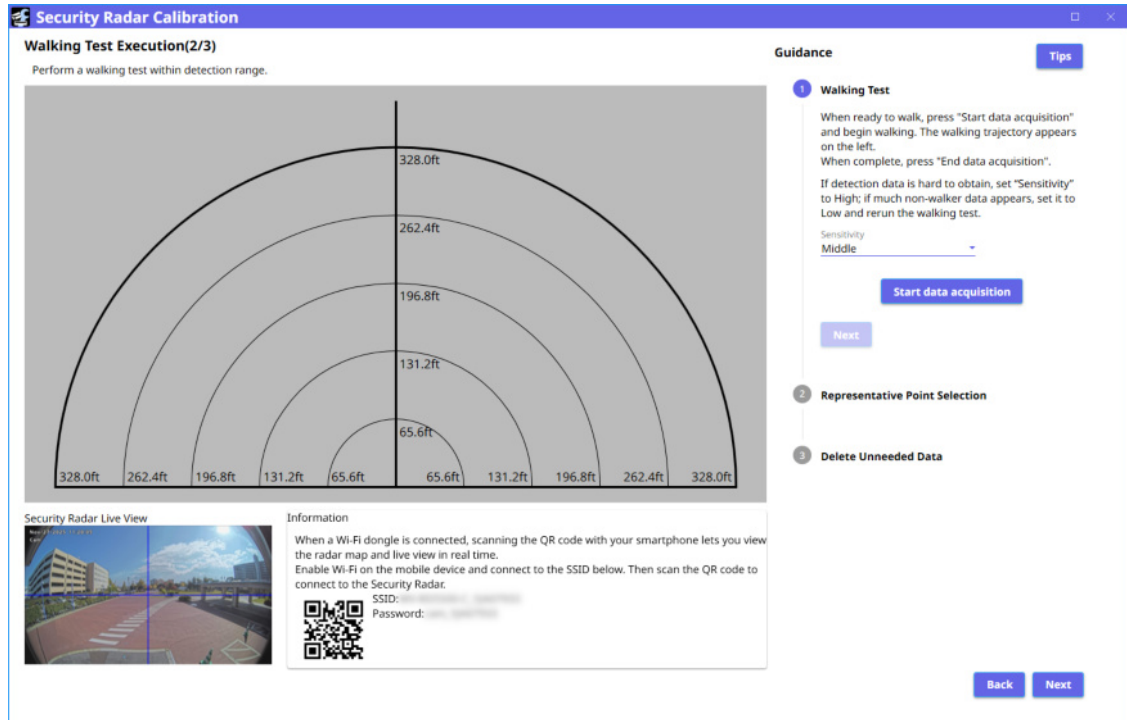

Notice

- During the walking test, select a walking area that meets the following conditions.
 - Make it a place with as clear a view as possible
 - Be as far away from the building as possible
 - There should be no persons or cars other than pedestrians
 - There should be no flags or vegetation that is shaken by large metal or wind nearby
 - No obstacle between Security Radar and pedestrian
 - If possible, walk close to the area you want to detect (recommended)
- It is desirable to change the walking route two or more times without leaving the Security Radar. Also make sure that both the vertical and horizontal directions are included toward the Security Radar. The recommended length of the walking route is 50 m to 100 m.
- If the detection data is not displayed properly while you are walking, consider reviewing the walking route in places where there are as few obstructions as possible. If it is difficult to change the route, it may be improved by switching

the detection sensitivity from Middle to High.

- If detections other than those of the pedestrian are displayed while walking, it may be improved by switching the detection sensitivity from Middle to Low.
- If you use the USB dongle, the display may not refresh in real time if it is far from the Security Radar or if there is an obstacle between it and the Security Radar.

Clicking [Start data acquisition] will show the walk detected by the Security Radar. When walk testing is complete, click [End data acquisition], and then click [Next].

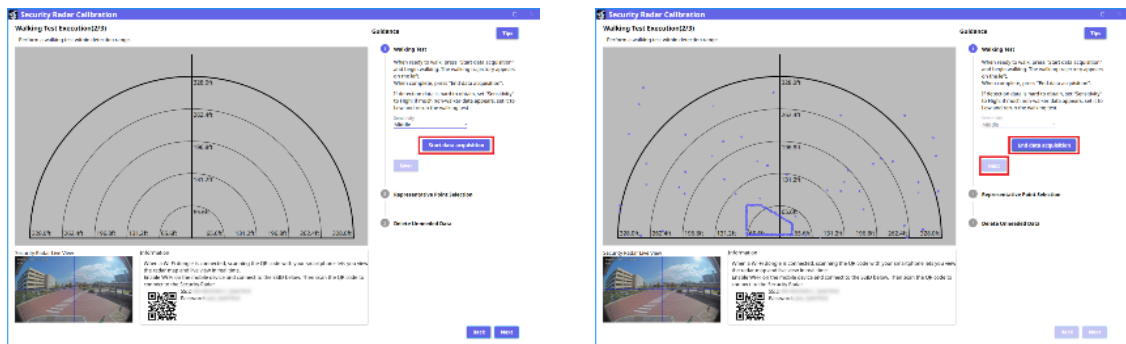

5.6.2.5 Representative Point Selection

Next, specify a representative point from the detection data. When the detection data is clicked, it is displayed as a red circle, and that point becomes a representative point. Select a representative point from the acquired discovery data. Then, select [Next].

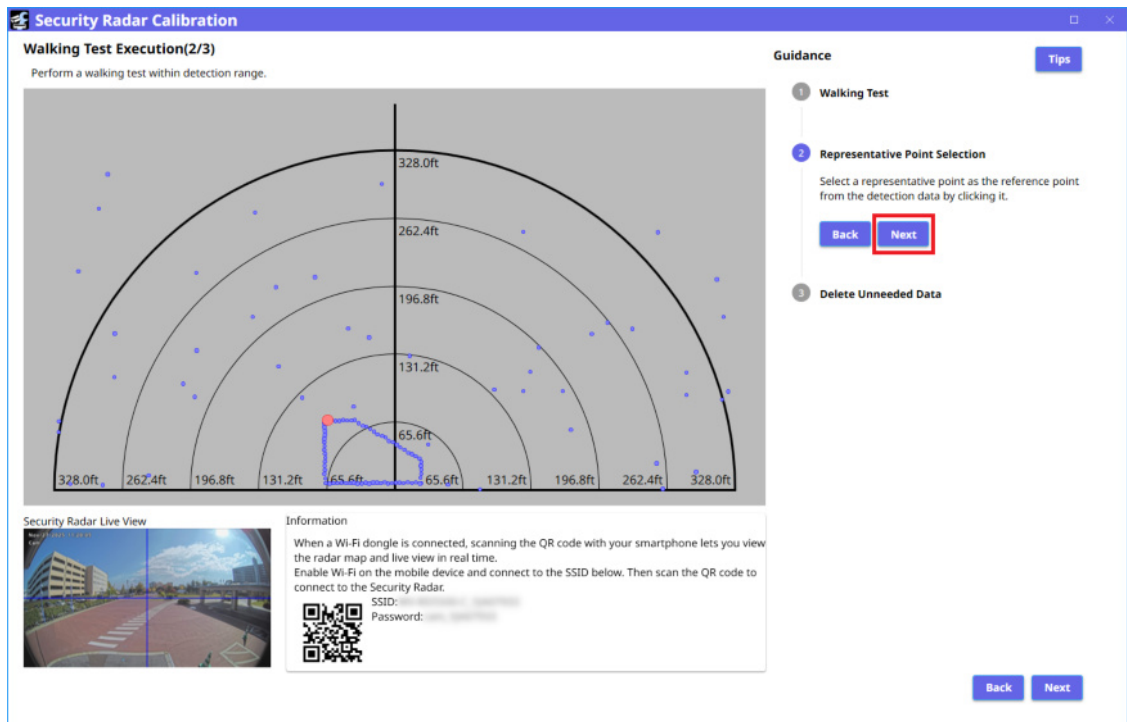

The representative point is not a problem anywhere, but please specify a position that is as easy as possible to understand (e.g. around the yellow circle in the figure).

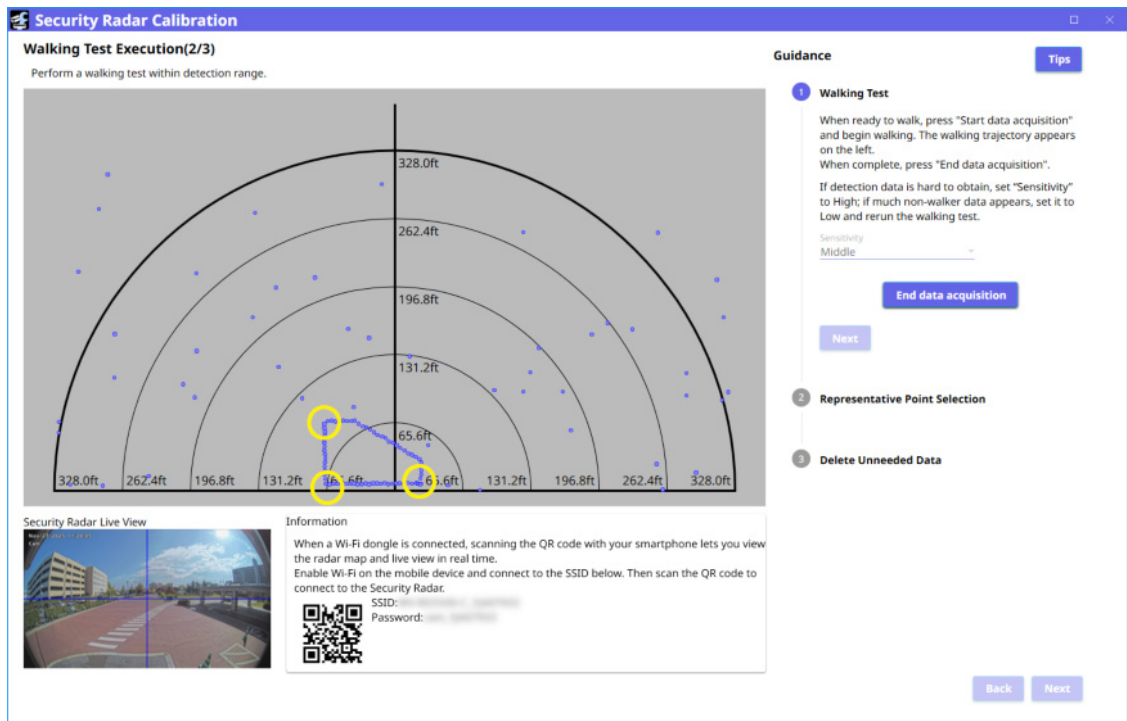

5.6.2.6 Delete Unneeded Data

Delete points detected on the screen that are determined to be non-pedestrian detection data.

When the detection data to be deleted is specified by left-clicking, the color of the detection data changes to blue → gray. You can delete unwanted detection data by clicking [Delete detection data]. Repeat this operation to delete all unnecessary data. When you are finished, select [Complete] or [Next].

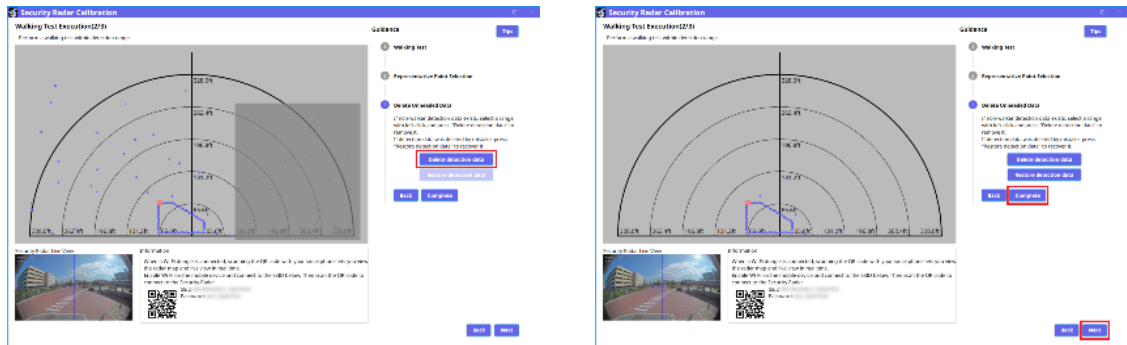

Notice

If there is a lot of detection data other than pedestrians, the the last judgment may be ❌, so please delete it as much as possible.

5.6.2.7 Walking Area Drawing

The position and azimuth of the Security Radar are calculated based on the walking test.

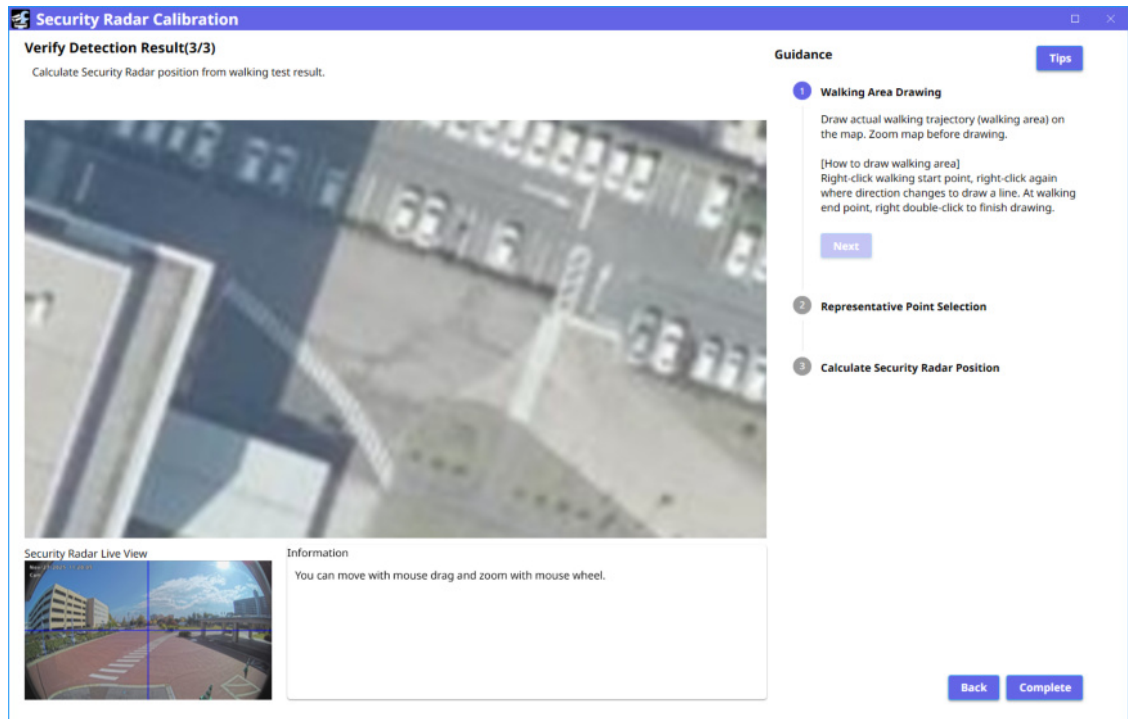

Draw the walked route on the map. Right-click at the point where you started the walk test on the map, and right-click again at the point where you changed the direction of the walk and draw a straight line between them. Double-click right-click at the end of the walk test to complete the drawing. When you have finished drawing, press [Next]. In the walking area, use the mouse wheel to expand the map as much as possible and draw accurately.

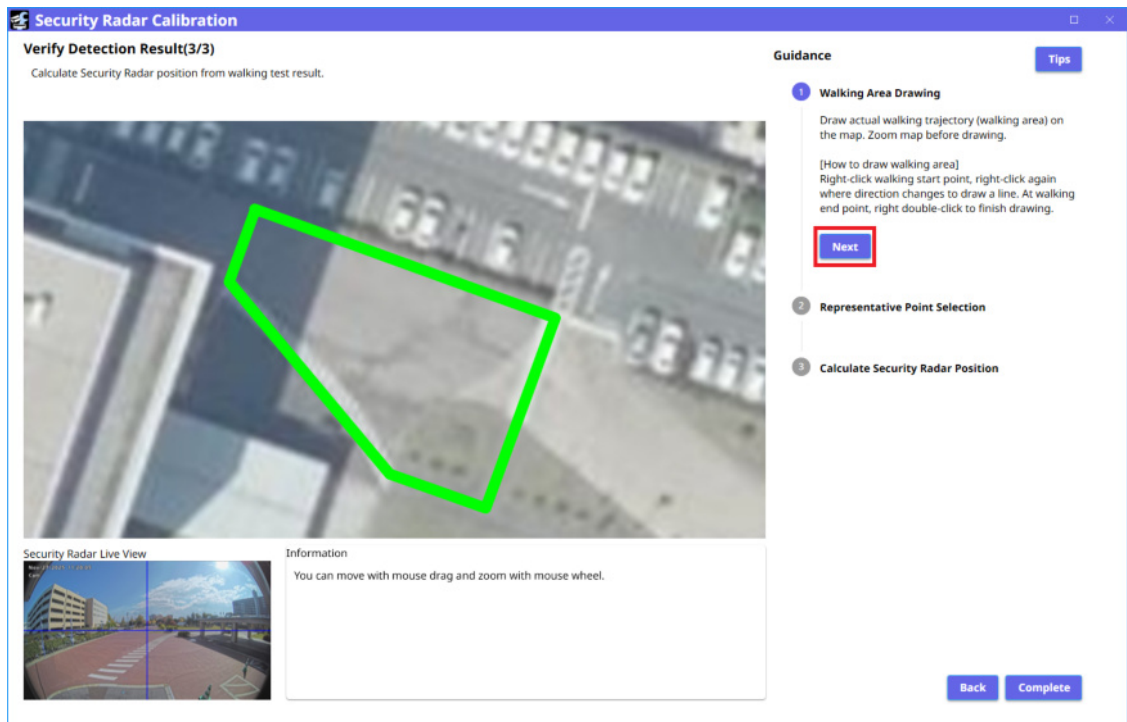

✔: Case where the image is correctly rendered

✘: Cases that cannot be drawn correctly (Left: Not enlarged / Right: The actual walking route and area are out of alignment)

*The red dotted line indicates the actual walking route.

5.6.2.8 Representative Point Selection

After drawing the walking area, move the pin icon to the position of the representative point that was set during the walking test. After completing, press [Next].

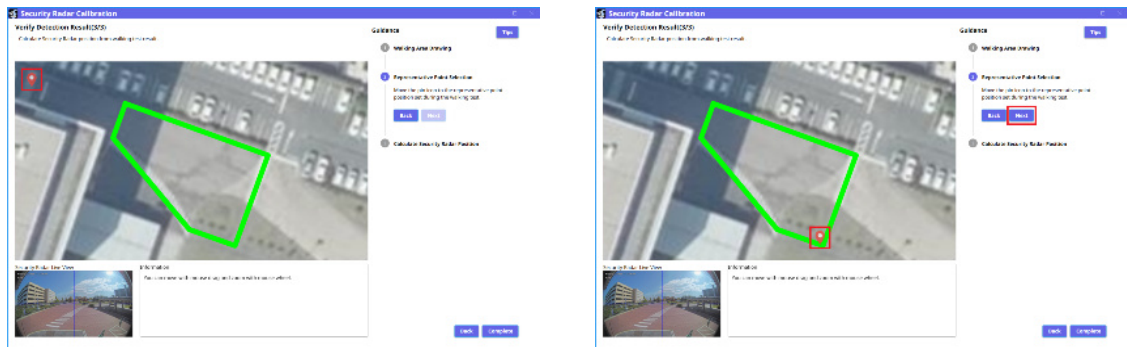

5.6.2.9 Calculate Security Radar Position

When [Calculate Security Radar Position] is clicked, the Security Radar position is calculated based on the Security Radar detection data and the walking area.

In the judgment result if the position is calculated normally  is displayed. After calculating, press [Complete].

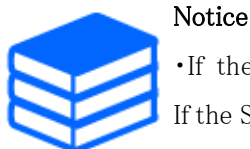
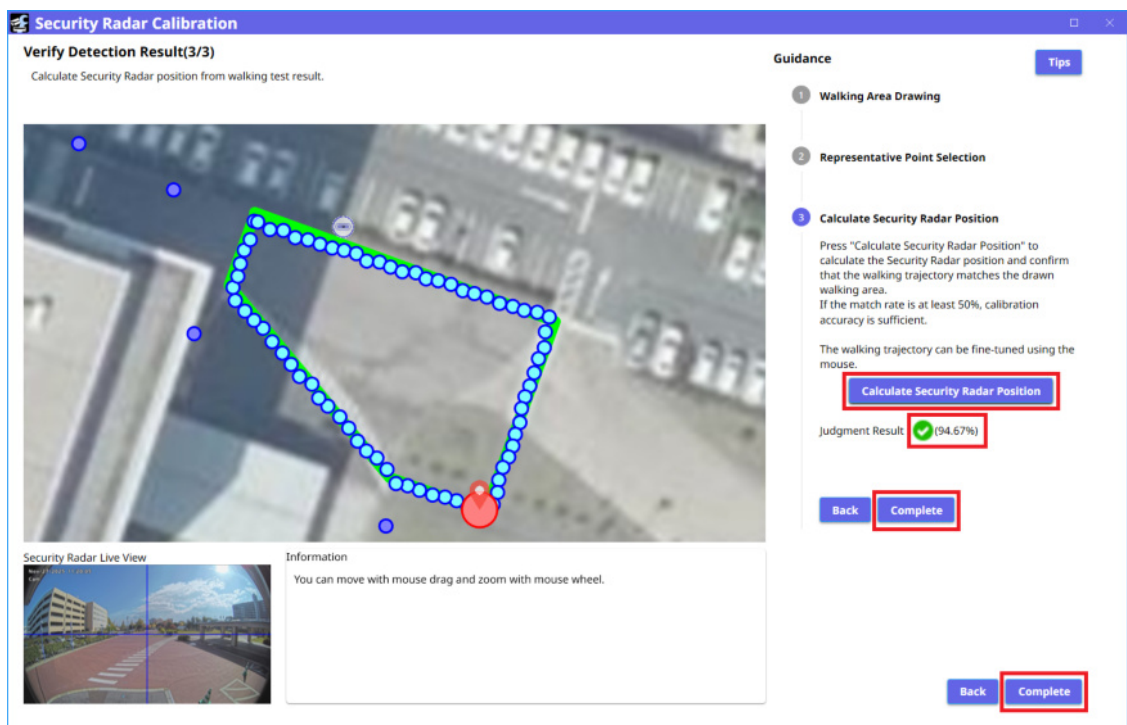

Notice

- If the Security Radar position is not calculated correctly
- If the Security Radar position is incorrect even though the judgment is normal, check that the position of the representative point is correct. If the problem persists, start acquiring walking data again.

If a problem occurs for any reason, an error similar to the following is displayed. Take the

appropriate action as described in the manual.

Judgment Result ❌

Error: Match Rate(49.33%)

Return to "Walking Test Execution" screen, delete non-walker detection data and retry. If still not improved, recheck possible causes below:

- Incorrect walking area position
- Incorrect representative point position
- Incorrect map scale information

Judgment Result ❌

Error: Calibration Failed

Recheck possible causes below:

- Using map without radar position
- Incorrect walking area position
- Incorrect representative point position
- Incorrect map scale information

Clicking [OK] closes the Security Radar Calibration window.

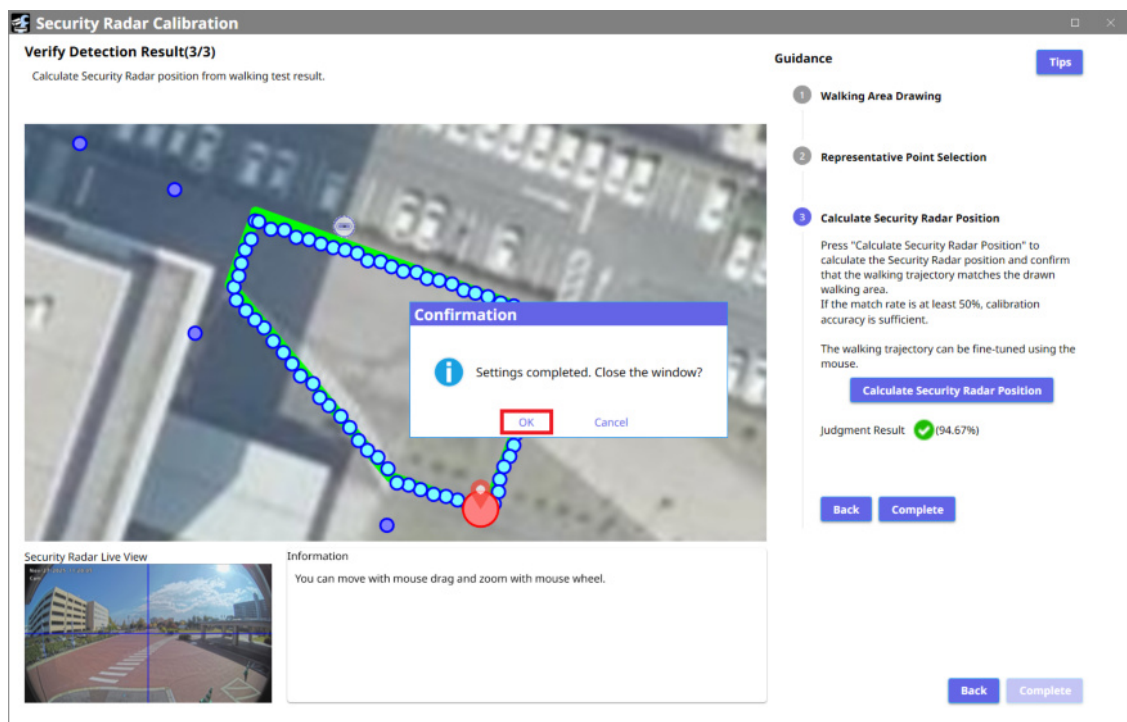

5.7 PTZ Camera Calibration

Clicking [Execute] displays the PTZ Camera Calibration window.

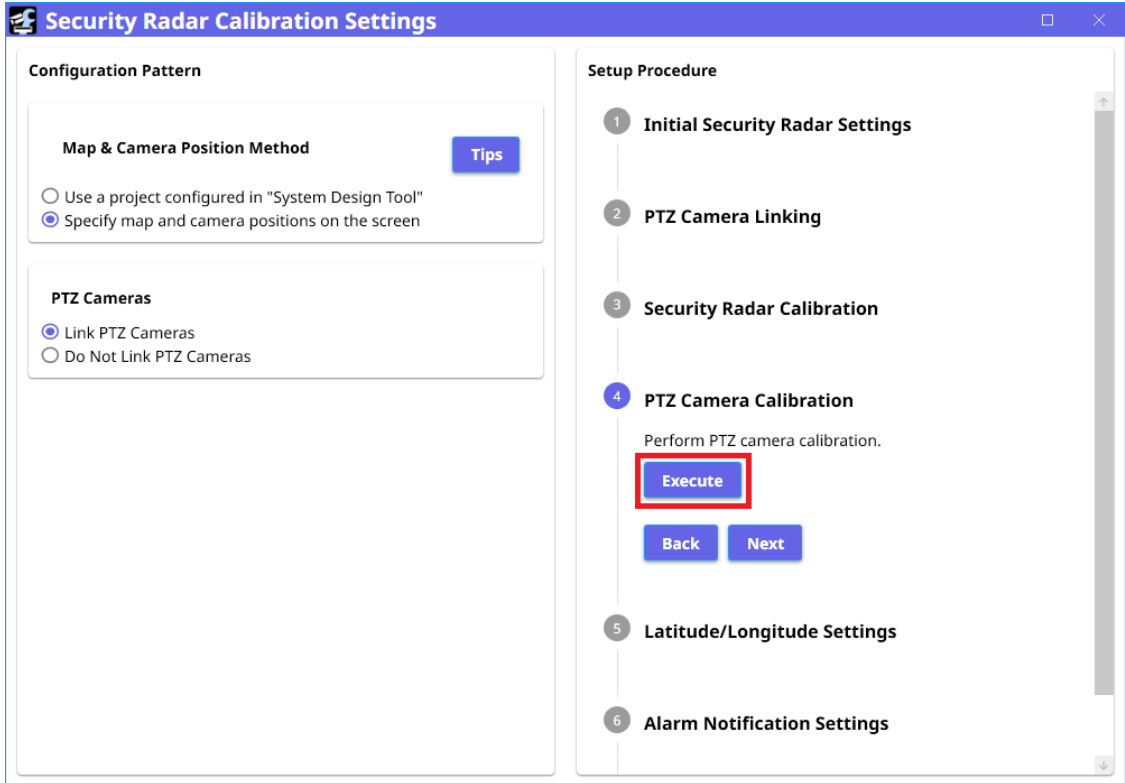

The information of the camera for which linkage has been set is displayed. Clicking [Calibration] in each camera information displays the calibration window of the target PTZ camera.

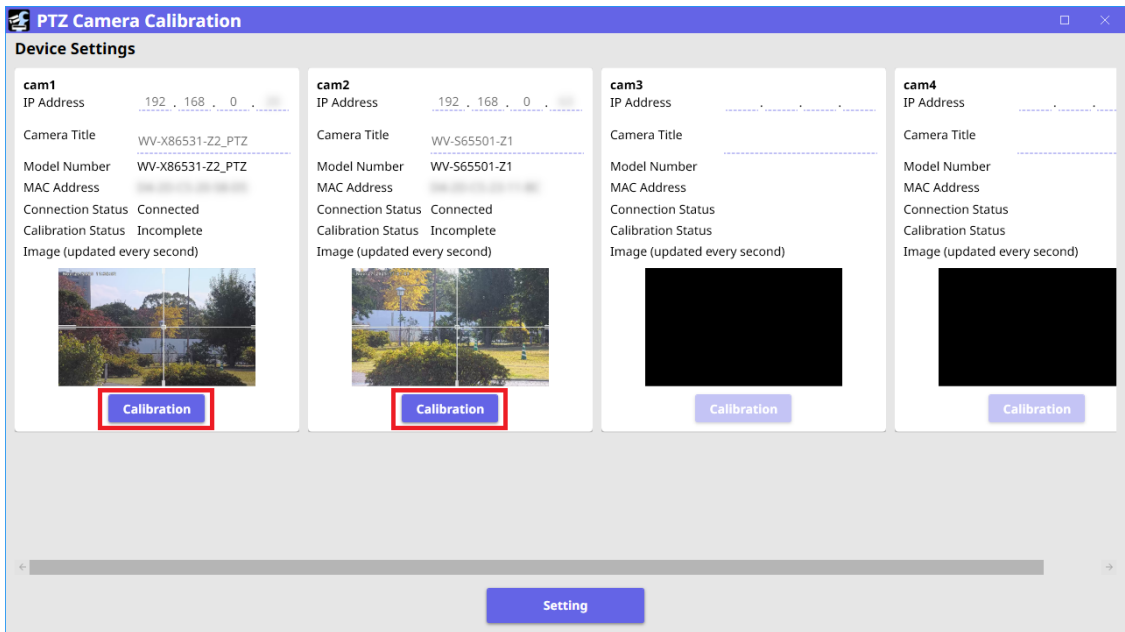

PTZ Camera Calibration

PTZ Camera Position Adjustment

Set the PTZ camera position and the calibration reference point.

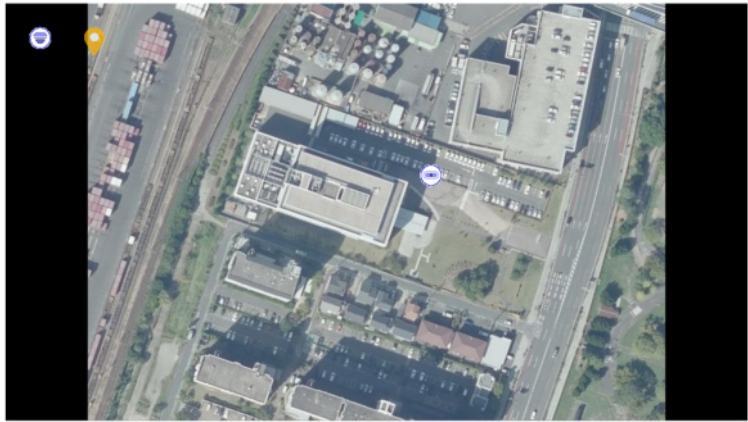

Security Radar Live View



Information

Move with mouse drag and zoom with mouse wheel.

Guidance

1 PTZ Camera and Calibration Reference Position Settings

Move the camera icon to the PTZ camera position and the pin icon to the calibration reference point on the map. PTZ cameras not in calibration are shown in gray.

Position the calibration reference point where the PTZ camera can see the ground and preferably at least 10 m away from the PTZ camera.

Next

2 PTZ Camera Viewing Angle Adjustment

Complete

5.7.1 PTZ Camera and Calibration Reference Position Settings

Move the camera icon to the location on the map where the PTZ camera is located.

Next, move the pin position to the calibration reference point. Move the camera in an enlarged state as much as possible.

PTZ cameras that have already been set are grayed out. When you have finished making settings, press [Next].



Notice

The calibration reference point is the position to be projected to adjust the PTZ camera. You can set it anywhere if all of the following conditions are met.

- Reflecting the ground of the calibration reference point from the PTZ camera
- The distance from the PTZ camera-to-calibration reference point is at least 10m
- The location must be within the scope of the map

5.7.2 PTZ Camera Viewing Angle Adjustment

Adjust the angle of view so that the ground at the calibration reference point is in the center of the PTZ shooting window. Clicking on a live view moves the center of the screen to the click position. Increase the zoom factor to ensure high-precision adjustment. If necessary, use the pan and tilt operations to make adjustments.

When you have finished making settings, press [Complete].

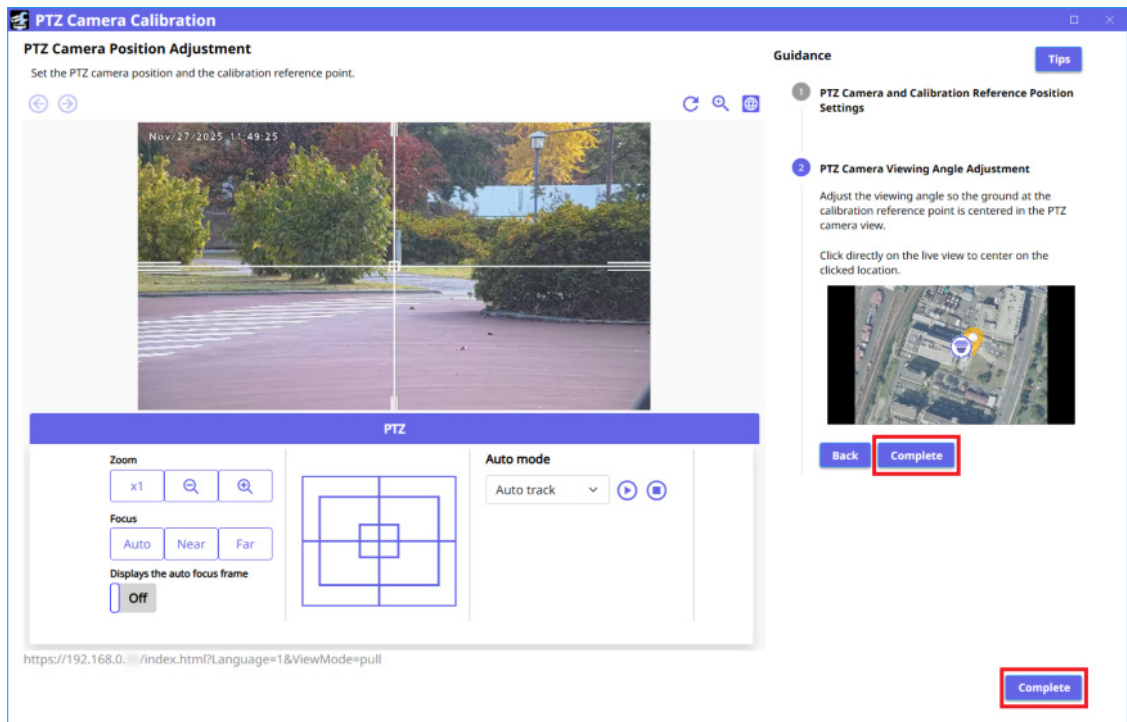

Notice

When the following items are enabled, the angle of view may move after adjustment. Therefore, it is recommended to disable it in advance.

- Auto track
- Auto pan
- Preset sequence
- Home position
- Position refresh
- Self return

etc.

Clicking the [Complete] button displays a message. Click [OK].

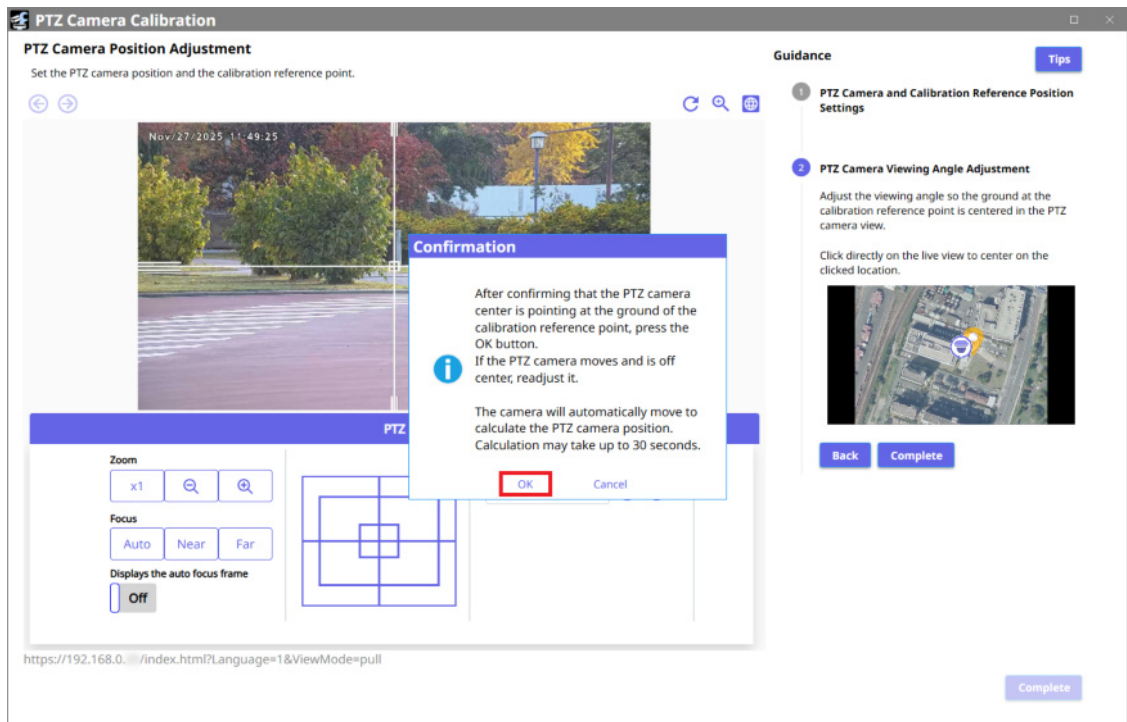

When the setting is completed successfully, a message will be displayed on the screen. Click [OK].

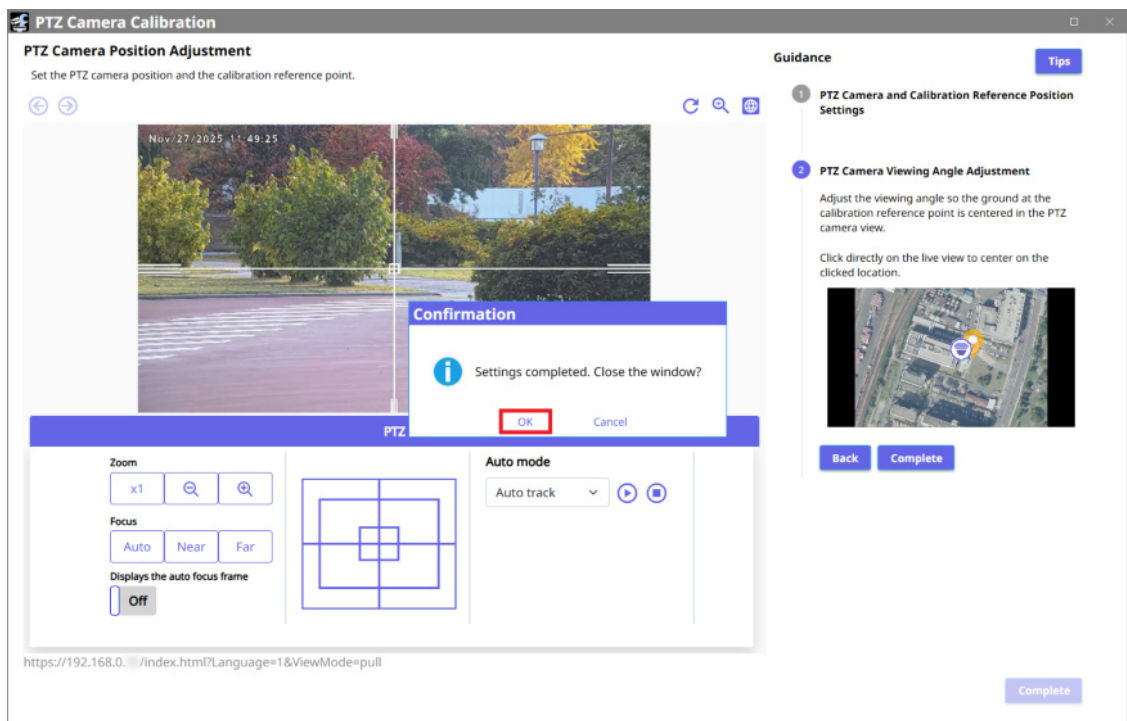

The "Calibration Status" item for Camera 1 changes to "Complete" and the calibration of Camera 1 ends. Calibrate Camera 2 in the same way.

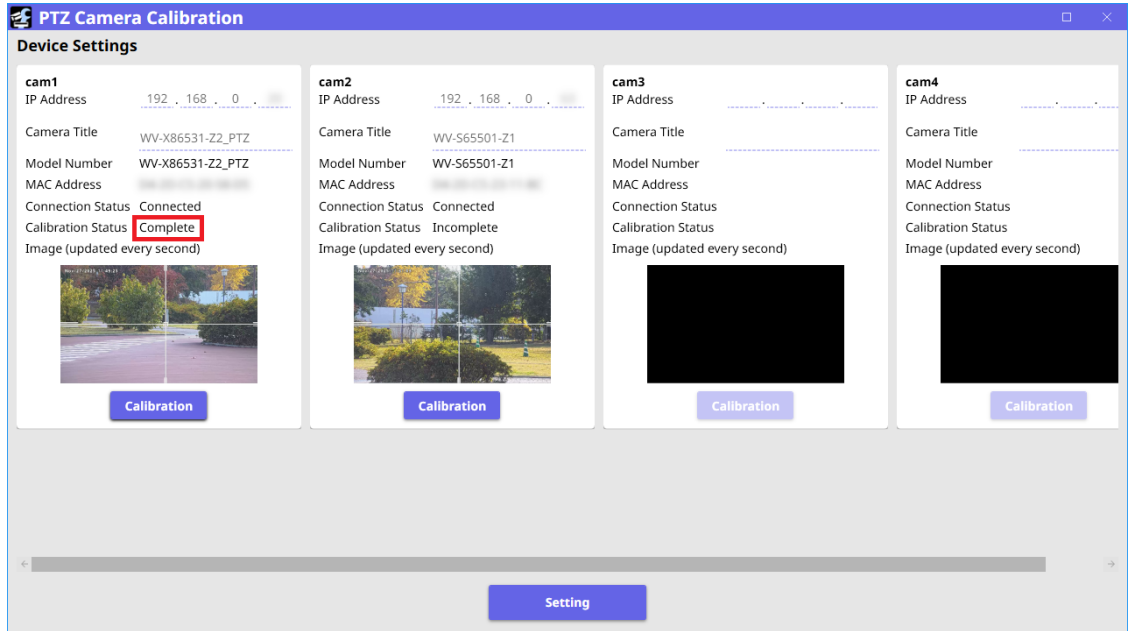

Finally, click [Setting] and when the message "Completed." appears, click [OK] to exit.

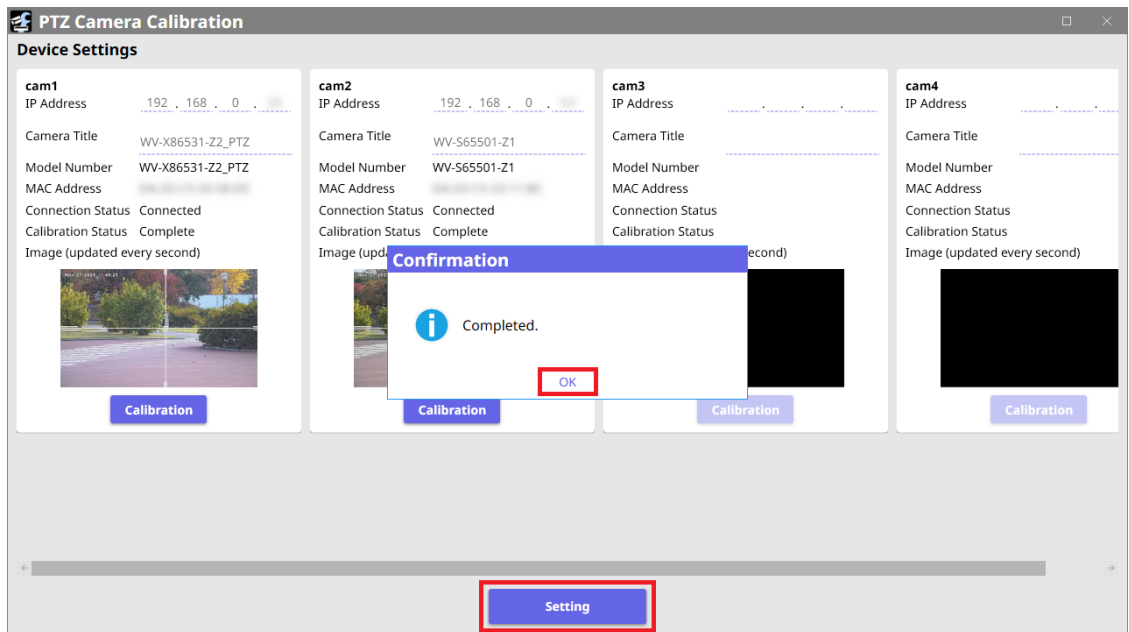

5.8 Setting latitude and longitude information

Sets the Security Radar longitude and latitude. By setting latitude and longitude information, location information can be added to the ONVIF stream and linked by an external system. Select [Disable] if you do not want to use location information on the external system. Then, select [Next].

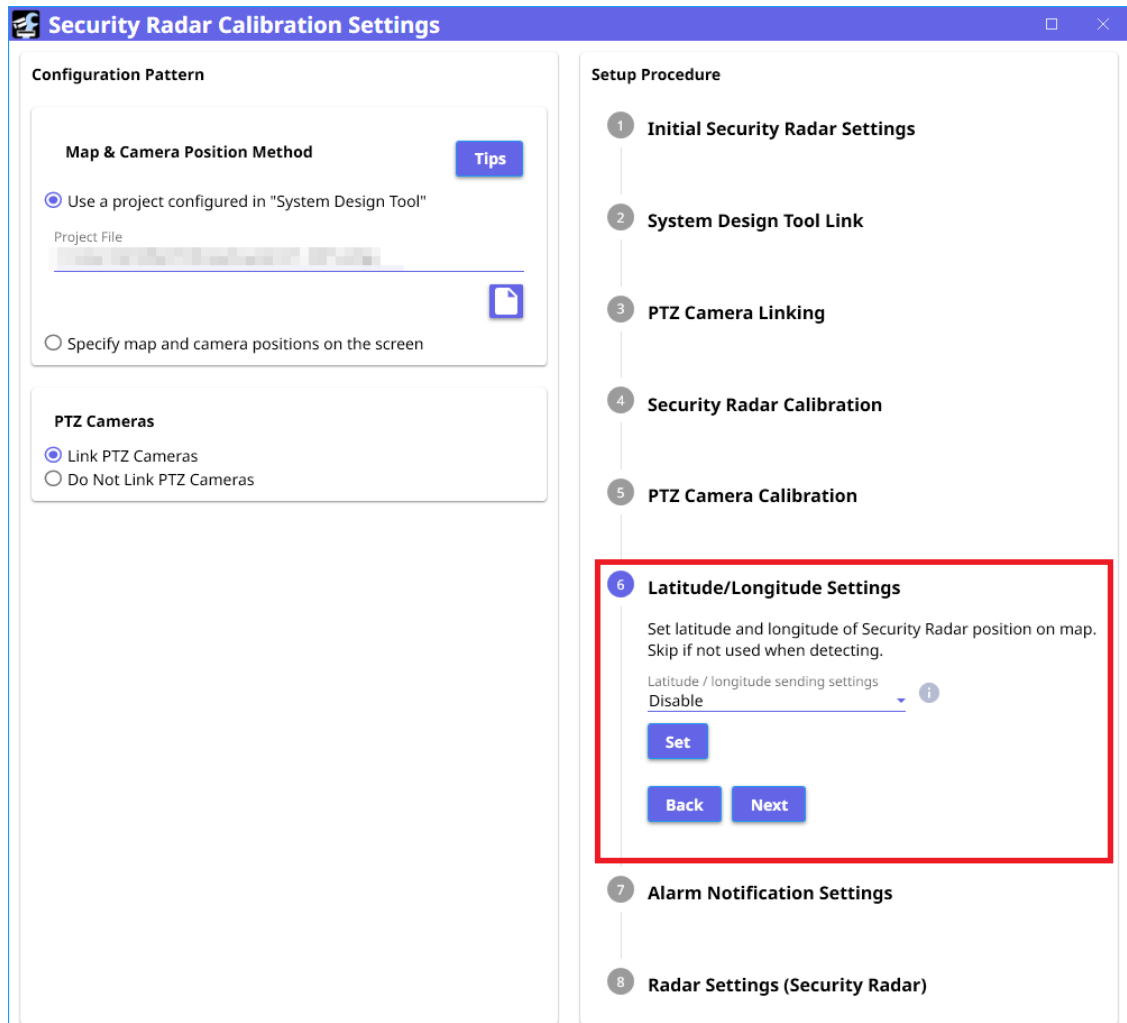

If enabled, switch the [Latitude / longitude sending settings] to [Enable], enter the [Latitude] and [Longitude] for the Security Radar, and press [Set]. After completing the settings, press [Next].

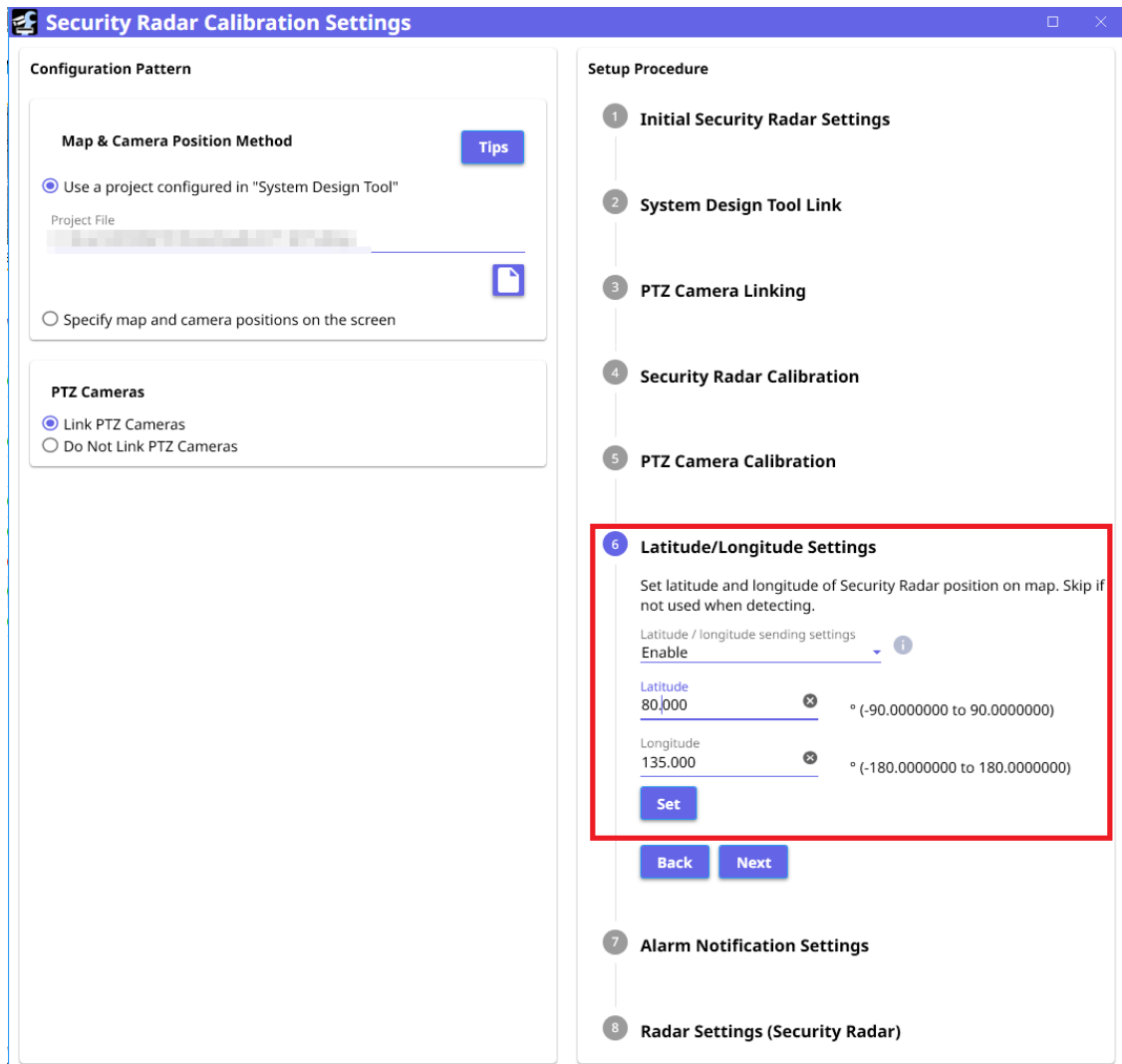

5.9 Alarm notification setting

You can set all the alarm notification settings to Security Radar and PTZ to notify the external systems.

If notification to the external system is not required, the setting is not required. Select [Disabled] and select [Next].

1. Select the [Set] checkbox and enter the IP address of the external device. "Example: 192.168.0.112"
 2. Clicking the [Set] button displays the dialog box for setting the connected device.
 3. When the setting is completed, the message [Completed] is displayed. Click [OK].
- After setting the alarm notification for the required device, select [Next].

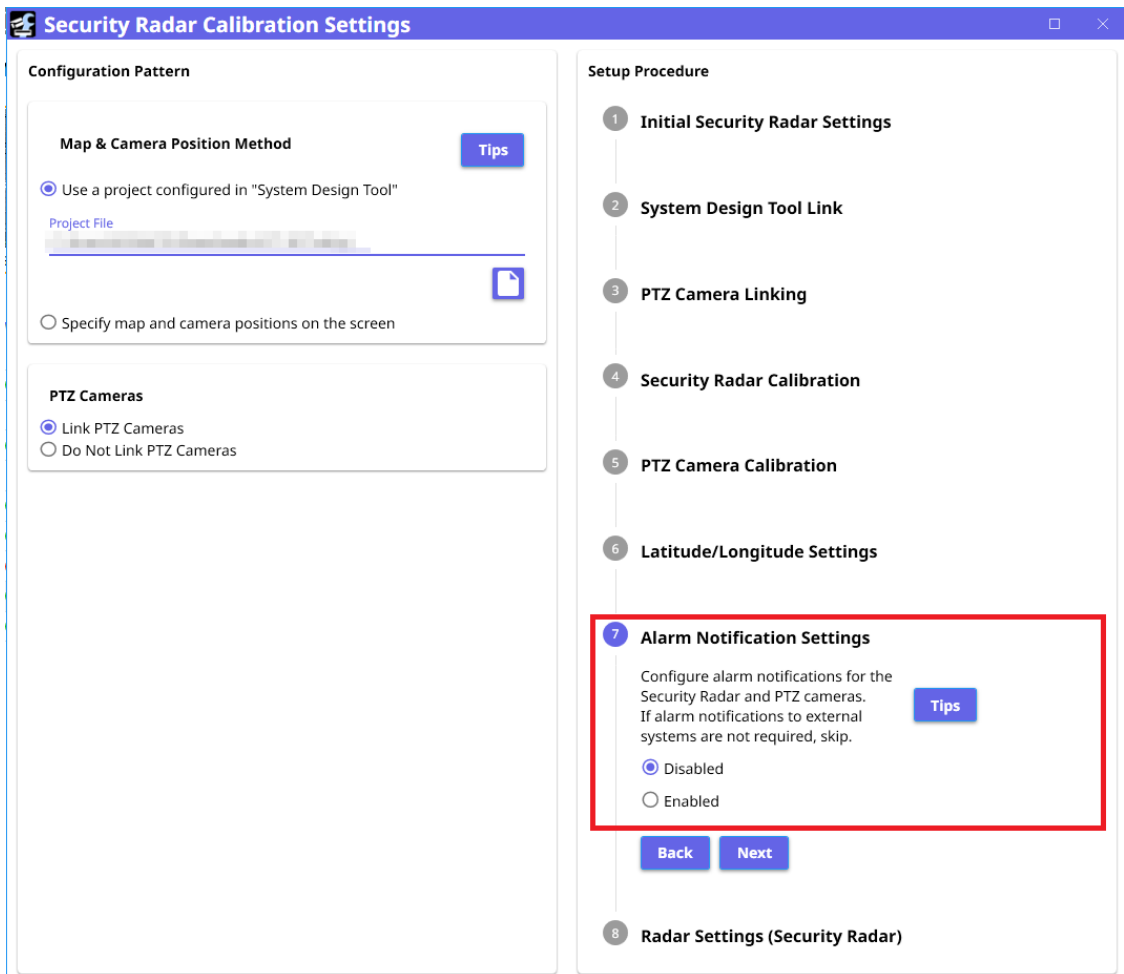

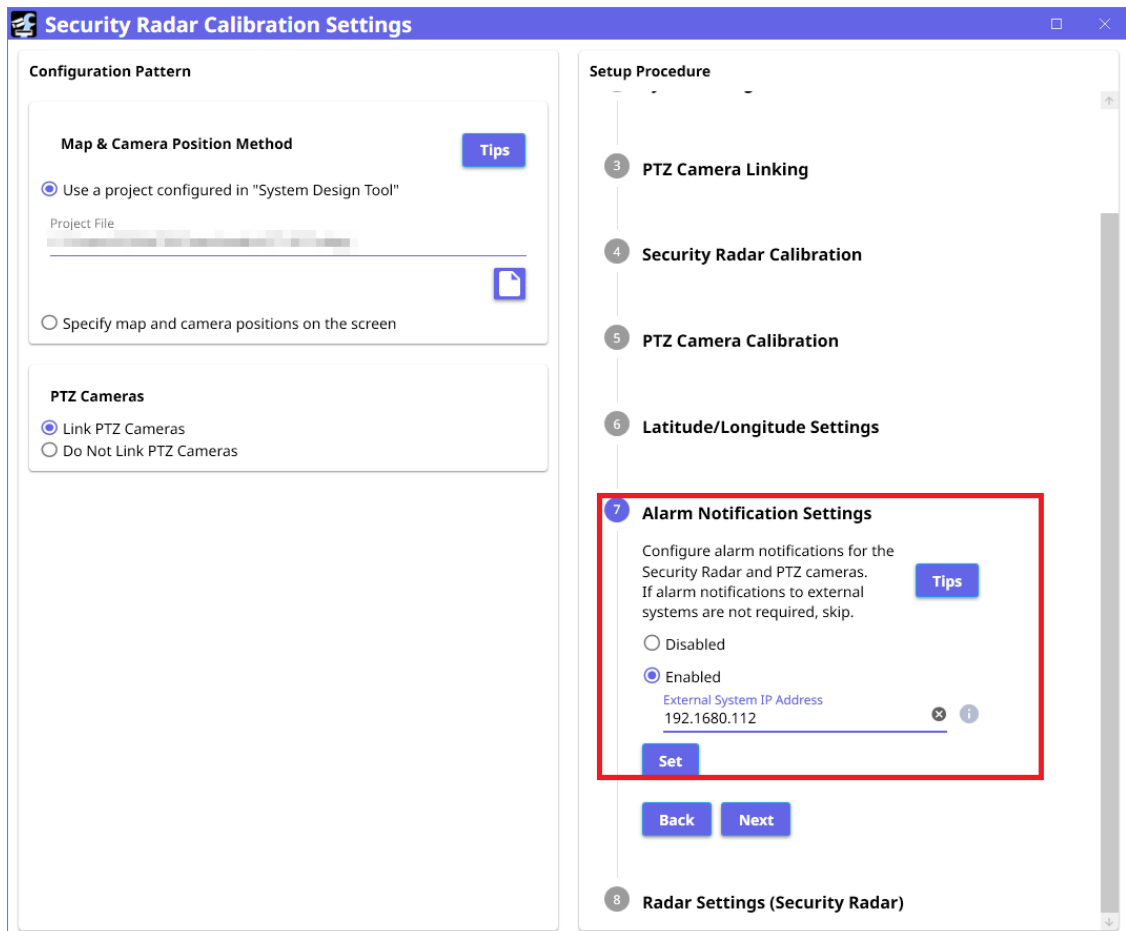

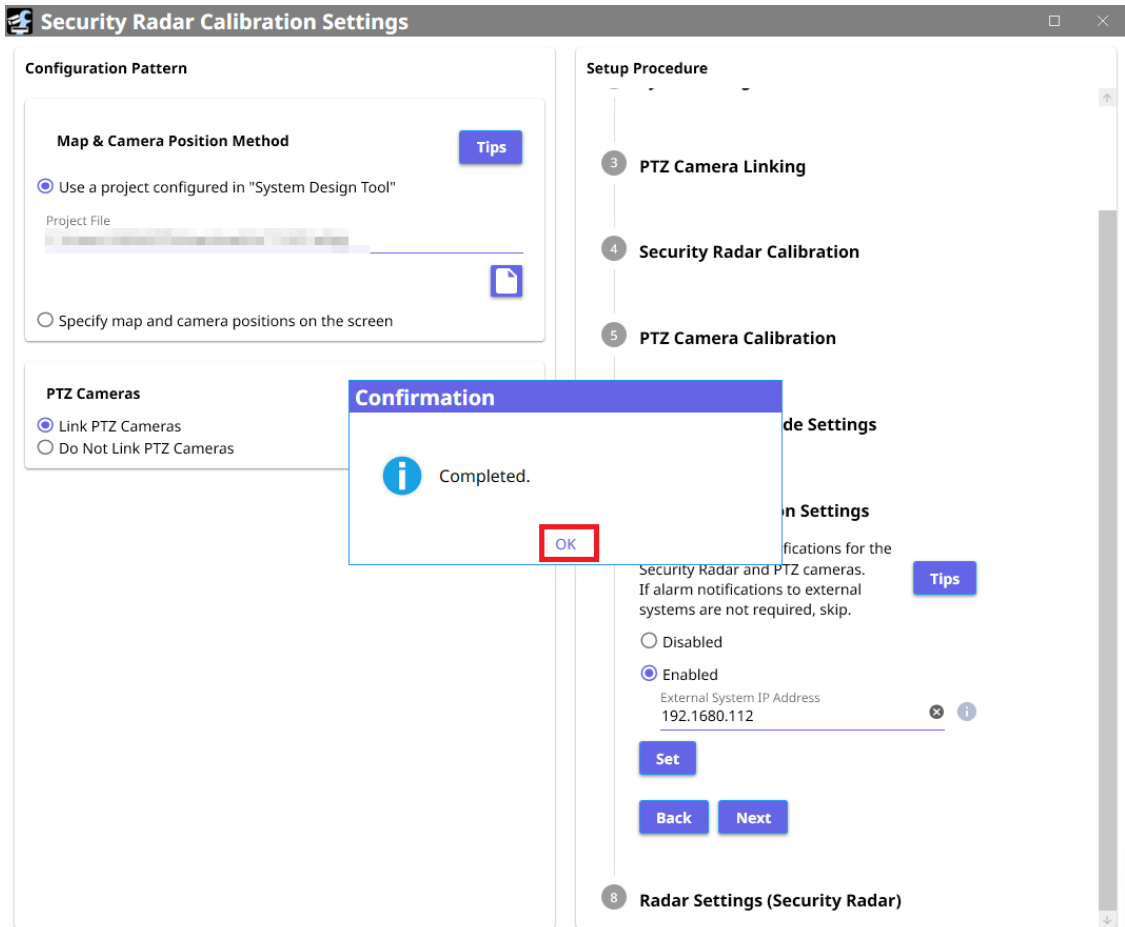

When four PTZ cameras are linked from Security Radar and notified to an external systems, notification is performed as follows. Specific IP addressing is provided as an example.

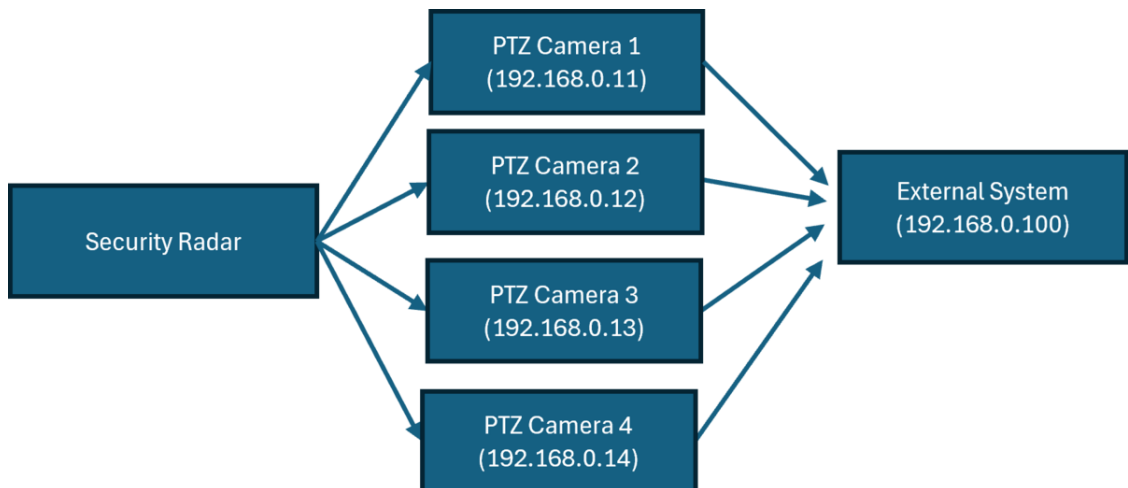

The following alarm settings are set by configuring the settings.

Security Radar

Alarm VMD area SCD area Audio detection Impact detection **Notification**

TCP alarm notification | **HTTP alarm notification**

TCP alarm notification On Off

Additional alarm data On Off

Destination port 1818 (1-65535)

Retry times 2

Destination of notification	Alarm	Diag.	Destination server address
Address 1	<input checked="" type="checkbox"/>	<input type="checkbox"/>	192.168.0.11 Delete
Notification per Camera	<input type="radio"/> On	<input checked="" type="radio"/> Off	
Notification per Radar detection/VMD area	<input type="radio"/> On	<input checked="" type="radio"/> Off	Alarm area No. <input type="text"/>
Address 2	<input checked="" type="checkbox"/>	<input type="checkbox"/>	192.168.0.12 Delete
Notification per Camera	<input type="radio"/> On	<input checked="" type="radio"/> Off	
Notification per Radar detection/VMD area	<input type="radio"/> On	<input checked="" type="radio"/> Off	Alarm area No. <input type="text"/>
Address 3	<input checked="" type="checkbox"/>	<input type="checkbox"/>	192.168.0.13 Delete
Notification per Camera	<input type="radio"/> On	<input checked="" type="radio"/> Off	
Notification per Radar detection/VMD area	<input type="radio"/> On	<input checked="" type="radio"/> Off	Alarm area No. <input type="text"/>
Address 4	<input checked="" type="checkbox"/>	<input type="checkbox"/>	192.168.0.14 Delete
Notification per Camera	<input type="radio"/> On	<input checked="" type="radio"/> Off	
Notification per Radar detection/VMD area	<input type="radio"/> On	<input checked="" type="radio"/> Off	Alarm area No. <input type="text"/>

PTZ Camera 1-4

Alarm VMD area SCD area Audio detection **Notification**

TCP alarm notification | **HTTP alarm notification**

TCP alarm notification On Off

Additional alarm data On Off

Destination port 1818 (1-65535)

Retry times 2

Destination of notification	Alarm	Diag.	Destination server address
Address 1	<input checked="" type="checkbox"/>	<input type="checkbox"/>	192.168.0.100 Delete
Auto track cooperation	<input type="radio"/> On	<input checked="" type="radio"/> Off	Alarm area No. <input type="text"/>

Alarm VMD area SCD area Audio detection **Notification**

Alarm

Terminal 1

Terminal 2

Terminal 3

VMD alarm VMD >>

SCD alarm SCD >>

Auto track alarm Auto track setting >>

Audio detection alarm Audio detection >>

Command alarm On Off

Reception port 1818 (1-65535)

Alarm deactivation time 5 s (0.5s-1-600s)

Alarm test **Execute**

5.10 Radar Settings (Security Radar)

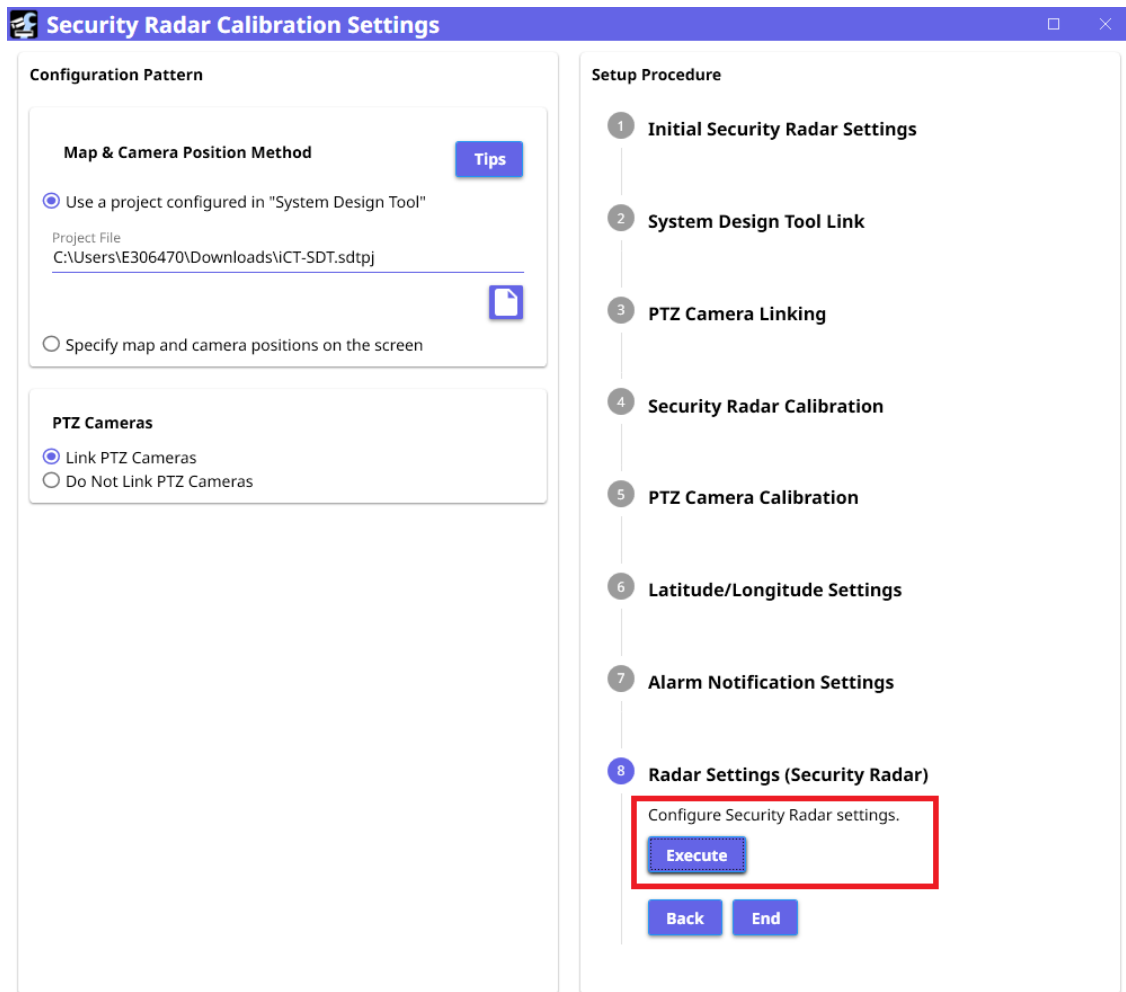

Clicking [Execute] displays the following window.

(Radar settings can also be changed by accessing the Security Radar directly using browsers.)

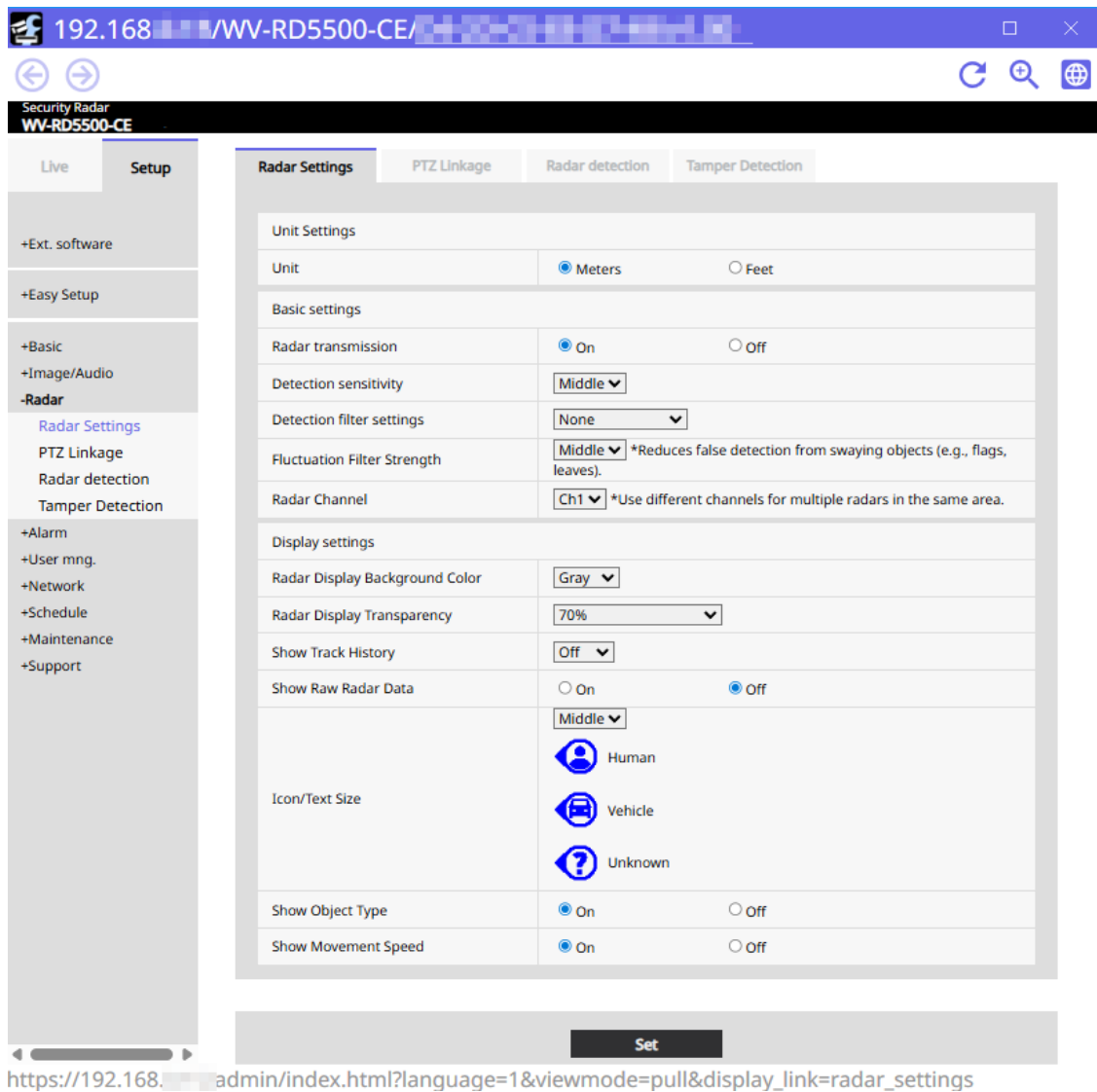

5.10.1 Radar Settings

5.10.1.1 Unit Settings

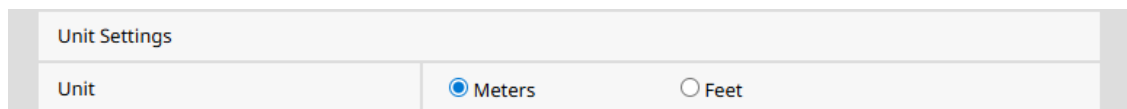

Set the unit of the distance value to be entered.

[Setting Value] Meters/Feet

[Default] Meters

5.10.1.2 Basic Settings

Basic settings	
① Radar transmission	<input checked="" type="radio"/> On <input type="radio"/> Off
② Detection sensitivity	Middle ▾
③ Detection filter settings	None ▾
④ Fluctuation Filter Strength	Middle ▾ *Reduces false detection from swaying objects (e.g., flags, leaves).
⑤ Radar Channel	Ch1 ▾ *Use different channels for multiple radars in the same area.

① Radar transmission

Controls the radar transmission.

[Setting Value] On: Radar transmission/Off: Radar transmission is not performed.

[Default] On

② Detection sensitivity

Set the radar detection sensitivity. If you want to reduce false positives, select Low and if it is difficult to detect the object, select High and check again.

[Setting Value] Low: Sensitive Low/Middle: Sensitive Medium/High: Sensitive High

[Default] Middle

③ Detection filter settings

Specify the target for priority detection. Depending on the specified filter, the upper and lower limits of the speed range and size range change.

[Setting Value] None/Priortize People/Priortize Vehicle

[Default] None

④ Fluctuation Filter Strength

Sets the degree to which objects such as flags and branches of trees that are shaky are removed to prevent false positives.

[Setting Value] Off: No removal/Low: Lower degree of removal/Middle: Moderate degree of removal/High: High degree of removal

[Default] Middle



⑤ Rader Channel

In order to avoid interfering with each other when several Security Radar are used, the channels can be set.

[Setting Value] Ch1/Ch2/Ch3/Ch4/Ch5/Ch6

[Default] Ch1

5.10.1.3 Display Settings

Display settings	
① Radar Display Background Color	Gray ▾
② Radar Display Transparency	70% ▾
③ Show Track History	Off ▾
④ Show Raw Radar Data	<input type="radio"/> On <input checked="" type="radio"/> Off
⑤ Icon/Text Size	Middle ▾  Human  Vehicle  Unknown
⑥ Show Object Type	<input checked="" type="radio"/> On <input type="radio"/> Off
⑦ Show Movement Speed	<input checked="" type="radio"/> On <input type="radio"/> Off

①Radar Display Background Color

[Setting Value] Gray/White

[Default] Gray

②Radar Display Transparency

[Setting Value] Off (no transparency)/30%/40%/50%/60%/70%/80%/90%

[Default] 70%

③Show Track History

Track history refers to tracks that remain when the target of radar detection moves.

In this setting, the display time of this track history is set.

[Setting Value] Off: Trajectory is not displayed.

3s/5s/10s/20s/30s/1min/2min/1h/24h: Trajectory is displayed during the specified period.

[Default] Off: Trajectory is not displayed.

④Show Raw Radar Data

Raw radar data refers to raw data before radar detection. Includes noise such as leaf sway.

[Setting Value] On: Display raw radar data/Off: Do not display raw radar data

[Default] Off: Do not display raw radar data

⑤Icon/Text Size

[Setting Value] Small: 16 pixels/Middle: 32 pixels/Large: 48 pixels

[Default] Middle: 32 pixels

⑥Show Object Type

Displays the detected object type (human/vehicle/unknown) **in English** on the detection screen.

[Setting Value] On: Display object type/Off: Do not display object type

[Default] On: Display object type

⑦Show Movement Speed

[Setting Value] On: Display movement speed/Off: Do not display movement speed

[Default] On: Display movement speed

5.10.2 PTZ Linkage

5.10.2.1 Registered PTZ Cameras

Indicates the status of the PTZ connected to the instrument, including the Security Radar.

"IP Address", "Camera Name" and "Check Camera Connection" are displayed for each camera.

If the camera is successfully connected, the message "It was able to connect to the camera." appears.

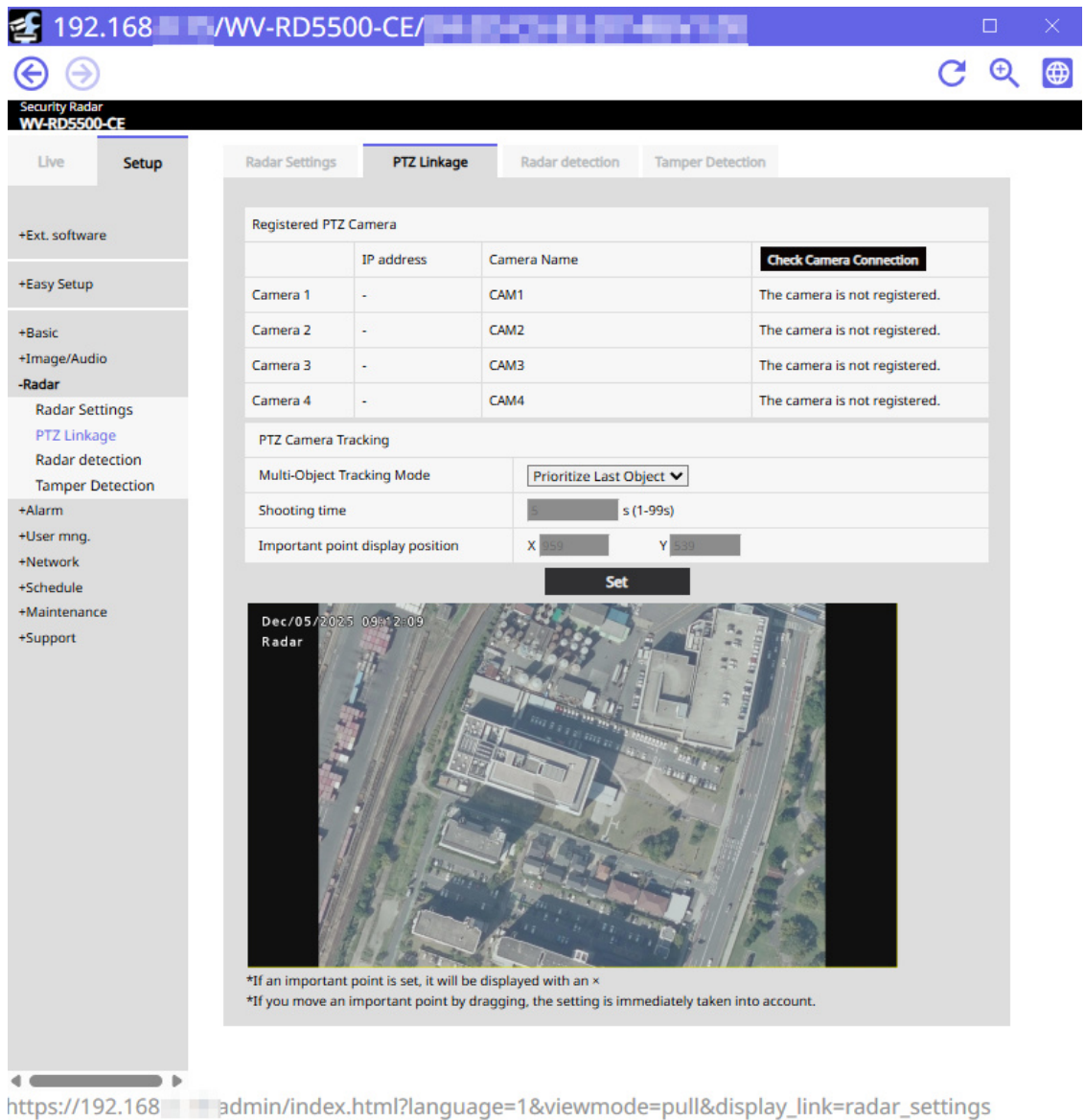

5.10.2.2 PTZ Camera Tracking

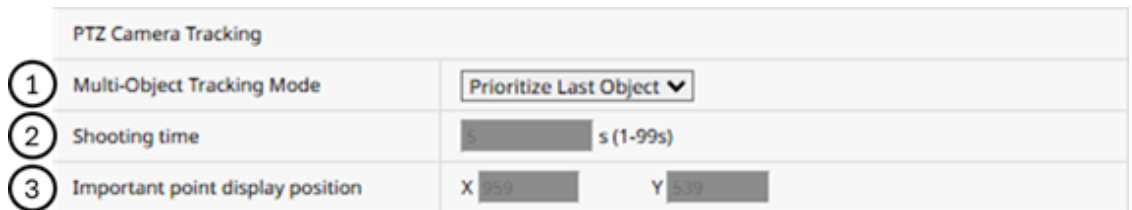

① Multi-Object Tracking Mode

Sets the operation mode for tracking several objects detected by Security Radar with PTZ cameras.

- Prioritize First Object: Prioritize the images in the alarm detection area in the order of first entry.

- **Prioritize Last Object:** Prioritize the images in the alarm detection area in the order of last entry.
- **Prioritize Key Points:** Prioritize the points in the order that they are close to the important points set in the Security Radar browser setting screen and radar → PTZ linkage, and then shoot them.
- **Capture All in Order:** All intruders in the alarm detection area are shot sequentially at regular intervals. (Recording time can be changed.)

[Setting Value] Prioritize First Object/Prioritize Last Object/Prioritize Key Points/Capture All in Order

[Default] Prioritize Last Object

② Shooting time

When "Multi-Object Tracking Mode" is set to "Capture All in Order", set the display time of each camera screen.

[Setting Value] 1 to 99 (s)

[Default] 5(s)

③ Important point display position

If "Multi-Object Tracking Mode" is set to "Prioritize Key Points", the part other than the setting area is turned Gray out. When you select Priority, an X mark is displayed on the screen to indicate the important point. You can set it by dragging the X mark in the map directly or by entering the coordinates.

[Setting Value] X: 0 to 1919 Y: 0 to 1079

[Default] X: 959 Y: 539

5.10.3 Radar Detection



[Notice]

For details on the Radar Detection settings, refer to the following.

→ [\[Radar detection\] for setting radar detection](#)

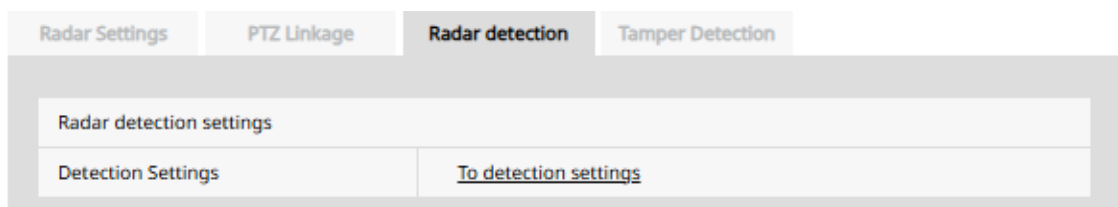

① Alarm detection area setting

Set the alarm detection and mask detection area, and select the detection object and detection mode.

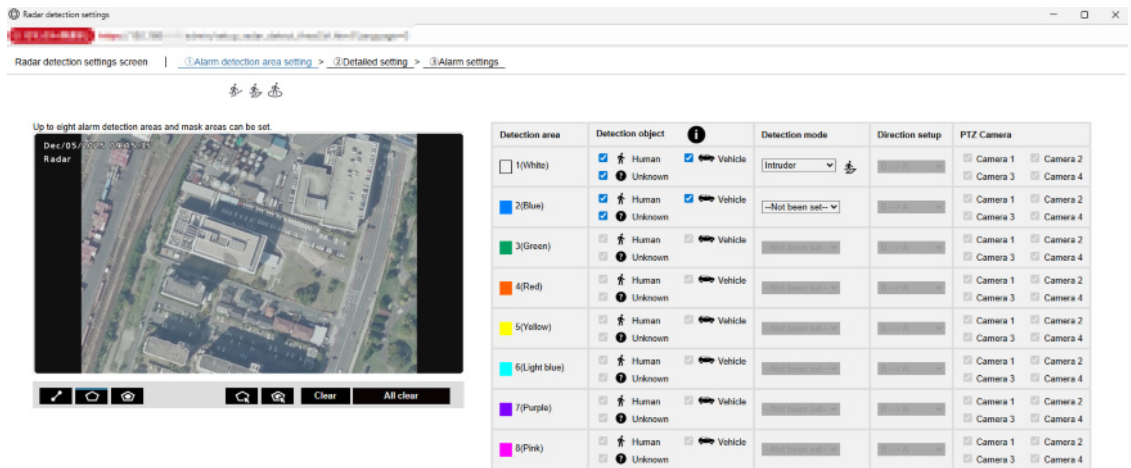

Set

Detection Object: Human, Vehicle, Unknown

Detection mode: Intruder, Loitering, Cross line

② Detailed setting

You can configure the details of each alarm detection.

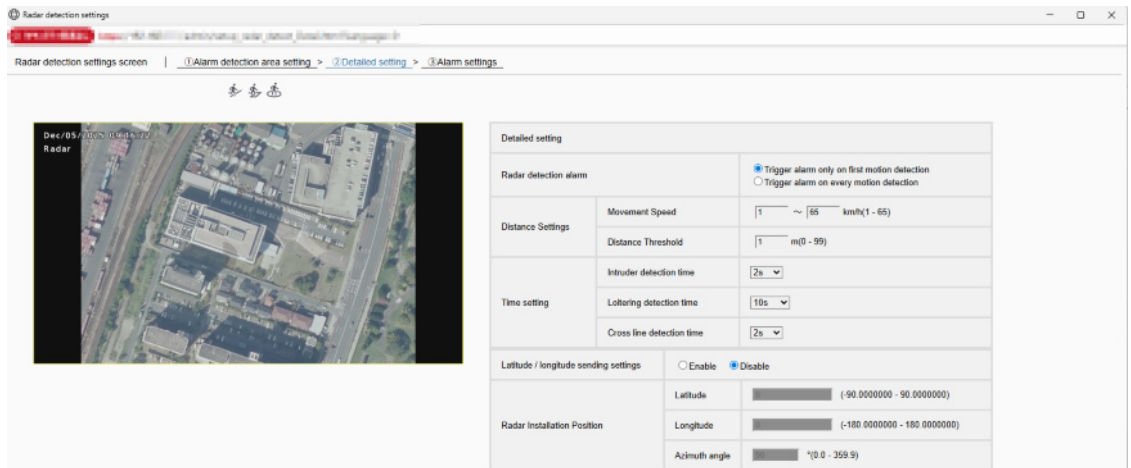

Set

③ Alarm settings

You can set the notification method for the alarm information.

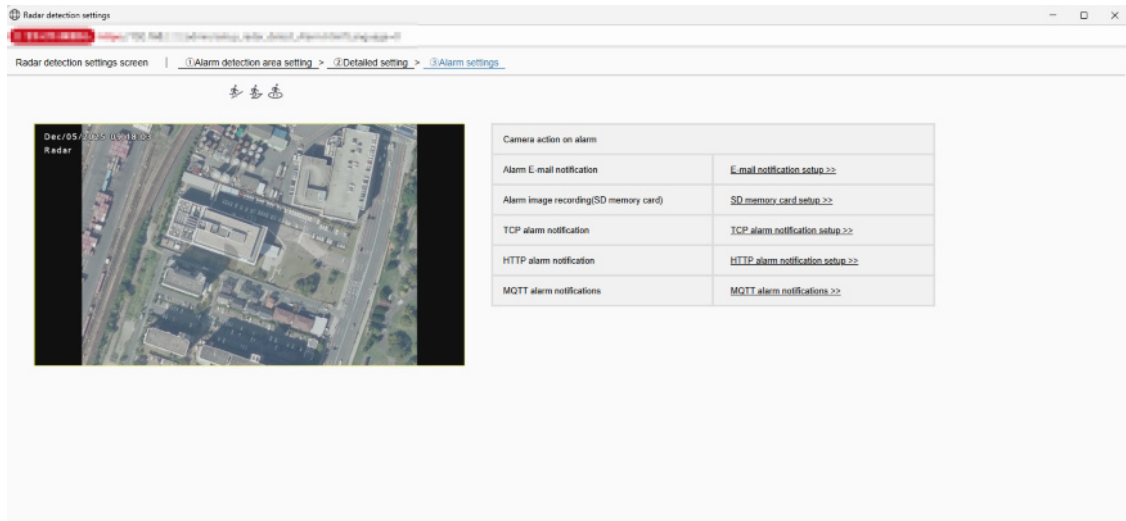

5.10.4 Tamper Detection

Configure the "Tamper Detection" function.

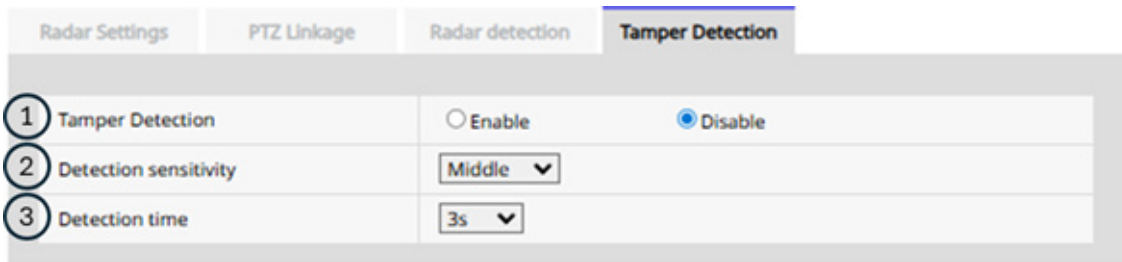

① Tamper Detection

Radar jamming is detected by an iron plate placed in front of the radar, and if unnatural detection points are concentrated at a short distance, it is judged that something interfering with the radar wave is placed, and a radar jamming detection alarm is issued.

[Setting Value] Enable/Disable

[Default] disabled

② Detection sensitivity

Specifies the sensitivity of the disturbance detection. The higher the sensitivity, the easier it is to generate an alert.

[Setting Value] Very Low/Low/Middle/High

[Default] Middle

③ Detection time

Generates an alarm when an interruption is detected continuously for a specified period of time.

The shorter the time, the easier it is to make a call.

[Setting Value] 3s/5s/10s/1min

[Default] 3s