

UL TEST REPORT AND PROCEDURE

Standard:	UL 62368-1, 3rd Ed, 2021-10-22 (Audio/video, information and communication technology equipment Part 1: Safety requirements) CAN/CSA C22.2 No. 62368-1:19, 3rd Ed, 2021-10-22 (Audio/video, information and communication technology equipment Part 1: Safety requirements)
Certification Type:	Listing
CCN:	AZOT, AZOT7 (Audio/video, Information and Communication Technology Equipment)
Complementary CCN:	N/A
Product:	Network Camera
Model:	1) WV-S8574L, WV-S8573L, WV-S8544L, WV-S8543L, WV-S8564L, WV-S8563L 2) WV-S8544, WV-S8543
Rating:	1) 54 V d.c.(PoE) 470 mA 2) 54 V d.c.(PoE) 320 mA
Applicant Name and Address:	I-PRO CO., LTD. 7-9-66 HAKOZAKI HIGASHI-KU FUKUOKA-SHI FUKUOKA 812-0053 JAPAN

This is to certify that representative samples of the products covered by this Test Report have been investigated in accordance with the above referenced Standards. The products have been found to comply with the requirements covering the category and the products are judged to be eligible for Follow-Up Service under the indicated Test Procedure. The manufacturer is authorized to use the UL Mark on such products which comply with this Test Report and any other applicable requirements of UL LLC ('UL') in accordance with the Follow-Up Service Agreement. Only those products which properly bear the UL Mark are considered as being covered by UL's Follow-Up Service under the indicated Test Procedure.

The applicant is authorized to reproduce the referenced Test Report provided it is reproduced in its entirety.

UL authorizes the applicant to reproduce the latest pages of the referenced Test Report consisting of the first page of the Specific Technical Criteria through to the end of the Conditions of Acceptability.

Any information and documentation involving UL Mark services are provided on behalf of UL LLC (UL) or any authorized licensee of UL.

Prepared By: Nao Maede / Project Handler

Reviewed By: Tadao Nakayama / Reviewer

Supporting Documentation

The following documents located at the beginning of this Procedure supplement the requirements of this Test Report:

A. Authorization - The Authorization page may include additional Factory Identification Code markings.

B. Generic Inspection Instructions -

- i. Part AC details important information which may be applicable to products covered by this Procedure. Products described in this Test Report must comply with any applicable items listed unless otherwise stated in the body of this Test Report.
- ii. Part AE details any requirements which may be applicable to all products covered by this Procedure. Products described in this Test Report must comply with any applicable items listed unless otherwise stated in the body of each Test Report.
- iii. Part AF details the requirements for the UL Certification Mark which is not controlled by the technical standard used to investigate these products. Products are permitted to bear only the Certification Mark(s) corresponding to the countries for which it is certified, as indicated in each Test Report.

Product Description

This product is a Network Camera for use in an outdoor environment.

This equipment is supplied from the External Power Supply.

External Power Supply : That External Power Supply itself is not evaluated in this report.

Model Differences

Refer to Enclosure Id: 07-01 for details of model differences.

WV-S8574L was used for test purposes and is considered representative of the entire series.

Test Item Particulars

Product group	end product
Classification of use by	Ordinary person Instructed person Skilled person
Supply Connection	not mains connected: ES1
Supply tolerance	None
Supply connection – type	External Power Supply
Considered current rating of protective device	N/A
Equipment mobility	stationary wall/ceiling-mounted
Over voltage category (OVC)	OVC II
Class of equipment	Class III
Special installation location	N/A
Pollution degree (PD)	PD 2
Manufacturer's specified T _{ma} (°C)	60
IP protection class	IP 66 / 67
Power systems	not AC mains
Altitude during operation (m)	2000 m or less
Altitude of test laboratory (m)	1000 m

Mass of equipment (kg)	3.3kg (Mode WV-S8574L, WV-S8544L, WV-S8564L, WV-S8544), 3.1kg (Model WV-S8573L, WV-S8543L, WV-S8563L, WV-S8543)
Additional Information Maximum normal load is continuous recording and LED lighting.	
Additional Standards The product fulfills the requirements of: UL 62368-1 3rd Edition, Issued December 13, 2019, CAN/CSA C22.2 No. 62368-1:19, 3rd Edition	
Markings and Instructions	
Clause Title	Marking or Instruction Details
Equipment identification marking – Manufacturer identification	Listee's or Recognized Company's name, Trade Name, Trademark or File Number
Equipment identification marking – model identification	Model Number
Equipment rating marking – ratings	Input Ratings (voltage, frequency/dc, current/power)
Special Instructions to UL Representative N/A	

BD1.0	TABLE: Production-Line Testing Requirements					
BD1.1	Electric Strength Test Special Constructions – Refer to Generic Inspection Instructions, Part AC for further information.					
Model	Component	Removable parts	Test probe location	Test V rms	Test V dc	Test Time, s
--	--	--	--	--	--	--
BD1.2	Earthing Continuity Test Exemptions – This test is not required for the following models:					
	All models					
BD1.3	Electric Strength Test Exemptions – This test is not required for the following models:					
	All models					
BD1.4	Electric Strength Test Component Exemptions – The following solid-state components may be disconnected from the remainder of the circuitry during the performance of this test.					
	N/A					

BE1.0	Sample and Test Specifics for Follow-Up Tests at UL				
Model	Component	Material	Test	Sample (s)	Test Specifics
--	--	--	--	--	--

4.1.2	TABLE: List of critical components					Pass
Object / part No.	Manufacturer/ trademark	Type / model	Technical data	Product Category CCN(s)	Mark(s) of conformity	Supplement ID
PoE Input Connector (JK901)	Dongguan Yuqiu Electronics Co., Ltd.	RJ011-FD08S3B1G10	AC150V, 0.5A	--	(Tested in equipment)	
Lithium Battery (B301)	Panasonic Corp.	BR-1225 or BR-1225A	3.0V, 48mAh, Maximum Abnormal Charging Current: 3.0mA	BBCV2	UL	
Alternative	POWER GLORY BATTERY TECH (HK) CO., LTD.	BR1225	3.0V, 48mAh, Maximum Abnormal Charging Current: 10mA	BBCV2	UL	
IR LED (D1301) for WV-S8574L, WV-S8573L, WV-S8564L, WV-S8563L, WV-S8544L, WV-S8543L [6 pcs.]	OSRAM OPTO SEMICONDUCTOR S GMBH	SFH4715AS	1500mA, 5.8W	--	(Tested in equipment)	
Lens Module for WV-S8544L, WV-S8544 [4 pcs.], WV-S8543L, WV-S8543 [3 pcs.]	Tamron Co., Ltd.	DF036L0010	Constructed with Focus motor, Zoom motor, D/N IR motor and Thermistor.	--	(Tested in equipment)	
Lens Module for WV-S8574L, WV-S8564L [4 pcs.], WV-S8573L, WV-S8563L [3 pcs.]	Konica Minolta, Inc.	ADVJ008	No motor included.	--	(Tested in equipment)	
D/N motor for WV-S8574L, WV-S8564L [4 pcs.], WV-S8573L, WV-S8563L [3 pcs.]	ShaanXi XuanYi Optic & Electronic CO., Ltd.	S113-P4	3.3V-7VDC, 25ohms	--	(Tested in equipment)	

PCBs	Interchangeable	Interchangeable	Minimum V-1, Minimum 130°C	ZPMV2	UL	
Flexible PCBs	Interchangeable	Interchangeable	Minimum V-1, Minimum 80°C	ZPXK2	UL	
Internal Wires	Interchangeable	Interchangeable	VW-1, Minimum 30V, Minimum 80°C	AVLV2	UL	
DOME LENS MULTI C	Mitsubishi Engineering - Plastic Corp.	S-2000VUR(f1)	Minimum 0.38mm thick, V-2	QMFZ2	UL	
Alternative	Interchangeable	Interchangeable	Minimum HB at thickness and color used.(Suitable for outdoor use with respect to exposure to Ultraviolet Light, Water Exposure and Immersion in accordance with UL 746C.)	QMFZ2	UL	
IR-LED COVER C for WV-S8574L, WV-S8573L, WV-S8564L, WV-S8563L, WV-S8544L, WV-S8543L	Mitsubishi Engineering - Plastic Corp.	S-2000UR(f1)	Minimum 0.38mm thick, V-2	QMFZ2	UL	
Alternative	Interchangeable	Interchangeable	Minimum HB at thickness and color used.(Suitable for outdoor use with respect to exposure to Ultraviolet Light, Water Exposure and Immersion in accordance with UL 746C.)	QMFZ2	UL	

IR-LED COVER W for WV-S8544, WV- S8543	Mitsubishi Engineering - Plastic Corp.	LN-3520ZH(f1)	Minimum 1.0mm thick, V-2	QMFZ2	UL	
Alternative	Interchangeable	Interchangeable	Minimum HB at thickness and color used.(Suitable for outdoor use with respect to exposure to Ultraviolet Light, Water Exposure and Immersion in accordance with UL 746C.)	QMFZ2	UL	
LENS COVER UPPER	Teijin Chemicals Plastic Compounds Shanghai Ltd.	LN-1250G	Minimum 1.0mm thick, V-0	QMFZ2	UL	
Alternative	Interchangeable	Interchangeable	Minimum HB at thickness used.	QMFZ2	UL	
LENS COVER LOWER	Teijin Chemicals Plastic Compounds Shanghai Ltd.	LN-1250G	Minimum 1.0mm thick, V-0	QMFZ2	UL	
Alternative	Interchangeable	Interchangeable	Minimum HB at thickness used.	QMFZ2	UL	
PAN BASE	Teijin Chemicals Plastic Compounds Shanghai Ltd.	LN-1250G	Minimum 1.0mm thick, V-0	QMFZ2	UL	
Alternative	Interchangeable	Interchangeable	Minimum HB at thickness used.	QMFZ2	UL	
PAN CHASSIS STOPPER	Teijin Chemicals Plastic Compounds Shanghai Ltd.	LN-1250G	Minimum 1.0mm thick, V-0	QMFZ2	UL	
Alternative	Interchangeable	Interchangeable	Minimum HB at thickness used.	QMFZ2	UL	

SD COVER	Teijin Chemicals Plastic Compounds Shanghai Ltd.	LN-1250G	Minimum 1.0mm thick, V-0	QMFZ2	UL	
Alternative	Interchangeable	Interchangeable	Minimum HB at thickness used.	QMFZ2	UL	
LAN COVER	Teijin Chemicals Plastic Compounds Shanghai Ltd.	LN-1250G	Minimum 1.0mm thick, V-0	QMFZ2	UL	
Alternative	Interchangeable	Interchangeable	Minimum HB at thickness used.	QMFZ2	UL	
PAN CHASSIS BASE	Teijin Chemicals Plastic Compounds Shanghai Ltd.	LN-1250G	Minimum 1.0mm thick, V-0	QMFZ2	UL	
Alternative	Interchangeable	Interchangeable	Minimum HB at thickness used.	QMFZ2	UL	
MULTI BASE SHEET	Shenzhen Teesun Technology Co., Ltd.	TS-FR1370	Minimum 0.25mm thick, V-0	QMFZ2	UL	
Alternative	Interchangeable	Interchangeable	Minimum V-0 at thickness used.	QMFZ2	UL	
FRAME BASE HOUSING	Interchangeable	ADC12	Aluminum	--	(Tested in equipment)	
MULTI BASE	Interchangeable	AISI10Mg	Aluminum alloy	--	(Tested in equipment)	
DOME PACKING	Dow Corning Toray Silicone Co., Ltd.	RBB-6650-50	Silicone, Black	QMFZ2	UL	
Alternative	JIANGSU PEARL SILICONE RUBBER MATERIAL CO., LTD.	HD-87XX (Hardness: 40)	Silicone, Black	QMFZ2	UL	
Alternative	JIANGSU PEARL SILICONE RUBBER	HD-87XX (Hardness: 50)	Silicone, Black	QMFZ2	UL	

	MATERIAL CO., LTD.					
Alternative	JIANGSU PEARL SILICONE RUBBER MATERIAL CO., LTD.	HD-87XX (Hardness: 60)	Silicone, Black	QMFZ2	UL	
GROMMET	Dow Corning Toray Silicone Co., Ltd.	RBB-6630-30	Silicone, Black	QMFZ2	UL	
Alternative	WYNCA TINYO SILICONE CO., LTD.	TY856 (Hardness: 30)	Silicone, Natural	QMFZ2	UL	
Alternate	WYNCA TINYO SILICONE CO., LTD.	TY856 (Hardness: 20)	Silicone, Natural	QMFZ2	UL	

Enclosures

Type	Supplement Id	Description
Photographs	03-01	Overall view_1
Photographs	03-02	Overall view_2
Photographs	03-03	Overall view_3
Photographs	03-04	Overall view_4
Photographs	03-05	Internal view
Photographs	03-06	PWB_1
Photographs	03-07	PWB_2
Schematics + PWB	05-01	Schematics for RTC and Temp Sensor circuits
Miscellaneous	07-01	Model Differences
Miscellaneous	07-02	IEC 62471 Test Report for AF LED
Miscellaneous	07-03	Marking Label



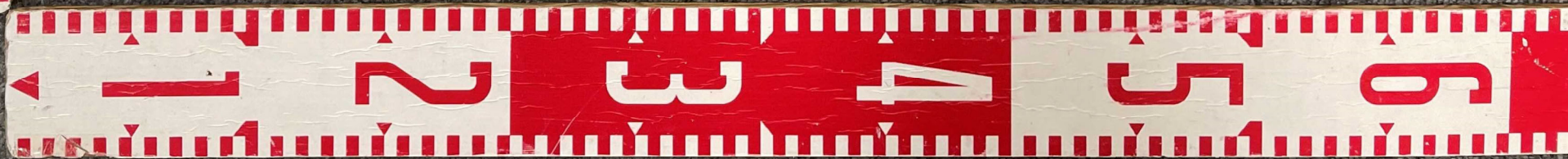

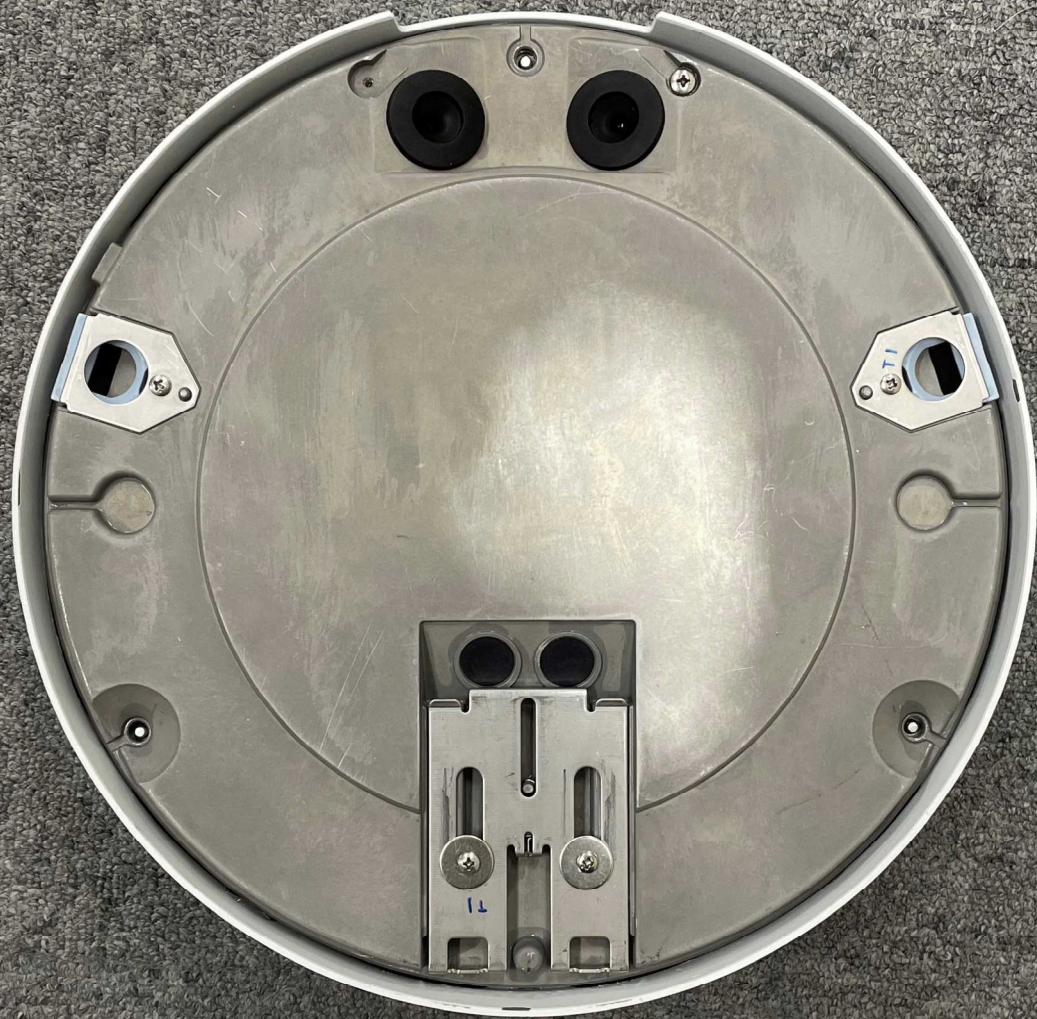



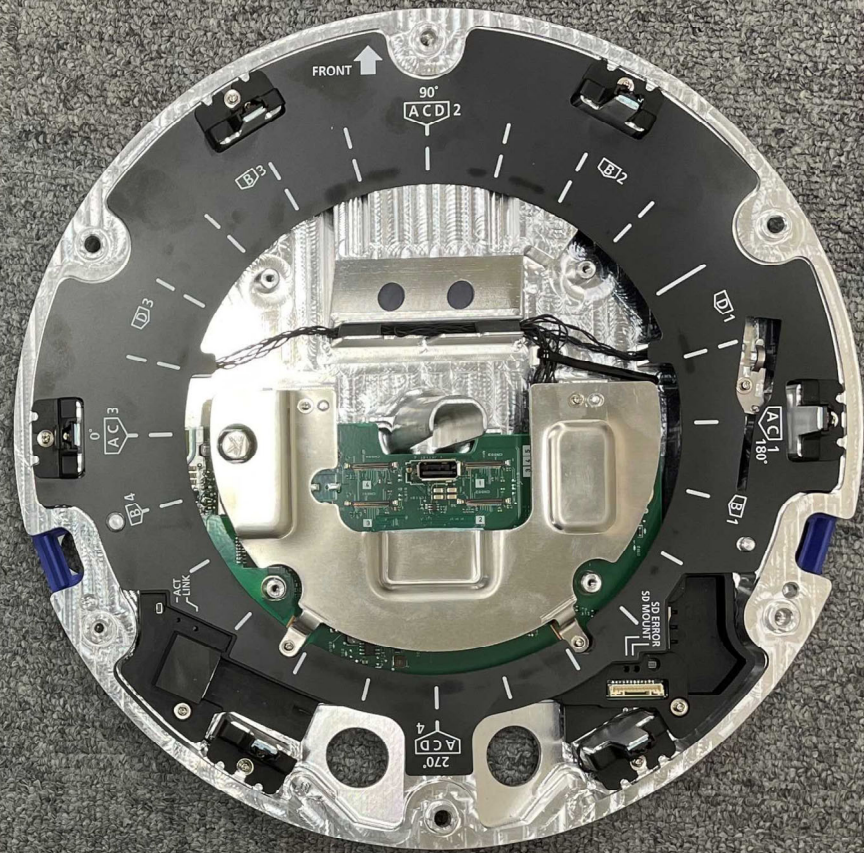

【RTC & Temp Sensor】

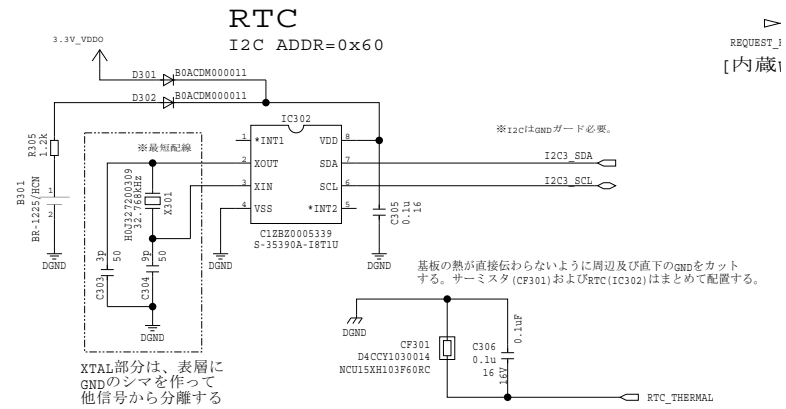



Model difference

Model	Pixel count	Number of Lenses	Zoom lens	IR-LED	Rating	Remarks
WV-S8574L	4K	4	No	Yes	PoE+ 54Vdc, 470mA	Basic model: Max power consumption
WV-S8573L	4K	3	No	Yes	PoE+ 54Vdc, 470mA	
WV-S8544L	4M	4	Yes	Yes	PoE+ 54Vdc, 470mA	
WV-S8543L	4M	3	Yes	Yes	PoE+ 54Vdc, 470mA	
WV-S8544	4M	4	Yes	No	PoE+ 54Vdc, 320mA	
WV-S8543	4M	3	Yes	No	PoE+ 54Vdc, 320mA	
WV-S8564L	6M	4	No	Yes	PoE+ 54Vdc, 470mA	
WV-S8563L	6M	3	No	Yes	PoE+ 54Vdc, 470mA	



TEST REPORT IEC 62471 Photobiological safety of lamps and lamp systems	
Report Reference No.	4790139303R
Date of issue	2021-12-10
Total number of pages	19 (plus 7 enclosure pages)
Name of Testing Laboratory preparing the Report	UL Japan, Inc.
Applicant's name	Panasonic i-PRO Sensing Solutions Co., Ltd.
Address	1-62, 4-chome, Minoshima, Hakata-ku, Fukuoka 812-8531 Japan
Test specification:	
Standard	IEC 62471:2006
Test procedure	Informative
Non-standard test method	N/A
Test Report Form No.	IEC62471B
TRF Originator	VDE Testing and Certification Institute
Master TRF	Dated 2018-08-16
Copyright © 2018 IEC System for Conformity Testing and Certification of Electrical Equipment (IECEE), Geneva, Switzerland. All rights reserved. This publication may be reproduced in whole or in part for non-commercial purposes as long as the IECEE is acknowledged as copyright owner and source of the material. IECEE takes no responsibility for and will not assume liability for damages resulting from the reader's interpretation of the reproduced material due to its placement and context. If this Test Report Form is used by non-IECEE members, the IECEE/IEC logo and the reference to the CB Scheme procedure shall be removed.	
This report is not valid as a CB Test Report unless signed by an approved CB Testing Laboratory and appended to a CB Test Certificate issued by an NCB in accordance with IECEE 02.	
General disclaimer:	
The test results presented in this report relate only to the object tested. This report shall not be reproduced, except in full, without the written approval of the Issuing CB Testing Laboratory. The authenticity of this Test Report and its contents can be verified by contacting the NCB, responsible for this Test Report.	

Test item description	Network Camera	
Trade Mark	Panasonic	
Manufacturer	Panasonic i-PRO Sensing Solutions Co., Ltd. 1-62, 4-chome, Minoshima, Hakata-ku, Fukuoka 812-8531 Japan	
Model/Type reference	WV-S8574L, WV-S8573L, WV-S8544L, WV-S8543L, WV-S8564L, WV-S8563L	
Ratings	POWER PoE+ 54 Vdc, 470mA (Class 4)	
Responsible Testing Laboratory (as applicable), testing procedure and testing location(s):		
<input checked="" type="checkbox"/>	CB Testing Laboratory:	
Testing location/ address	UL Japan Inc. 4383-326 Asama-cho, Ise-shi, Mie 516-0021 Japan	
Tested by (name, function, signature)	Chikako Matsuoka (Project Handler)	
Approved by (name, function, signature) ..	Hiroaki Ueda (Reviewer)	
<input type="checkbox"/>	Testing procedure: CTF Stage 1:	
Testing location/ address	N/A	
Tested by (name, function, signature)	N/A	
Approved by (name, function, signature) ..	N/A	
<input type="checkbox"/>	Testing procedure: CTF Stage 2:	
Testing location/ address	N/A	
Tested by (name + signature)	N/A	
Witnessed by (name, function, signature) ..	N/A	
Approved by (name, function, signature) ..	N/A	
<input type="checkbox"/>	Testing procedure: CTF Stage 3:	
<input type="checkbox"/>	Testing procedure: CTF Stage 4:	
Testing location/ address	N/A	
Tested by (name, function, signature)	N/A	
Witnessed by (name, function, signature) ..	N/A	
Approved by (name, function, signature) ..	N/A	
Supervised by (name, function, signature) :	N/A	

List of Attachments (including a total number of pages in each attachment): This report contains the following enclosure pages. <ul style="list-style-type: none">• Enclosure 1 - ADDITIONAL INFORMATION ON TEST RESULTS (3 pages)• Enclosure 2 - PHOTOGRAPHS (2 pages)• Enclosure 3 - EUROPEAN GROUP DIFFERENCES AND NATIONAL DIFFERENCES (2 pages)	
Summary of testing:	
Tests performed (name of test and test clause): The product was tested and classified according to the following clauses. <ul style="list-style-type: none">• Clause 4: Exposure Limits (EL's)• Clause 5: Measurement of Lamps and Lamp Systems• Clause 6: Lamp Classification For further information, see general product information and other remarks for details.	Testing location: UL Japan, Inc. 4383-326 Asama-cho, Ise-shi, Mie 516-0021 Japan
Summary of compliance with National Differences (List of countries addressed): The product was evaluated for CENELEC Common Modification (corresponding to EN62471: 2008). The radiation of the product was assigned as Exempt Group. See Enclosure 3.	

Copy of marking plate:

The artwork below may be only a draft. The use of certification marks on a product must be authorized by the respective NCBs that own these marks.

i-PRO

Network Camera
ネットワークカメラ
Model No. WV-S8574L
POWER PoE+ 54 V = 470 mA
(Class4)
i-PRO Co., Ltd. Engineered in Japan
Made in China

UKCA i-PRO Co., Ltd, Fukuoka, Japan
i-PRO EMEA B.V. UK Branch
1010 Cambourne Business Park,
Cambridgeshire CB23 6DP

CE i-PRO Co., Ltd, Fukuoka, Japan
Authorised Representative in EU:
i-PRO EMEA B.V.
Laarderhoogtweg 25,
1101 EB Amsterdam,
Netherlands

FCC

IP66/IP67
TYPE 4X
ENCLOSURE

CAN ICES-3 (A)/NMB-3(A)

THIS DEVICE COMPLIES WITH PART 15 OF THE FCC RULES. OPERATION IS SUBJECT TO THE FOLLOWING TWO CONDITIONS: (1) THIS DEVICE MAY NOT CAUSE HARMFUL INTERFERENCE, AND (2) THIS DEVICE MUST ACCEPT ANY INTERFERENCE RECEIVED, INCLUDING INTERFERENCE THAT MAY CAUSE UNDESIRE OPERATION.

この装置は、クラスA機器です。この装置を住宅環境で使用すると電波妨害を引き起こすことがあります。この場合には使用者が適切な対策を講ずるよう要求されることがあります。 VCCI-A

For model WV-S8574L

i-PRO

Network Camera
ネットワークカメラ
Model No. WV-S8573L
POWER PoE+ 54 V = 470 mA
(Class4)
i-PRO Co., Ltd. Engineered in Japan
Made in China

UKCA i-PRO Co., Ltd, Fukuoka, Japan
i-PRO EMEA B.V. UK Branch
1010 Cambourne Business Park,
Cambridgeshire CB23 6DP

CE i-PRO Co., Ltd, Fukuoka, Japan
Authorised Representative in EU:
i-PRO EMEA B.V.
Laarderhoogtweg 25,
1101 EB Amsterdam,
Netherlands

FCC

IP66/IP67
TYPE 4X
ENCLOSURE

CAN ICES-3 (A)/NMB-3(A)

THIS DEVICE COMPLIES WITH PART 15 OF THE FCC RULES. OPERATION IS SUBJECT TO THE FOLLOWING TWO CONDITIONS: (1) THIS DEVICE MAY NOT CAUSE HARMFUL INTERFERENCE, AND (2) THIS DEVICE MUST ACCEPT ANY INTERFERENCE RECEIVED, INCLUDING INTERFERENCE THAT MAY CAUSE UNDESIRE OPERATION.

この装置は、クラスA機器です。この装置を住宅環境で使用すると電波妨害を引き起こすことがあります。この場合には使用者が適切な対策を講ずるよう要求されることがあります。 VCCI-A

For model WV-S8573L

i-PRO 

Network Camera
ネットワークカメラ
Model No. **WV-S8564L**
POWER PoE+ 54 V = 470 mA
(Class4)

i-PRO Co., Ltd. Engineered in Japan
Made in China **CULUS**

UK CA CE i-PRO Co., Ltd, Fukuoka, Japan
i-PRO EMEA B.V. UK Branch
1010 Cambourne Business Park,
Cambridgeshire CB23 6DP
i-PRO Co., Ltd, Fukuoka, Japan
Authorised Representative in EU:
i-PRO EMEA B.V.
Laarderhoogweg 25,
1101 EP Amsterdam,
Netherlands

IP66/IP67
TYPE 4X
ENCLOSURE

CAN ICES-3 (A)/NMB-3(A)

THIS DEVICE COMPLIES WITH PART 15 OF THE FCC RULES. OPERATION IS SUBJECT TO THE FOLLOWING TWO CONDITIONS: (1) THIS DEVICE MAY NOT CAUSE HARMFUL INTERFERENCE, AND (2) THIS DEVICE MUST ACCEPT ANY INTERFERENCE RECEIVED, INCLUDING INTERFERENCE THAT MAY CAUSE UNDESIRE OPERATION.

この装置は、クラスA 機器です。この装置を住宅環境で使用すると電波妨害を引き起こすことがあります。この場合には使用者が適切な対策を講ずるよう要求されることがあります。 VCCI-A

For model WV-S8564L

i-PRO 

Network Camera
ネットワークカメラ
Model No. **WV-S8563L**
POWER PoE+ 54 V = 470 mA
(Class4)

i-PRO Co., Ltd. Engineered in Japan
Made in China **CULUS**

UK CA CE i-PRO Co., Ltd, Fukuoka, Japan
i-PRO EMEA B.V. UK Branch
1010 Cambourne Business Park,
Cambridgeshire CB23 6DP
i-PRO Co., Ltd, Fukuoka, Japan
Authorised Representative in EU:
i-PRO EMEA B.V.
Laarderhoogweg 25,
1101 EP Amsterdam,
Netherlands

IP66/IP67
TYPE 4X
ENCLOSURE

CAN ICES-3 (A)/NMB-3(A)

THIS DEVICE COMPLIES WITH PART 15 OF THE FCC RULES. OPERATION IS SUBJECT TO THE FOLLOWING TWO CONDITIONS: (1) THIS DEVICE MAY NOT CAUSE HARMFUL INTERFERENCE, AND (2) THIS DEVICE MUST ACCEPT ANY INTERFERENCE RECEIVED, INCLUDING INTERFERENCE THAT MAY CAUSE UNDESIRE OPERATION.

この装置は、クラスA 機器です。この装置を住宅環境で使用すると電波妨害を引き起こすことがあります。この場合には使用者が適切な対策を講ずるよう要求されることがあります。 VCCI-A

For model WV-S8563L

i-PRO 

Network Camera
ネットワークカメラ
Model No. **WV-S8544L**
POWER PoE+ 54 V = 470 mA
(Class4)

i-PRO Co., Ltd. Engineered in Japan
Made in China **C UL US**

UK CA CE i-PRO Co., Ltd, Fukuoka, Japan
i-PRO EMEA B.V. UK Branch
1010 Cambourne Business Park,
Cambridgeshire CB23 6DP
i-PRO Co., Ltd, Fukuoka, Japan
Authorised Representative in EU:
i-PRO EMEA B.V.
Laarderhoogweg 25,
1101 EB Amsterdam,
Netherlands

LISTED
L.T.E. E521573

FC 

IP66/IP67
TYPE 4X ENCLOSURE

CAN ICES-3 (A)/NMB-3(A)

THIS DEVICE COMPLIES WITH PART 15 OF THE FCC RULES. OPERATION IS SUBJECT TO THE FOLLOWING TWO CONDITIONS: (1) THIS DEVICE MAY NOT CAUSE HARMFUL INTERFERENCE, AND (2) THIS DEVICE MUST ACCEPT ANY INTERFERENCE RECEIVED, INCLUDING INTERFERENCE THAT MAY CAUSE UNDESIRE OPERATION.

この装置は、クラスA 機器です。この装置を住宅環境で使用すると電波妨害を引き起こすことがあります。この場合には使用者が適切な対策を講ずるよう要求されることがあります。 VCCI-A

For model WV-S8544L

i-PRO 

Network Camera
ネットワークカメラ
Model No. **WV-S8543L**
POWER PoE+ 54 V = 470 mA
(Class4)

i-PRO Co., Ltd. Engineered in Japan
Made in China **C UL US**

UK CA CE i-PRO Co., Ltd, Fukuoka, Japan
i-PRO EMEA B.V. UK Branch
1010 Cambourne Business Park,
Cambridgeshire CB23 6DP
i-PRO Co., Ltd, Fukuoka, Japan
Authorised Representative in EU:
i-PRO EMEA B.V.
Laarderhoogweg 25,
1101 EB Amsterdam,
Netherlands

LISTED
L.T.E. E521573

FC 

IP66/IP67
TYPE 4X ENCLOSURE

CAN ICES-3 (A)/NMB-3(A)

THIS DEVICE COMPLIES WITH PART 15 OF THE FCC RULES. OPERATION IS SUBJECT TO THE FOLLOWING TWO CONDITIONS: (1) THIS DEVICE MAY NOT CAUSE HARMFUL INTERFERENCE, AND (2) THIS DEVICE MUST ACCEPT ANY INTERFERENCE RECEIVED, INCLUDING INTERFERENCE THAT MAY CAUSE UNDESIRE OPERATION.

この装置は、クラスA 機器です。この装置を住宅環境で使用すると電波妨害を引き起こすことがあります。この場合には使用者が適切な対策を講ずるよう要求されることがあります。 VCCI-A

For model WV-S8543L

Test item particulars: See below.	
Tested lamp	<input checked="" type="checkbox"/> continuous wave lamps <input type="checkbox"/> pulsed lamps
Tested lamp system	See General product information and other remarks.
Lamp classification group	<input checked="" type="checkbox"/> exempt <input type="checkbox"/> risk 1 <input type="checkbox"/> risk 2 <input type="checkbox"/> risk 3
Lamp cap	N/A
Bulb	N/A
Rated of the lamp	See General product information and other remarks.
Furthermore marking on the lamp.....	N/A – Exempt Group
Seasoning of lamps according IEC standard	N/A -LED
Used measurement instrument.....	Spectroradiometer System, Beam Profiler, etc.
Temperature by measurement.....	See Enclosure 1.
Information for safety use	N/A – Exempt Group
Possible test case verdicts:	
– test case does not apply to the test object: N/A	
– test object does meet the requirement	
– test object does not meet the requirement: F (Fail)	
Testing:	
Date of receipt of test item	2021-10-29
Date (s) of performance of tests	2021-11-26
General remarks:	
"(See Enclosure #)" refers to additional information appended to the report. "(See appended table)" refers to a table appended to the report. Throughout this report a <input type="checkbox"/> comma / <input checked="" type="checkbox"/> point is used as the decimal separator.	
Manufacturer’s Declaration per sub-clause 4.2.5 of IEC60529:	
The application for obtaining a CB Test Certificate includes more than one factory location and a declaration from the Manufacturer stating that the sample(s) submitted for evaluation is (are) representative of the products from each factory has been provided:	<input type="checkbox"/> Yes <input checked="" type="checkbox"/> Not applicable

When differences exist; they shall be identified in the General product information section.

Name and address of factory (ies)..... : PANASONIC CORPORATION
 1471 Murata-Machi, Tosu-Shi, Saga 841-8501
 JAPAN

PANASONIC SYSTEM NETWORKS (SUZHOU)
 CO., LTD.
 1478 BINGHE RD. NEW DISTRICT, SUZHOU
 JIANGSU CHINA

SVI (AEC) COMPANY LIMITED
 Phnom Penh Special Economic Zone, Lot P2-063,
 064 PPSEZ, National Road No. 4, Sangkat Boeng
 Thom, Khan Por Senchey, Phnom Penh 120907 KH

Kumamoto Techno Corporation
 920-29, Toshima-machi, Higashi-ku, Kumamoto-shi,
 Kumamoto 861-8031, Japan

General product information and other remarks:

<Product Description>

This product is a network camera employing six IR LEDs. The product is intended for non-GLS use.

<LED Information>

- Mfr.: OSRAM Opto Semiconductors GmbH
- Type: SFH 4715AS
- Ratings:
 - Maximum Rating Forward current (I_F): max. 1500mA
 - Peak Wavelength: typ. 860nm
 - Radiant intensity: typ. 900 mW/sr (@ I_F = 1000mA; t_p = 10 ms)

<Model Difference>

Model WV-S8574L is basic model.

Models WV-S8573L, WV-S8544L, WV-S8543L, WV-S8564L, WV-S8563L are identical to model WV-S8574L except for the following differences.

Model	Number of pixel	Number of lens	Zoom lens
WV-S8574L	4K	4	No
WV-S8573L	4K	3	No
WV-S8544L	4M	4	Yes
WV-S8543L	4M	3	Yes
WV-S8564L	6M	4	No
WV-S8563L	6M	3	No

These differences do not affect optical radiation.

<Report Summary>

This is a new test report.

Testing was conducted on a test sample of model WV-S8574L as representative of all the models. For details, see appended table 6.1 and Enclosure 1.

When the optical characteristic of the LED or any optical component is changed, re-measurement or further consideration should be necessary.

IEC 62471			
Clause	Requirement + Test	Result – Remark	Verdict
4	EXPOSURE LIMITS		P
4.1	General		P
	The exposure limits in this standard is not less than 0,01 ms and not more than any 8-hour period and should be used as guides in the control of exposure	The product was assessed for continuous wave (CW) emission. See ENCLOSURE 1	P
	Detailed spectral data of a light source are generally required only if the luminance of the source exceeds $10^4 \text{ cd}\cdot\text{m}^{-2}$	see clause 4.3	P
4.3	Hazard exposure limits		P
4.3.1	Actinic UV hazard exposure limit for the skin and eye	The source does not emit in wavelength range 200-400nm.	N/A
	The exposure limit for effective radiant exposure is $30 \text{ J}\cdot\text{m}^{-2}$ within any 8-hour period		N/A
	To protect against injury of the eye or skin from ultraviolet radiation exposure produced by a broadband source, the effective integrated spectral irradiance, E_s , of the light source shall not exceed the levels defined by:		N/A
	$E_s \cdot t = \sum_{200}^{400} \sum_t E_\lambda(\lambda, t) \cdot S_{UV}(\lambda) \cdot \Delta t \cdot \Delta \lambda \leq 30 \quad \text{J}\cdot\text{m}^{-2}$		N/A
	The permissible time for exposure to ultraviolet radiation incident upon the unprotected eye or skin shall be computed by:		N/A
	$t_{\max} = \frac{30}{E_s} \quad \text{s}$		N/A
4.3.2	Near-UV hazard exposure limit for eye		N/A
	For the spectral region 315 nm to 400 nm (UV-A) the total radiant exposure to the eye shall not exceed $10000 \text{ J}\cdot\text{m}^{-2}$ for exposure times less than 1000 s. For exposure times greater than 1000 s (approximately 16 minutes) the UV-A irradiance for the unprotected eye, E_{UVA} , shall not exceed $10 \text{ W}\cdot\text{m}^{-2}$.	The source does not emit in wavelength range 315-400nm.	N/A
	The permissible time for exposure to ultraviolet radiation incident upon the unprotected eye for time less than 1000 s, shall be computed by:		N/A
	$t_{\max} \leq \frac{10\,000}{E_{UVA}} \quad \text{s}$		N/A
4.3.3	Retinal blue light hazard exposure limit		N/A
	To protect against retinal photochemical injury from chronic blue-light exposure, the integrated spectral radiance of the light source weighted against the blue-light hazard function, $B(\lambda)$, i.e., the blue-light weighted radiance, L_B , shall not exceed the levels defined by:	The source does not emit in wavelength range 300-700nm.	N/A

IEC 62471			
Clause	Requirement + Test	Result – Remark	Verdict
	$L_B \cdot t = \sum_{300}^{700} \sum_t L_\lambda(\lambda, t) \cdot B(\lambda) \cdot \Delta\lambda \leq 10^6 \quad \text{J} \cdot \text{m}^{-2} \cdot \text{sr}^{-1}$	for $t \leq 10^4$ s $t_{\max} = \frac{10^6}{L_B}$	N/A
	$L_B = \sum_{300}^{700} L_\lambda \cdot B(\lambda) \cdot \Delta\lambda \leq 100 \quad \text{W} \cdot \text{m}^{-2} \cdot \text{sr}^{-1}$	for $t > 10^4$ s	N/A
4.3.4	Retinal blue light hazard exposure limit - small source		N/A
	Thus the spectral irradiance at the eye E_λ , weighted against the blue-light hazard function $B(\lambda)$ shall not exceed the levels defined by:	The source does not emit in wavelength range 300-700nm.	N/A
	$E_B \cdot t = \sum_{300}^{700} \sum_t E_\lambda(\lambda, t) \cdot B(\lambda) \cdot \Delta\lambda \leq 100 \quad \text{J} \cdot \text{m}^{-2}$	for $t \leq 100$ s	N/A
	$E_B = \sum_{300}^{700} E_\lambda \cdot B(\lambda) \cdot \Delta\lambda \leq 1 \quad \text{W} \cdot \text{m}^{-2}$	for $t > 100$ s	N/A
4.3.5	Retinal thermal hazard exposure limit		P
	To protect against retinal thermal injury, the integrated spectral radiance of the light source, L_λ , weighted by the burn hazard weighting function $R(\lambda)$ (from Figure 4.2 and Table 4.2), i.e., the burn hazard weighted radiance, shall not exceed the levels defined by:	See appended table 6.1	P
	$L_R = \sum_{380}^{1400} L_\lambda \cdot R(\lambda) \cdot \Delta\lambda \leq \frac{50\,000}{\alpha \cdot t^{0,25}} \quad \text{W} \cdot \text{m}^{-2} \cdot \text{sr}^{-1}$	($10 \mu\text{s} \leq t \leq 10$ s)	P
4.3.6	Retinal thermal hazard exposure limit – weak visual stimulus		N/A
	For an infrared heat lamp or any near-infrared source where a weak visual stimulus is inadequate to activate the aversion response, the near infrared (780 nm to 1400 nm) radiance, L_{IR} , as viewed by the eye for exposure times greater than 10 s shall be limited to:	See appended table 6.1	N/A
	$L_{IR} = \sum_{780}^{1400} L_\lambda \cdot R(\lambda) \cdot \Delta\lambda \leq \frac{6\,000}{\alpha} \quad \text{W} \cdot \text{m}^{-2} \cdot \text{sr}^{-1}$	$t > 10$ s	N/A
4.3.7	Infrared radiation hazard exposure limits for the eye		P
	The avoid thermal injury of the cornea and possible delayed effects upon the lens of the eye (cataractogenesis), ocular exposure to infrared radiation, E_{IR} , over the wavelength range 780 nm to 3000 nm, for times less than 1000 s, shall not exceed:	See appended table 6.1	P
	$E_{IR} = \sum_{780}^{3000} E_\lambda \cdot \Delta\lambda \leq 18\,000 \cdot t^{-0,75} \quad \text{W} \cdot \text{m}^{-2}$	$t \leq 1000$ s	N/A
	For times greater than 1000 s the limit becomes:		P
	$E_{IR} = \sum_{780}^{3000} E_\lambda \cdot \Delta\lambda \leq 100 \quad \text{W} \cdot \text{m}^{-2}$	$t > 1000$ s	P
4.3.8	Thermal hazard exposure limit for the skin		P

IEC 62471			
Clause	Requirement + Test	Result – Remark	Verdict
	Visible and infrared radiant exposure (380 nm to 3000 nm) of the skin shall be limited to:		P
	$E_H \cdot t = \sum_{380}^{3000} \sum_t E_\lambda(\lambda, t) \cdot \Delta t \cdot \Delta \lambda \leq 20\,000 \cdot t^{0.25} \quad \text{J} \cdot \text{m}^{-2}$	See appended table 6.1 – footnote.	P
5	MEASUREMENT OF LAMPS AND LAMP SYSTEMS		P
5.1	Measurement conditions		P
	Measurement conditions shall be reported as part of the evaluation against the exposure limits and the assignment of risk classification.	Considered.	P
5.1.1	Lamp ageing (seasoning)		N/A
	Seasoning of lamps shall be done as stated in the appropriate IEC lamp standard.	Not required.	N/A
5.1.2	Test environment		P
	For specific test conditions, see the appropriate IEC lamp standard or in absence of such standards, the appropriate national standards or manufacturer's recommendations.	See Enclosure 1.	P
5.1.3	Extraneous radiation		P
	Careful checks should be made to ensure that extraneous sources of radiation and reflections do not add significantly to the measurement results.	Considered.	P
5.1.4	Lamp operation		N/A
	Operation of the test lamp shall be provided in accordance with:	N/A – Lamp system. See sub-clause 5.1.5.	N/A
	– the appropriate IEC lamp standard, or		N/A
	– the manufacturer's recommendation		N/A
5.1.5	Lamp system operation		P
	The power source for operation of the test lamp shall be provided in accordance with:		P
	– the appropriate IEC standard, or		N/A
	– the manufacturer's recommendation	Operated per the manufacturer's recommendation.	P
5.2	Measurement procedure		P
5.2.1	Irradiance measurements		P
	Minimum aperture diameter 7mm.	Circular aperture of 7mm diameter was used for spectral irradiance measurement.	P
	Maximum aperture diameter 50 mm.		P
	The measurement shall be made in that position of the beam giving the maximum reading.	Considered.	P
	The measurement instrument is adequate calibrated.		P

IEC 62471			
Clause	Requirement + Test	Result – Remark	Verdict
5.2.2	Radiance measurements		P
5.2.2.1	Standard method		P
	The measurements made with an optical system.		P
	The instrument shall be calibrated to read in absolute radiant power per unit receiving area and per unit solid angle to acceptance averaged over the field of view of the instrument.		P
5.2.2.2	Alternative method	Standard method was used. See sub-clause 5.2.2.1.	N/A
	Alternatively to an imaging radiance set-up, an irradiance measurement set-up with a circular field stop placed at the source can be used to perform radiance measurements.		N/A
5.2.3	Measurement of source size		P
	The determination of α , the angle subtended by a source, requires the determination of the 50% emission points of the source.	See Enclosure 1.	P
5.2.4	Pulse width measurement for pulsed sources	CW operation.	N/A
	The determination of Δt , the nominal pulse duration of a source, requires the determination of the time during which the emission is > 50% of its peak value.		N/A
5.3	Analysis methods		P
5.3.1	Weighting curve interpolations		P
	To standardize interpolated values, use linear interpolation on the log of given values to obtain intermediate points at the wavelength intervals desired.	Considered.	P
5.3.2	Calculations		P
	The calculation of source hazard values shall be performed by weighting the spectral scan by the appropriate function and calculating the total weighted energy.	Considered.	P
5.3.3	Measurement uncertainty		P
	The quality of all measurement results must be quantified by an analysis of the uncertainty.		P
6	LAMP CLASSIFICATION		P
	For the purposes of this standard it was decided that the values shall be reported as follows:		P
	– for lamps intended for general lighting service, the hazard values shall be reported as either irradiance or radiance values at a distance which produces an illuminance of 500 lux, but not at a distance less than 200 mm	Non-general lighting service.	N/A
	– for all other light sources, including pulsed lamp sources, the hazard values shall be reported at a distance of 200 mm	Considered.	P

IEC 62471			
Clause	Requirement + Test	Result – Remark	Verdict
6.1	Continuous wave lamps		P
6.1.1	Exempt Group		P
	In the exempt group are lamps, which does not pose any photobiological hazard. The requirement is met by any lamp that does not pose:	The radiation from the product was assigned as Exempt Group. See appended table 6.1	P
	– an actinic ultraviolet hazard (E_s) within 8-hours exposure (30000 s), nor		N/A
	– a near-UV hazard (E_{UVA}) within 1000 s, (about 16 min), nor		N/A
	– a retinal blue-light hazard (L_B) within 10000 s (about 2.8 h), nor		N/A
	– a retinal thermal hazard (L_R) within 10 s, nor	Not exceeded.	P
	– an infrared radiation hazard for the eye (E_{IR}) within 1000 s	Not exceeded.	P
6.1.2	Risk Group 1 (Low-Risk)		N/A
	In this group are lamps, which exceeds the limits for the exempt group but that does not pose:	See appended table 6.1	N/A
	– an actinic ultraviolet hazard (E_s) within 10000 s, nor		N/A
	– a near ultraviolet hazard (E_{UVA}) within 300 s, nor		N/A
	– a retinal blue-light hazard (L_B) within 100 s, nor		N/A
	– a retinal thermal hazard (L_R) within 10 s, nor		N/A
	– an infrared radiation hazard for the eye (E_{IR}) within 100 s		N/A
	Lamps that emit infrared radiation without a strong visual stimulus and do not pose a near-infrared retinal hazard (L_{IR}), within 100 s are in Risk Group 1.	Non-weak visual stimulus.	N/A
6.1.3	Risk Group 2 (Moderate-Risk)		N/A
	This requirement is met by any lamp that exceeds the limits for Risk Group 1, but that does not pose:	See appended table 6.1	N/A
	– an actinic ultraviolet hazard (E_s) within 1000 s exposure, nor		N/A
	– a near ultraviolet hazard (E_{UVA}) within 100 s, nor		N/A
	– a retinal blue-light hazard (L_B) within 0.25 s (aversion response), nor		N/A
	– a retinal thermal hazard (L_R) within 0.25 s (aversion response), nor		N/A
	– an infrared radiation hazard for the eye (E_{IR}) within 10 s		N/A
	Lamps that emit infrared radiation without a strong visual stimulus and do not pose a near-infrared retinal hazard (L_{IR}), within 10 s are in Risk Group 2.		N/A
6.1.4	Risk Group 3 (High-Risk)		N/A

IEC 62471			
Clause	Requirement + Test	Result – Remark	Verdict
	Lamps which exceed the limits for Risk Group 2 are in Group 3.	See appended table 6.1	N/A
6.2	Pulsed lamps		N/A
	Pulse lamp criteria shall apply to a single pulse and to any group of pulses within 0.25 s.	N/A – CW lamp.	N/A
	A pulsed lamp shall be evaluated at the highest nominal energy loading as specified by the manufacturer.		N/A
	The risk group determination of the lamp being tested shall be made as follows:		N/A
	– a lamp that exceeds the exposure limit shall be classified as belonging to Risk Group 3 (High-Risk)		N/A
	– for single pulsed lamps, a lamp whose weighted radiant exposure or weighted radiance does is below the EL shall be classified as belonging to the Exempt Group		N/A
	– for repetitively pulsed lamps, a lamp whose weighted radiant exposure or weighted radiance dose is below the EL, shall be evaluated using the continuous wave risk criteria discussed in clause 6.1, using time averaged values of the pulsed emission		N/A

IEC 62471			
Clause	Requirement + Test	Result – Remark	Verdict

Table 4.1	Spectral weighting function for assessing ultraviolet hazards for skin and eye			P
Wavelength ¹ λ , nm	UV hazard function $S_{uv}(\lambda)$	Wavelength λ , nm	UV hazard function $S_{uv}(\lambda)$	
200	0.030	313*	0.006	
205	0.051	315	0.003	
210	0.075	316	0.0024	
215	0.095	317	0.0020	
220	0.120	318	0.0016	
225	0.150	319	0.0012	
230	0.190	320	0.0010	
235	0.240	322	0.00067	
240	0.300	323	0.00054	
245	0.360	325	0.00050	
250	0.430	328	0.00044	
254*	0.500	330	0.00041	
255	0.520	333*	0.00037	
260	0.650	335	0.00034	
265	0.810	340	0.00028	
270	1.000	345	0.00024	
275	0.960	350	0.00020	
280*	0.880	355	0.00016	
285	0.770	360	0.00013	
290	0.640	365*	0.00011	
295	0.540	370	0.000093	
297*	0.460	375	0.000077	
300	0.300	380	0.000064	
303*	0.120	385	0.000053	
305	0.060	390	0.000044	
308	0.026	395	0.000036	
310	0.015	400	0.000030	

¹ Wavelengths chosen are representative: other values should be obtained by logarithmic interpolation at intermediate wavelengths.
* Emission lines of a mercury discharge spectrum.

IEC 62471			
Clause	Requirement + Test	Result – Remark	Verdict
Table 4.2	Spectral weighting functions for assessing retinal hazards from broadband optical sources		P
Wavelength nm	Blue-light hazard function B (λ)	Burn hazard function R (λ)	
300	0.01		
305	0.01		
310	0.01		
315	0.01		
320	0.01		
325	0.01		
330	0.01		
335	0.01		
340	0.01		
345	0.01		
350	0.01		
355	0.01		
360	0.01		
365	0.01		
370	0.01		
375	0.01		
380	0.01	0.1	
385	0.013	0.13	
390	0.025	0.25	
395	0.05	0.5	
400	0.10	1.0	
405	0.20	2.0	
410	0.40	4.0	
415	0.80	8.0	
420	0.90	9.0	
425	0.95	9.5	
430	0.98	9.8	
435	1.00	10.0	
440	1.00	10.0	
445	0.97	9.7	
450	0.94	9.4	
455	0.90	9.0	
460	0.80	8.0	
465	0.70	7.0	
470	0.62	6.2	
475	0.55	5.5	
480	0.45	4.5	
485	0.40	4.0	
490	0.22	2.2	
495	0.16	1.6	
500-600	$10^{[(450-\lambda)/50]}$	1.0	
600-700	0.001	1.0	
700-1050		$10^{[(700-\lambda)/500]}$	
1050-1150		0.2	
1150-1200		$0.2 \cdot 10^{0.02(1150-\lambda)}$	
1200-1400		0.02	

IEC 62471			
Clause	Requirement + Test	Result – Remark	Verdict

Table 5.4		Summary of the ELs for the surface of the skin or cornea (irradiance based values)				P
Hazard Name	Relevant equation	Wavelength range nm	Exposure duration sec	Limiting aperture rad (deg)	EL in terms of constant irradiance $W \cdot m^{-2}$	
Actinic UV skin & eye	$E_S = \sum E_\lambda \cdot S(\lambda) \cdot \Delta\lambda$	200 – 400	< 30000	1.4 (80)	30/t	
Eye UV-A	$E_{UVA} = \sum E_\lambda \cdot \Delta\lambda$	315 – 400	≤1000 >1000	1.4 (80)	10000/t 10	
Blue-light small source	$E_B = \sum E_\lambda \cdot B(\lambda) \cdot \Delta\lambda$	300 – 700	≤100 >100	< 0.011	100/t 1.0	
Eye IR	$E_{IR} = \sum E_\lambda \cdot \Delta\lambda$	780 – 3000	≤1000 >1000	1.4 (80)	18000/t ^{0.75} 100	
Skin thermal	$E_H = \sum E_\lambda \cdot \Delta\lambda$	380 – 3000	< 10	2π sr	20000/t ^{0.75}	

Table 5.5		Summary of the ELs for the retina (radiance based values)				P
Hazard Name	Relevant equation	Wavelength range nm	Exposure duration sec	Field of view radians	EL in terms of constant radiance $W \cdot m^{-2} \cdot sr^{-1}$	
Blue light	$L_B = \sum L_\lambda \cdot B(\lambda) \cdot \Delta\lambda$	300 – 700	0.25 – 10 10-100 100-10000 ≥ 10000	0.011·√(t/10) 0.011 0.0011·√t 0.1	10 ⁶ /t 10 ⁶ /t 10 ⁶ /t 100	
Retinal thermal	$L_R = \sum L_\lambda \cdot R(\lambda) \cdot \Delta\lambda$	380 – 1400	< 0.25 0.25 – 10	0.0017 0.011·√(t/10)	50000/(α·t ^{0.25}) 50000/(α·t ^{0.25})	
Retinal thermal (weak visual stimulus)	$L_{IR} = \sum L_\lambda \cdot R(\lambda) \cdot \Delta\lambda$	780 – 1400	> 10	0.011	6000/α	

IEC 62471			
Clause	Requirement + Test	Result – Remark	Verdict

Table 6.1 Emission limits for risk groups of continuous wave lamps									P
Risk	Action spectrum	Symbol	Units	Emission Measurement					
				Exempt		Low risk		Mod risk	
				Limit	Result	Limit	Result	Limit	Result
Actinic UV (*1)	S _{UV} (λ)	E _s	W•m ⁻²	0.001	N/A	0.003	N/A	0.03	N/A
Near UV (*1)		E _{UVA}	W•m ⁻²	10	N/A	33	N/A	100	N/A
Blue light (*1)	B(λ)	L _B	W•m ⁻² •sr ⁻¹	100	N/A	10000	N/A	4000000	N/A
Blue light, small source (*1)	B(λ)	E _B	W•m ⁻²	1.0*	N/A	1.0	N/A	400	N/A
Retinal thermal	R(λ)	L _R	W•m ⁻² •sr ⁻¹	28000/α = 3.76E+06	7.16E+04	28000/α	N/A	71000/α	N/A
Retinal thermal, weak visual stimulus** (*2)	R(λ)	L _{IR}	W•m ⁻² •sr ⁻¹	6000/α	N/A	6000/α	N/A	6000/α	N/A
IR radiation, eye		E _{IR}	W•m ⁻²	100	1.25E+01	570	N/A	3200	N/A

IEC 62471			
Clause	Requirement + Test	Result – Remark	Verdict

Table 6.1	Emission limits for risk groups of continuous wave lamps	P
<p>* Small source defined as one with $\alpha < 0.011$ radian. Averaging field of view at 10000 s is 0.1 radian. ** Involves evaluation of non-GLS source</p> <p>(*1): Not applicable since it is considered not to emit the outside of the following wavelength range: 700-1050nm. (*2): The emission was not considered weak visual stimulus. The measured luminance (averaged over 0.011 rad FOV) was 2.54E+01 cd•m⁻², which is more than 10 cd•m⁻².</p> <p>NOTE 1: The source is intended for non-general lighting service (non-GLS) use. Angular Subtense (α): 0.00745 rad (see Enclosure 1 for details.)</p> <p>NOTE 2: In addition to normal condition, some single faults to the LED driver circuit were simulated based on the applicant's request. Based on the result of single fault simulation, it was confirmed that neither IC908 5pin-6pin short resulted in higher output than the normal condition. Therefore, the result of normal condition was recorded as the worst condition.</p> <p>NOTE 3: Thermal hazard exposure limit for the skin (E_H). Total visible and infrared radiant exposure (380 nm to 3000 nm) of the skin E_H was determined as 1.25E+01 W•m⁻². For Maximum Exposure of 10 seconds, the EL was defined as 3.56E+03 W•m⁻²</p> <p>CONCLUSION: The radiation from the product was assigned as Exempt Group.</p>		

ENCLOSURE 1
ADDITIONAL INFORMATION ON TEST RESULTS
3 pages including this cover page

TEST CONDITION:

Testing was conducted on a test sample of model WV-S8574L with top cover removed as representative of all models. The IR LED of the test sample was operated at CW emission mode. Rating voltage was supplied from an external DC power supply (PoE+ Hub), provided by the applicant.

MEASUREMENT DISTANCE DETERMINATION:

Since the unit is intended for non-general lighting service (non-GLS), irradiance and radiance values were measured at the distance of 200mm from the source.

ANGULAR SUBTENSE:

To determine the angular subtense (α) of the sample, the apparent source was imaged by a lens into a beam profiler which measured the beam width. The ratio of the apparent source image size to the image distance (lens/profiler distance) was used to determine the angular subtense of the apparent source. See FIGURE 1 for two-dimensional profile images (beam topography).

Based on IEC62471 (2006) cl.4.2.2, the angular subtense (α) was determined by the arithmetic mean of two dimensions (α_v and α_h) of the source.

- $\alpha = 0.00745$ rad

TEST ENVIRONMENT:

Test Date:	2021-11-26
Room Ambient Temperature:	20 deg C
Room Humidity:	52 %Rh
Room Barometric Pressure:	1016 hPa

IMAGED BEAM PROFILE CHART

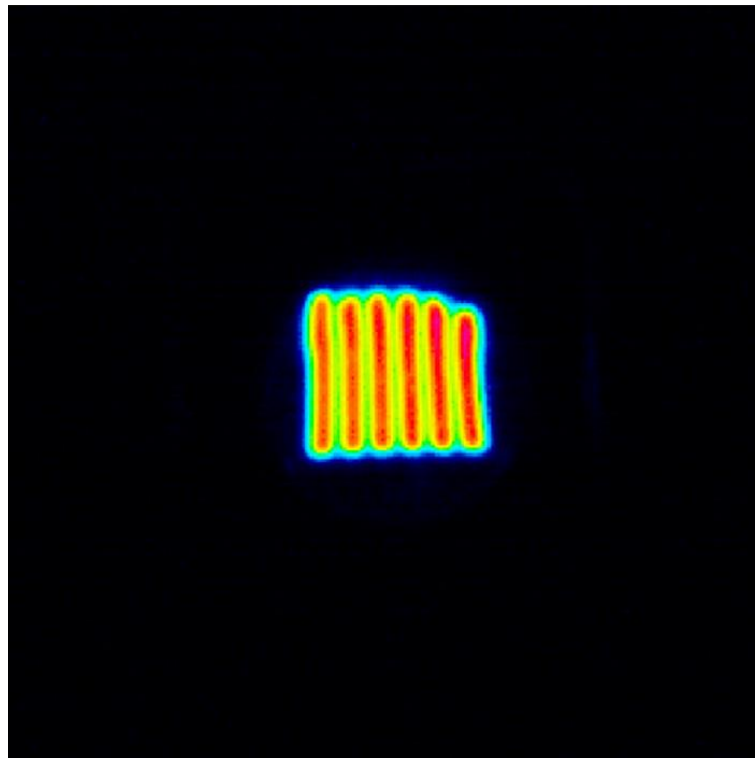

FIGURE 1: Imaged Beam Profile Chart

ABSOLUTE SPECTRAL DISTRIBUTION CHART

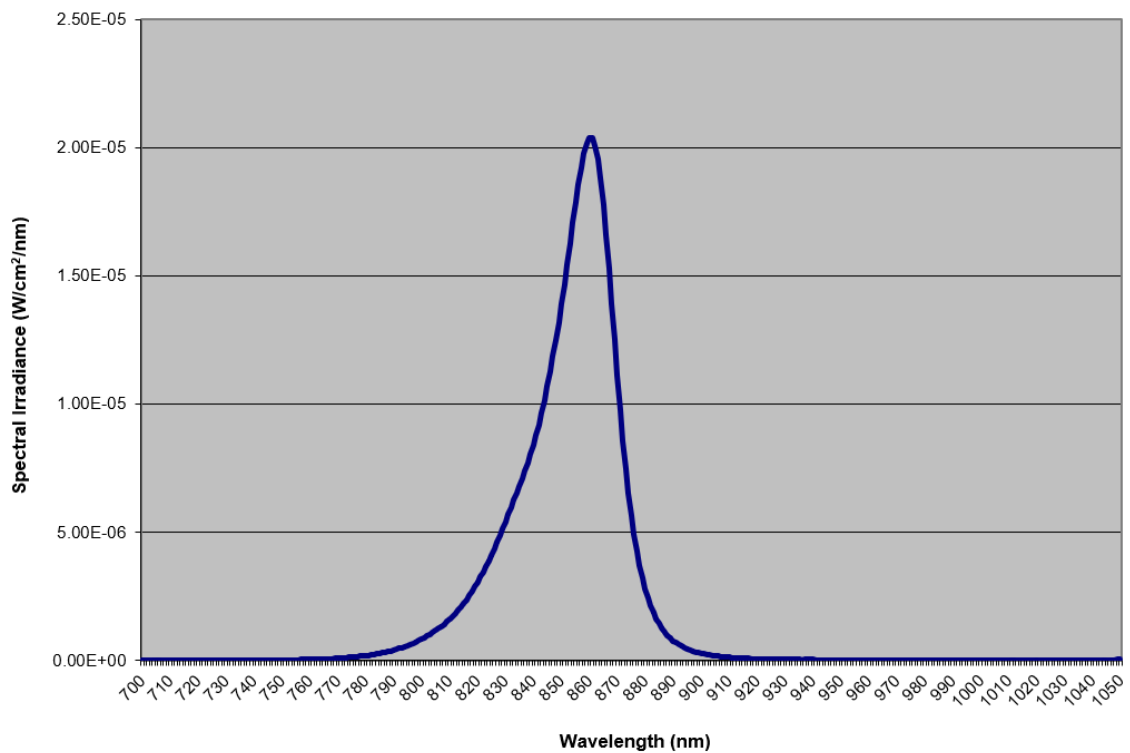

FIGURE 2: Absolute Spectral Distribution Chart

ENCLOSURE 2
PHOTOGRAPHS

2 pages including this cover page



FIGURE 3-a: Overall view 1 (Front, Top, Side)

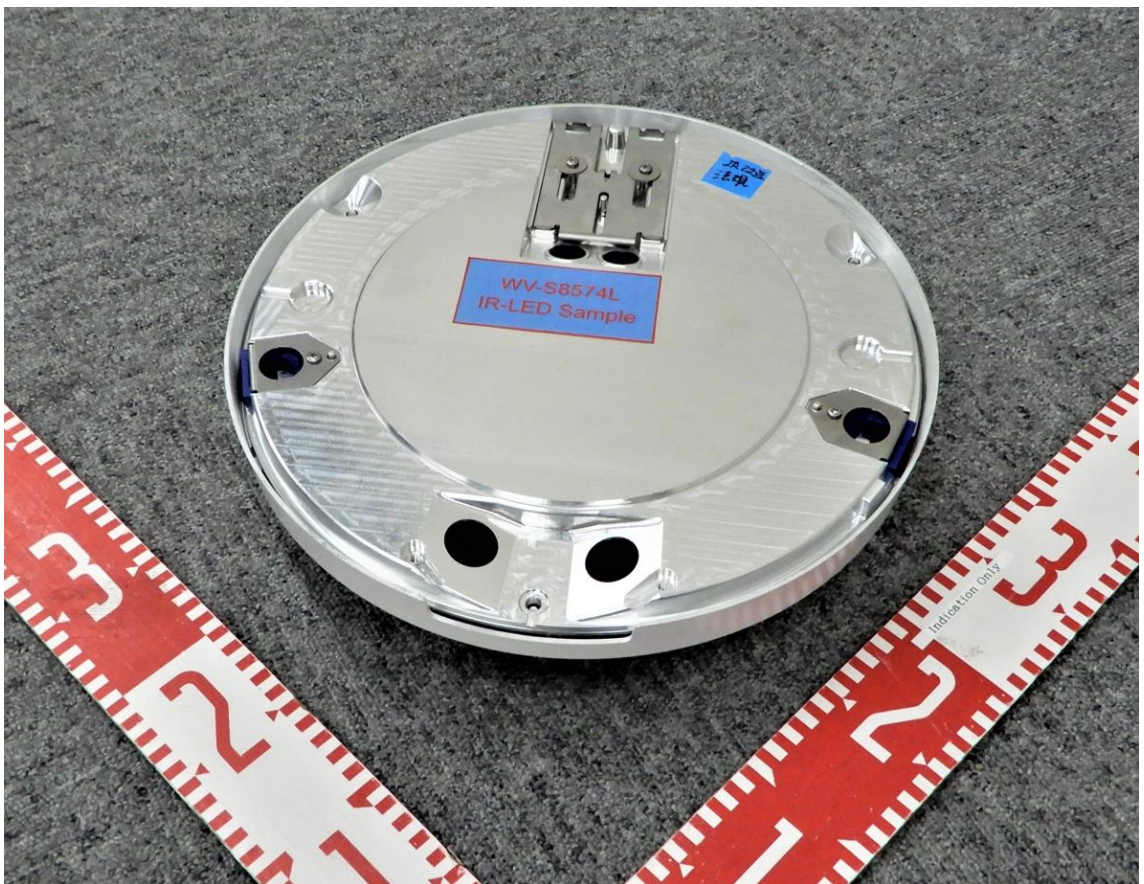
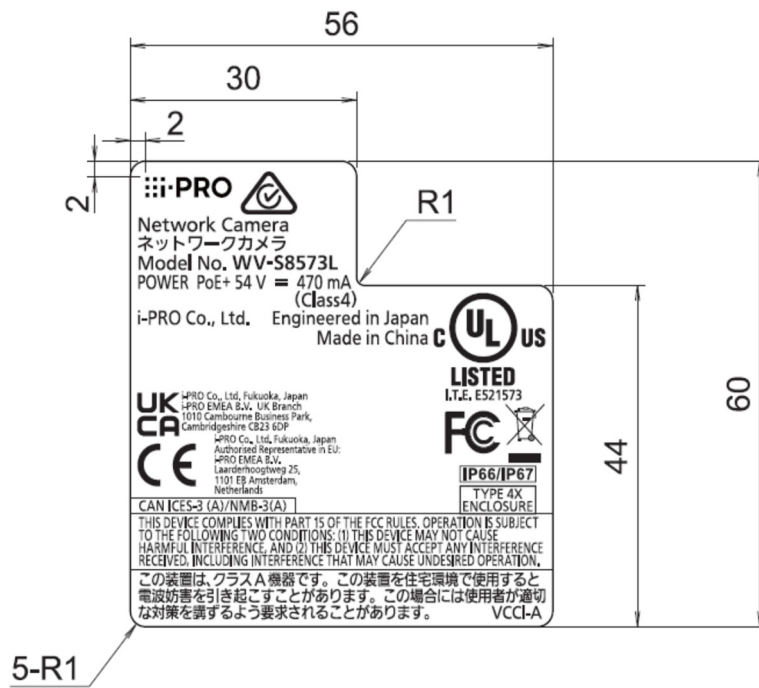
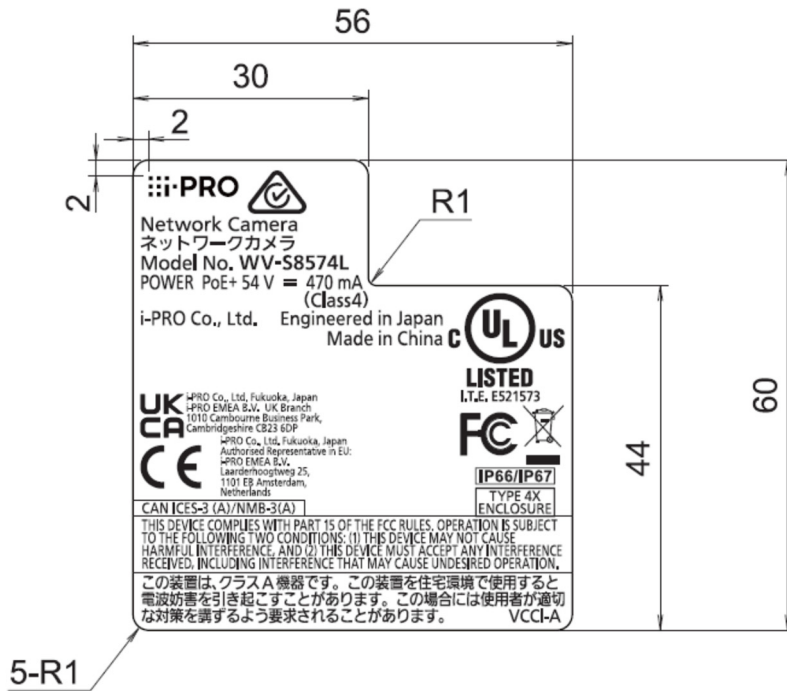
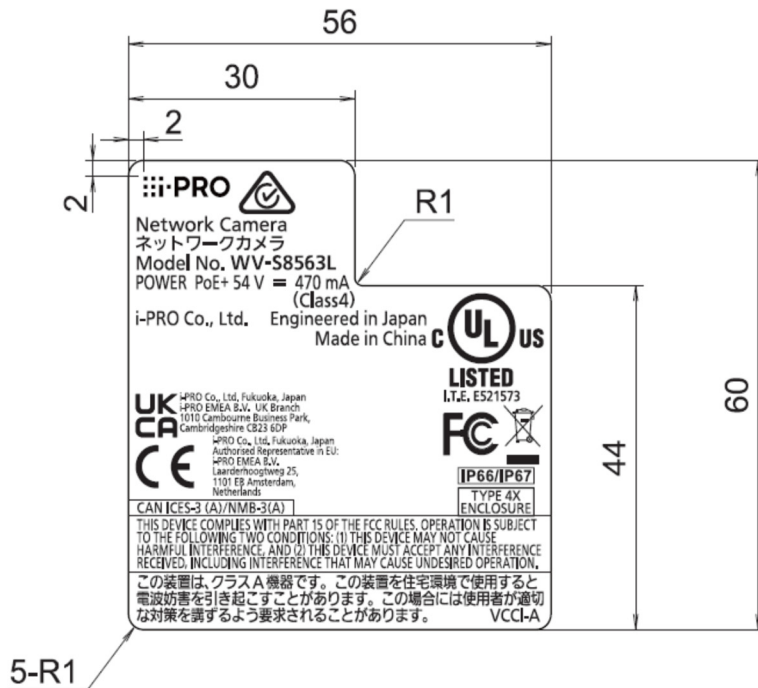
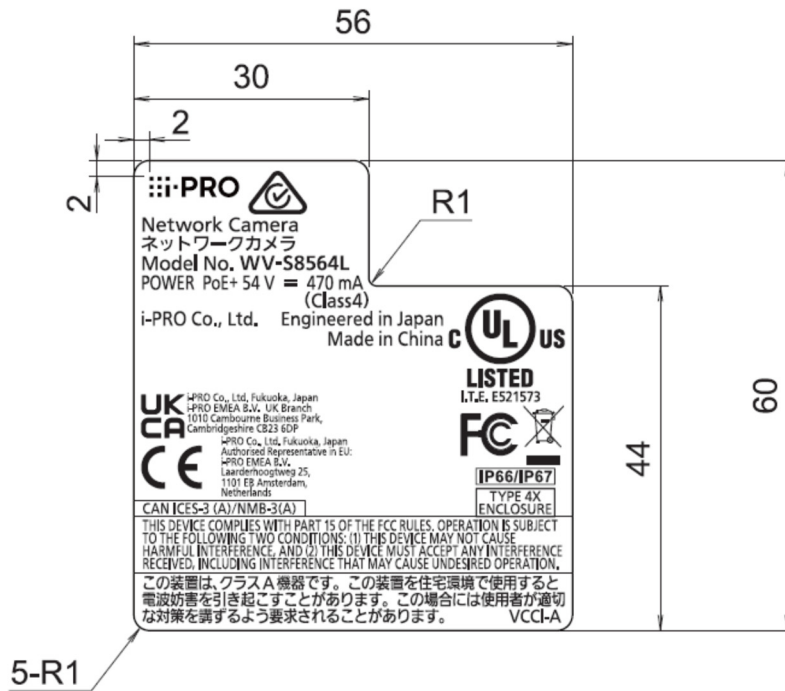

FIGURE 3-b: Overall view 2 (Rear, Bottom, Side)

ENCLOSURE 3
EUROPEAN GROUP DIFFERENCES AND NATIONAL DIFFERENCES
2 pages including this cover page

IEC62471B ATTACHMENT			
Clause	Requirement + Test	Result - Remark	Verdict
ATTACHMENT TO TEST REPORT IEC 62471 EUROPEAN GROUP DIFFERENCES AND NATIONAL DIFFERENCES Photobiological safety of lamps and lamps systems			
Differences according to: EN 62471:2008			
TRF template used : IECEE OD-2020-F2:2020, Ed. 1.1			
Attachment Form No.: EU_GD_IEC62471B			
Attachment Originator: OVE			
Master Attachment: Dated 2021-04-29			
Copyright © 2021 IEC System for Conformity Testing and Certification of Electrical Equipment (IECEE), Geneva, Switzerland. All rights reserved.			
	GENELEC COMMON MODIFICATIONS (EN)		P
4	EXPOSURE LIMITS		P
	Contents of the whole Clause 4 of IEC 62471:2006 moved into a new informative Annex ZB		—
	Clause 4 replaced by the following:		P
	The original Clause 4 of IEC 62471:2006 contains provisions governing limiting values for the exposure of persons falling within the area of the health and safety of workers. Within Europe those limiting values are already covered by the Artificial Optical Radiation Directive (2006/25/EC). Thus, the limits of the directive have to be applied instead of those fixed in IEC 62471:2006.		P
	There are no differences in EN 62471:2008 regarding the classification of lamps according Clause 6 of IEC 62471:2006.	See appended table 6.1	—
4.1	General		P
	Delete the first paragraph.		—





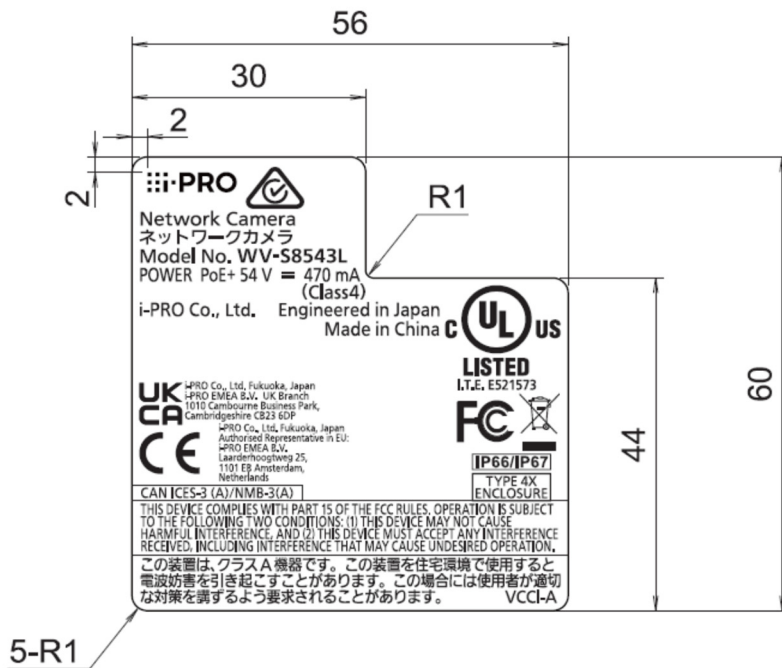
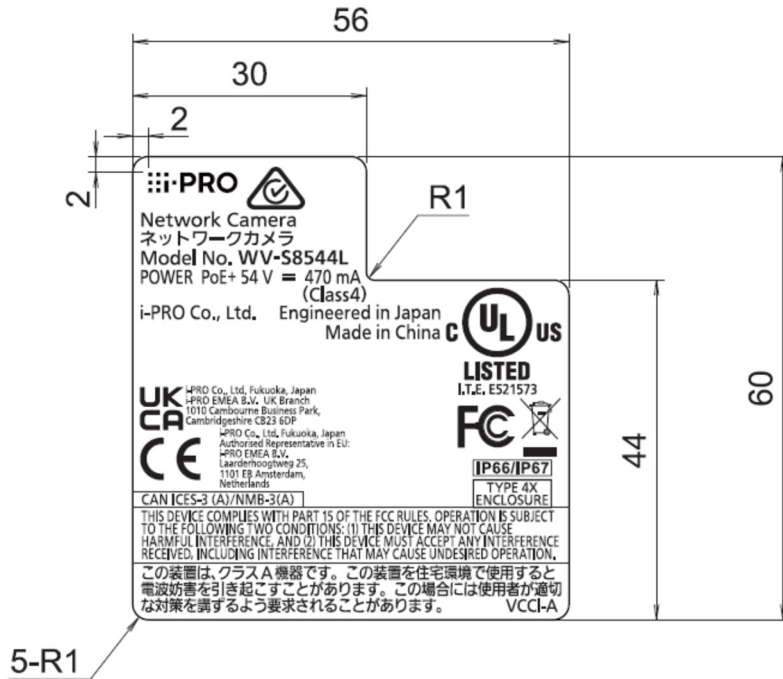

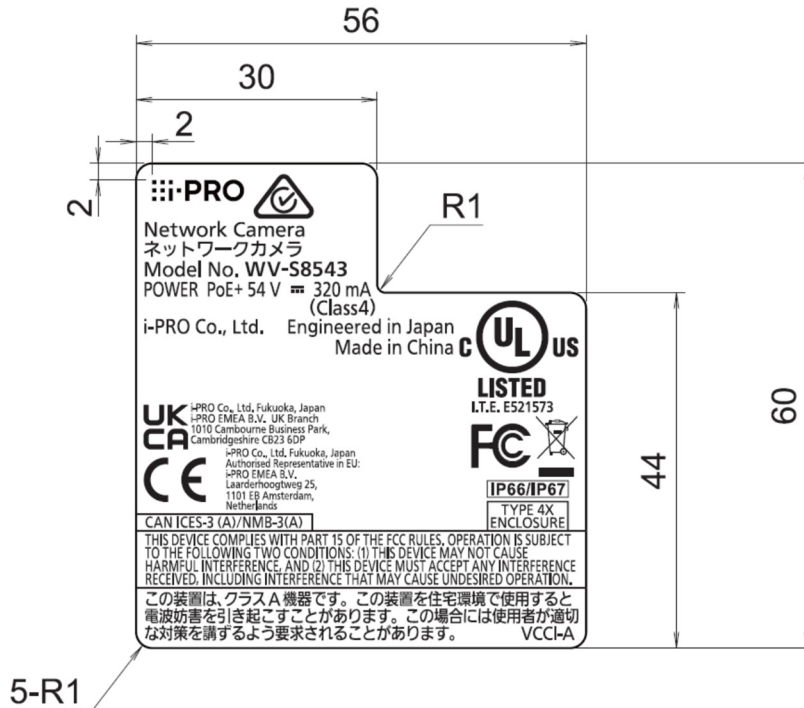
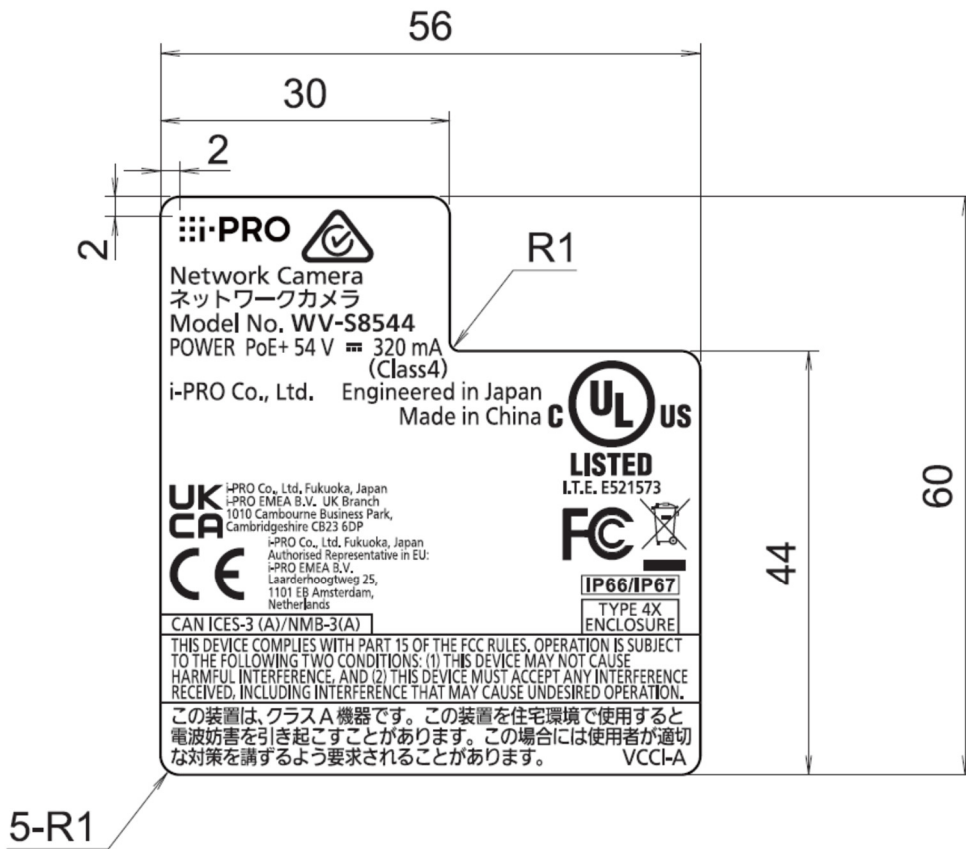

UL TEST REPORT AND PROCEDURE

Standard:	UL 62368-1, 3rd Ed, Issued: 2019-12-13 (Audio/video, information and communication technology equipment Part 1: Safety requirements) CAN/CSA C22.2 No. 62368-1:19, 3rd Ed, Issued: 2019-12-13 (Audio/video, information and communication technology equipment Part 1: Safety requirements)
Certification Type:	Listing
CCN:	AZOT, AZOT7 (Audio/video, Information and Communication Technology Equipment)
Complementary CCN:	N/A
Product:	Network Camera
Model:	1) WV-S8574L, WV-S8573L, WV-S8544L, WV-S8543L, WV-S8564L, WV-S8563L 2) WV-S8544, WV-S8543
Rating:	1) 54 V d.c.(PoE) 470 mA 2) 54 V d.c.(PoE) 320 mA
Applicant Name and Address:	Panasonic i-PRO Sensing Solutions Co., Ltd. 4-1-62 MINOSHIMA HAKATA-KU FUKUOKA-SHI FUKUOKA-KEN 812-8531 JAPAN

This is to certify that representative samples of the products covered by this Test Report have been investigated in accordance with the above referenced Standards. The products have been found to comply with the requirements covering the category and the products are judged to be eligible for Follow-Up Service under the indicated Test Procedure. The manufacturer is authorized to use the UL Mark on such products which comply with this Test Report and any other applicable requirements of UL LLC ('UL') in accordance with the Follow-Up Service Agreement. Only those products which properly bear the UL Mark are considered as being covered by UL's Follow-Up Service under the indicated Test Procedure.

The applicant is authorized to reproduce the referenced Test Report provided it is reproduced in its entirety.

UL authorizes the applicant to reproduce the latest pages of the referenced Test Report consisting of the first page of the Specific Technical Criteria through to the end of the Conditions of Acceptability.

Any information and documentation involving UL Mark services are provided on behalf of UL LLC (UL) or any authorized licensee of UL.

Prepared By: Kenshi Shimomura / Project
Handler

Reviewed By: Tadao Nakayama / Reviewer

Supporting Documentation

The following documents located at the beginning of this Procedure supplement the requirements of this Test Report:

A. Authorization - The Authorization page may include additional Factory Identification Code markings.

B. Generic Inspection Instructions -

- i. Part AC details important information which may be applicable to products covered by this Procedure. Products described in this Test Report must comply with any applicable items listed unless otherwise stated in the body of this Test Report.
- ii. Part AE details any requirements which may be applicable to all products covered by this Procedure. Products described in this Test Report must comply with any applicable items listed unless otherwise stated in the body of each Test Report.
- iii. Part AF details the requirements for the UL Certification Mark which is not controlled by the technical standard used to investigate these products. Products are permitted to bear only the Certification Mark(s) corresponding to the countries for which it is certified, as indicated in each Test Report.

Product Description

This product is a Network Camera for use in an outdoor environment.

This equipment is supplied from the External Power Supply.

External Power Supply : That External Power Supply itself is not evaluated in this report.

Model Differences

Refer to Enclosure Id: 07-01 for details of model differences.

WV-S8574L was used for test purposes and is considered representative of the entire series.

Test Item Particulars

Product group	end product
Classification of use by	Ordinary person Instructed person Skilled person
Supply Connection	not mains connected: ES1
Supply tolerance	None
Supply connection – type	External Power Supply
Considered current rating of protective device	N/A
Equipment mobility	stationary wall/ceiling-mounted
Over voltage category (OVC)	OVC II
Class of equipment	Class III
Special installation location	N/A
Pollution degree (PD)	PD 2
Manufacturer's specified T _{ma} (°C)	60
IP protection class	IP 66 / 67
Power systems	not AC mains
Altitude during operation (m)	2000 m or less
Altitude of test laboratory (m)	1000 m
Mass of equipment (kg)	3.3kg (Mode WV-S8574L, WV-S8544L, WV-S8564L, WV-S8544), 3.1kg (Model WV-S8573L, WV-S8543L, WV-S8563L, WV-S8543)

Additional Information

Maximum normal load is continuous recording and LED lighting.

Additional Standards

The product fulfills the requirements of: UL 62368-1 3rd Edition, Issued December 13, 2019, CAN/CSA C22.2 No. 62368-1:19, 3rd Edition

Markings and Instructions

Clause Title	Marking or Instruction Details
Equipment identification marking – Manufacturer identification	Listee's or Recognized Company's name, Trade Name, Trademark or File Number
Equipment identification marking – model identification	Model Number
Equipment rating marking – ratings	Input Ratings (voltage, frequency/dc, current/power)

Special Instructions to UL Representative

N/A

BD1.0						
TABLE: Production-Line Testing Requirements						
BD1.1						
Electric Strength Test Special Constructions – Refer to Generic Inspection Instructions, Part AC for further information.						
Model	Component	Removable parts	Test probe location	Test V rms	Test V dc	Test Time, s
--	--	--	--	--	--	--
BD1.2						
Earthing Continuity Test Exemptions – This test is not required for the following models:						
All models						
BD1.3						
Electric Strength Test Exemptions – This test is not required for the following models:						
All models						
BD1.4						
Electric Strength Test Component Exemptions – The following solid-state components may be disconnected from the remainder of the circuitry during the performance of this test.						
N/A						

BE1.0					
Sample and Test Specifics for Follow-Up Tests at UL					
Model	Component	Material	Test	Sample (s)	Test Specifics
--	--	--	--	--	--

4.1.2	TABLE: List of critical components					Pass
Object / part No.	Manufacturer/ trademark	Type / model	Technical data	Product Category CCN(s)	Mark(s) of conformity	Supplement ID
PoE Input Connector (JK901)	Dongguan Yuqiu Electronics Co., Ltd.	RJ011-FD08S3B1G10	AC150V, 0.5A	--	(Tested in equipment)	
Lithium Battery (B301)	Panasonic Corp.	BR-1225 or BR-1225A	3.0V, 48mAh, Maximum Abnormal Charging Current: 3.0mA	BBCV2	UL	
Alternative	POWER GLORY BATTERY TECH (HK) CO., LTD.	BR1225	3.0V, 48mAh, Maximum Abnormal Charging Current: 10mA	BBCV2	UL	
IR LED (D1301) for WV-S8574L, WV-S8573L, WV-S8564L, WV-S8563L, WV-S8544L, WV-S8543L [6 pcs.]	OSRAM OPTO SEMICONDUCTOR S GMBH	SFH4715AS	1500mA, 5.8W	--	(Tested in equipment)	
Lens Module for WV-S8544L, WV-S8544 [4 pcs.], WV-S8543L, WV-S8543 [3 pcs.]	Tamron Co., Ltd.	DF036L0010	Constructed with Focus motor, Zoom motor, D/N IR motor and Thermistor.	--	(Tested in equipment)	
Lens Module for WV-S8574L, WV-S8564L [4 pcs.], WV-S8573L, WV-S8563L [3 pcs.]	Konica Minolta, Inc.	ADVJ008	No motor included.	--	(Tested in equipment)	
D/N motor for WV-S8574L, WV-S8564L [4 pcs.], WV-S8573L, WV-S8563L [3 pcs.]	ShaanXi XuanYi Optic & Electronic CO., Ltd.	S113-P4	3.3V-7VDC, 25ohms	--	(Tested in equipment)	

PCBs	Interchangeable	Interchangeable	Minimum V-1, Minimum 130°C	ZPMV2	UL	
Flexible PCBs	Interchangeable	Interchangeable	Minimum V-1, Minimum 80°C	ZPK2	UL	
Internal Wires	Interchangeable	Interchangeable	VW-1, Minimum 30V, Minimum 80°C	AVLV2	UL	
DOME LENS MULTI C	Mitsubishi Engineering - Plastic Corp.	S-2000VUR(f1)	Minimum 0.38mm thick, V-2	QMFZ2	UL	
Alternative	Interchangeable	Interchangeable	Minimum HB at thickness and color used.(Suitable for outdoor use with respect to exposure to Ultraviolet Light, Water Exposure and Immersion in accordance with UL 746C.)	QMFZ2	UL	
IR-LED COVER C for WV-S8574L, WV-S8573L, WV-S8564L, WV-S8563L, WV-S8544L, WV-S8543L	Mitsubishi Engineering - Plastic Corp.	S-2000UR(f1)	Minimum 0.38mm thick, V-2	QMFZ2	UL	
Alternative	Interchangeable	Interchangeable	Minimum HB at thickness and color used.(Suitable for outdoor use with respect to exposure to Ultraviolet Light, Water Exposure and Immersion in accordance with UL 746C.)	QMFZ2	UL	

IR-LED COVER W for WV-S8544, WV-S8543	Mitsubishi Engineering - Plastic Corp.	LN-3520ZH(f1)	Minimum 1.0mm thick, V-2	QMFZ2	UL	
Alternative	Interchangeable	Interchangeable	Minimum HB at thickness and color used.(Suitable for outdoor use with respect to exposure to Ultraviolet Light, Water Exposure and Immersion in accordance with UL 746C.)	QMFZ2	UL	
LENS COVER UPPER	Teijin Chemicals Plastic Compounds Shanghai Ltd.	LN-1250G	Minimum 1.0mm thick, V-0	QMFZ2	UL	
Alternative	Interchangeable	Interchangeable	Minimum HB at thickness used.	QMFZ2	UL	
LENS COVER LOWER	Teijin Chemicals Plastic Compounds Shanghai Ltd.	LN-1250G	Minimum 1.0mm thick, V-0	QMFZ2	UL	
Alternative	Interchangeable	Interchangeable	Minimum HB at thickness used.	QMFZ2	UL	
PAN BASE	Teijin Chemicals Plastic Compounds Shanghai Ltd.	LN-1250G	Minimum 1.0mm thick, V-0	QMFZ2	UL	
Alternative	Interchangeable	Interchangeable	Minimum HB at thickness used.	QMFZ2	UL	
PAN CHASSIS STOPPER	Teijin Chemicals Plastic Compounds Shanghai Ltd.	LN-1250G	Minimum 1.0mm thick, V-0	QMFZ2	UL	
Alternative	Interchangeable	Interchangeable	Minimum HB at thickness used.	QMFZ2	UL	
SD COVER	Teijin Chemicals Plastic Compounds Shanghai Ltd.	LN-1250G	Minimum 1.0mm thick, V-0	QMFZ2	UL	

Alternative	Interchangeable	Interchangeable	Minimum HB at thickness used.	QMFZ2	UL	
LAN COVER	Teijin Chemicals Plastic Compounds Shanghai Ltd.	LN-1250G	Minimum 1.0mm thick, V-0	QMFZ2	UL	
Alternative	Interchangeable	Interchangeable	Minimum HB at thickness used.	QMFZ2	UL	
PAN CHASSIS BASE	Teijin Chemicals Plastic Compounds Shanghai Ltd.	LN-1250G	Minimum 1.0mm thick, V-0	QMFZ2	UL	
Alternative	Interchangeable	Interchangeable	Minimum HB at thickness used.	QMFZ2	UL	
MULTI BASE SHEET	Shenzhen Teesun Technology Co., Ltd.	TS-FR1370	Minimum 0.25mm thick, V-0	QMFZ2	UL	
Alternative	Interchangeable	Interchangeable	Minimum V-0 at thickness used.	QMFZ2	UL	
FRAME BASE HOUSING	Interchangeable	ADC12	Aluminum	--	(Tested in equipment)	
MULTI BASE	Interchangeable	AlSi10Mg	Aluminum alloy	--	(Tested in equipment)	
DOME PACKING	Dow Corning Toray Silicone Co., Ltd.	RBB-6650-50	Silicone, Black	QMFZ2	UL	
Alternative	JIANGSU PEARL SILICONE RUBBER MATERIAL CO., LTD.	HD-87XX (Hardness: 40)	Silicone, Black	QMFZ2	UL	
Alternative	JIANGSU PEARL SILICONE RUBBER MATERIAL CO., LTD.	HD-87XX (Hardness: 50)	Silicone, Black	QMFZ2	UL	
Alternative	JIANGSU PEARL SILICONE RUBBER MATERIAL CO., LTD.	HD-87XX (Hardness: 60)	Silicone, Black	QMFZ2	UL	

GROMMET	Dow Corning Toray Silicone Co., Ltd.	RBB-6630-30	Silicone, Black	QMFZ2	UL	
Alternative	WYNCA TINYO SILICONE CO., LTD.	TY856(Hardness: 30)	Silicone, Natural	QMFZ2	UL	

Enclosures

Type	Supplement Id	Description
Photographs	03-01	Overall view_1
Photographs	03-02	Overall view_2
Photographs	03-03	Overall view_3
Photographs	03-04	Overall view_4
Photographs	03-05	Internal view
Photographs	03-06	PWB_1
Photographs	03-07	PWB_2
Schematics + PWB	05-01	Schematics for RTC and Temp Sensor circuits
Miscellaneous	07-01	Model Differences
Miscellaneous	07-02	IEC 62471 Test Report for AF LED
Miscellaneous	07-03	Marking Label

Model difference

Model	Pixel count	Number of Lenses	Zoom lens	IR-LED	Rating	Remarks
WV-S8574L	4K	4	No	Yes	PoE+ 54Vdc, 470mA	Basic model: Max power consumption
WV-S8573L	4K	3	No	Yes	PoE+ 54Vdc, 470mA	
WV-S8544L	4M	4	Yes	Yes	PoE+ 54Vdc, 470mA	
WV-S8543L	4M	3	Yes	Yes	PoE+ 54Vdc, 470mA	
WV-S8544	4M	4	Yes	No	PoE+ 54Vdc, 320mA	
WV-S8543	4M	3	Yes	No	PoE+ 54Vdc, 320mA	
WV-S8564L	6M	4	No	Yes	PoE+ 54Vdc, 470mA	
WV-S8563L	6M	3	No	Yes	PoE+ 54Vdc, 470mA	

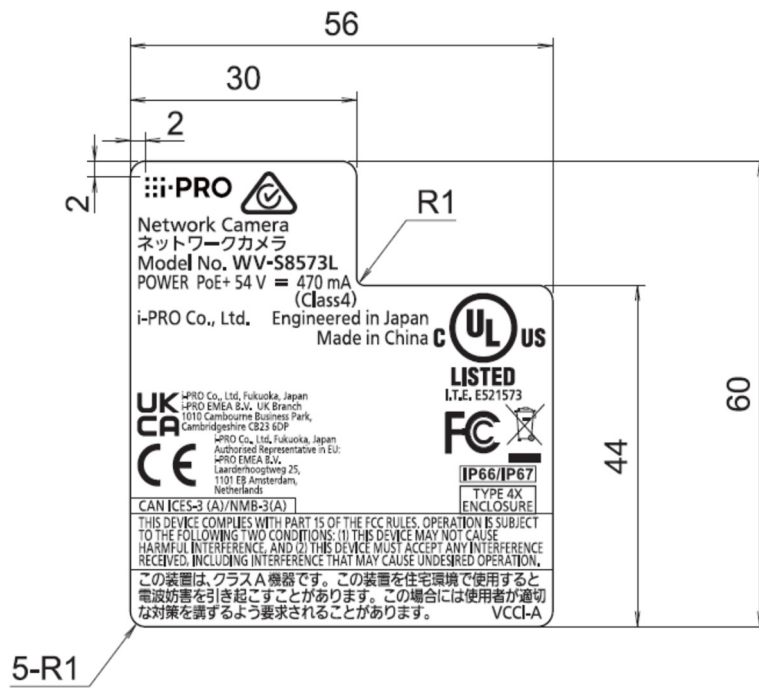
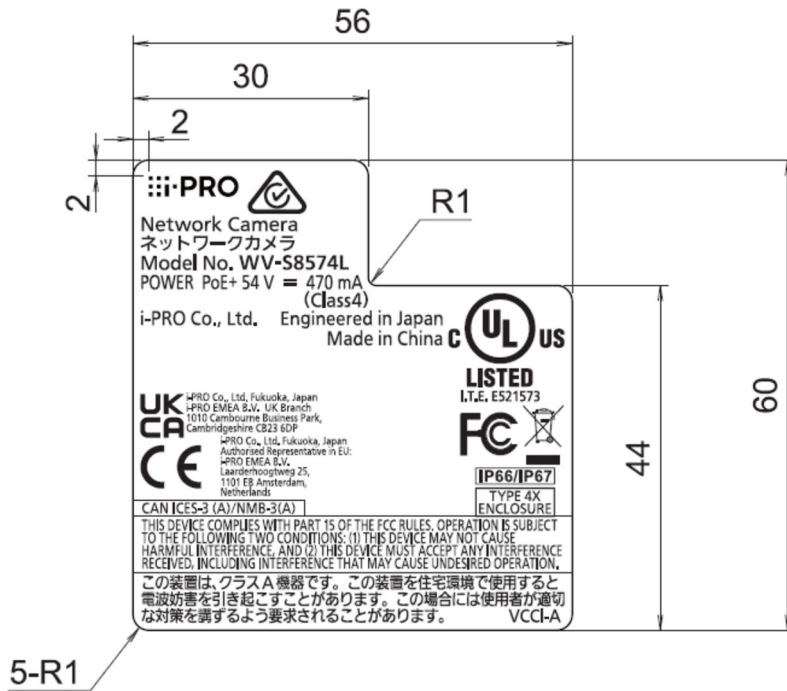

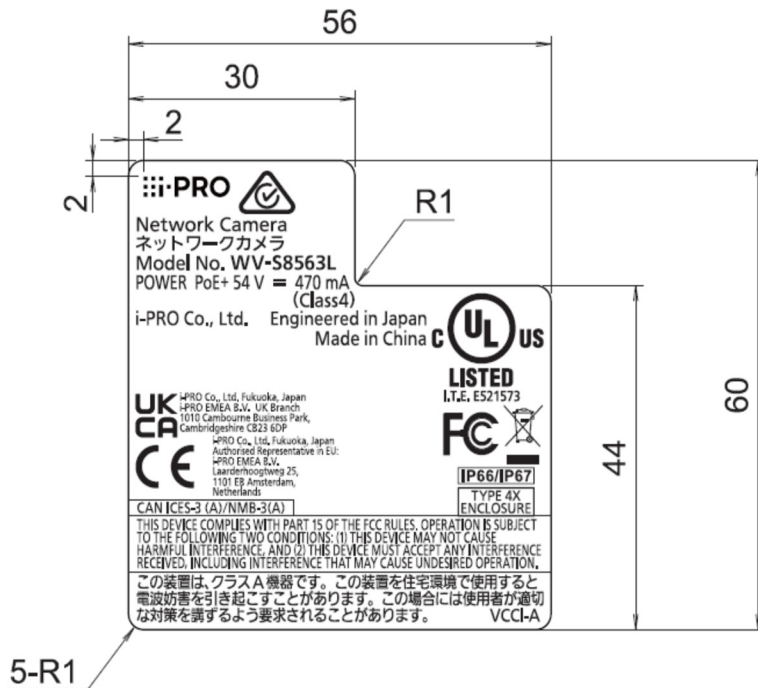
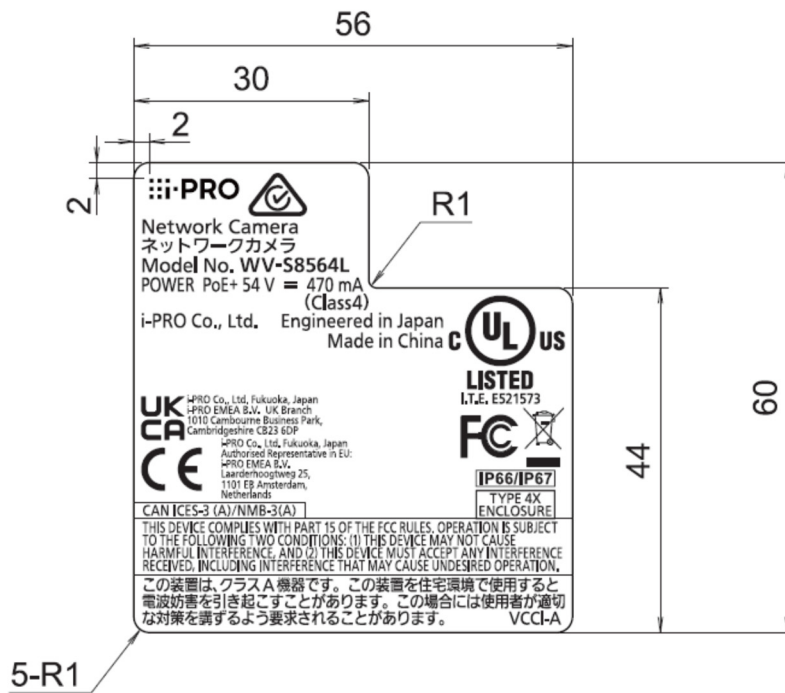

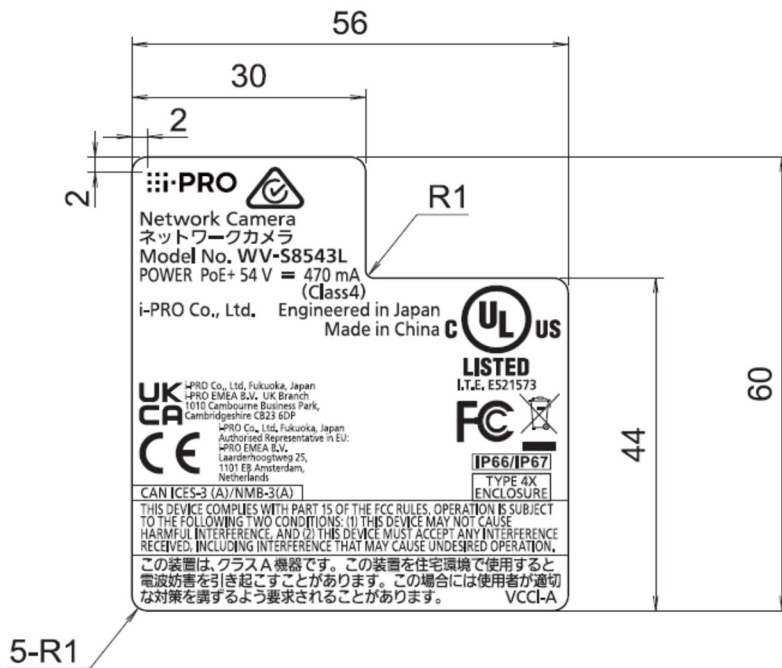
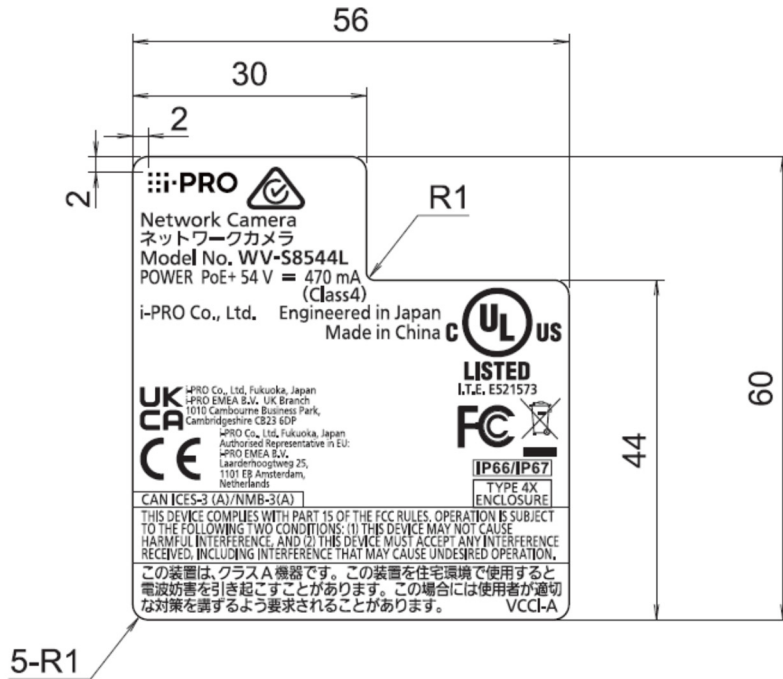

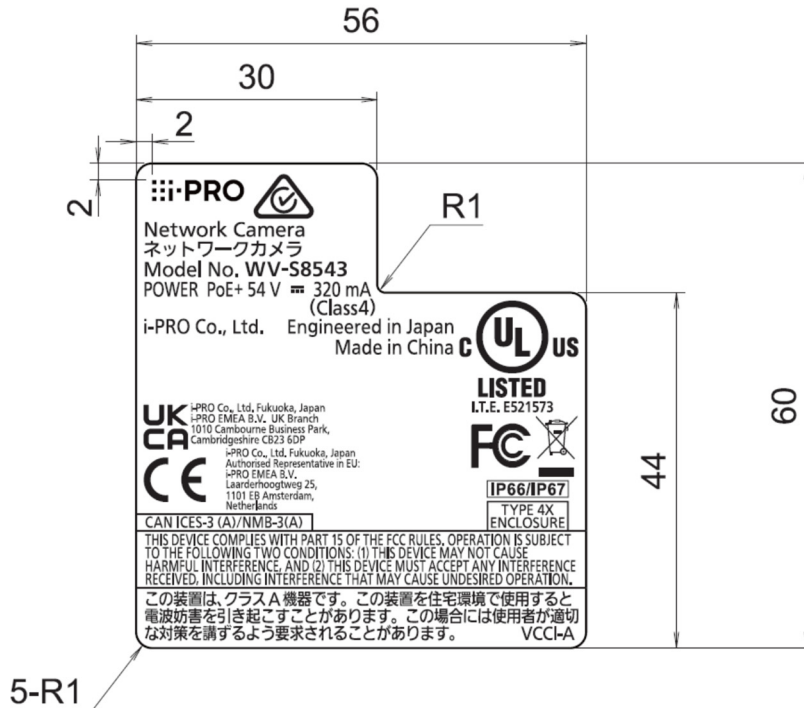
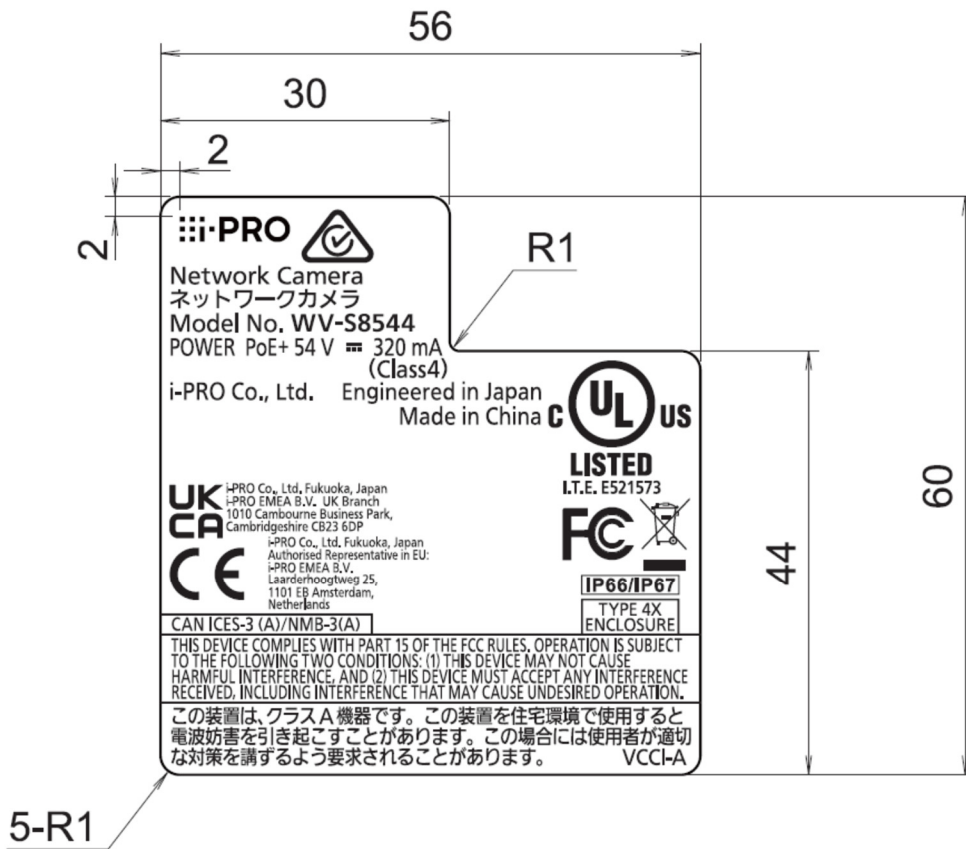



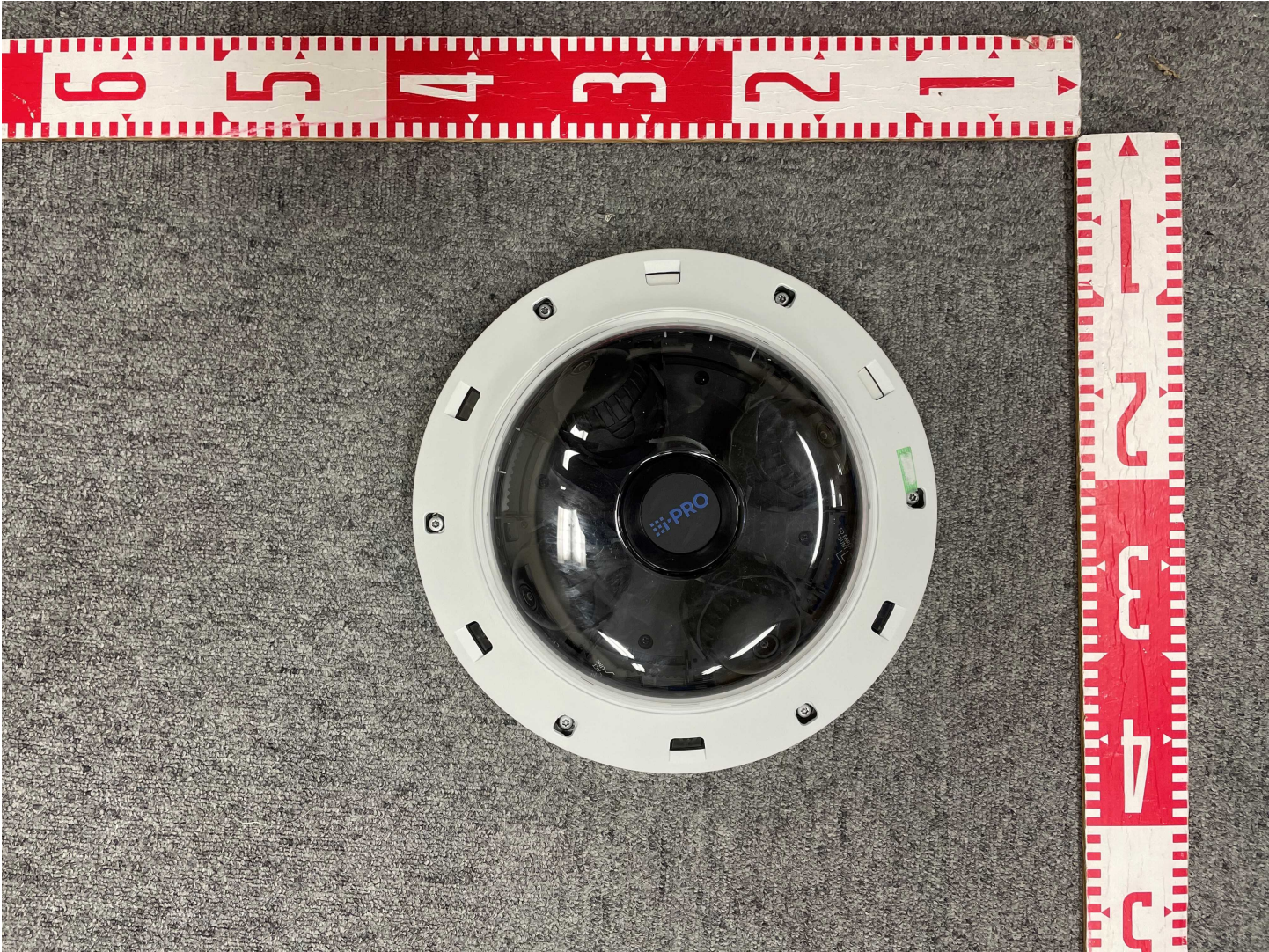





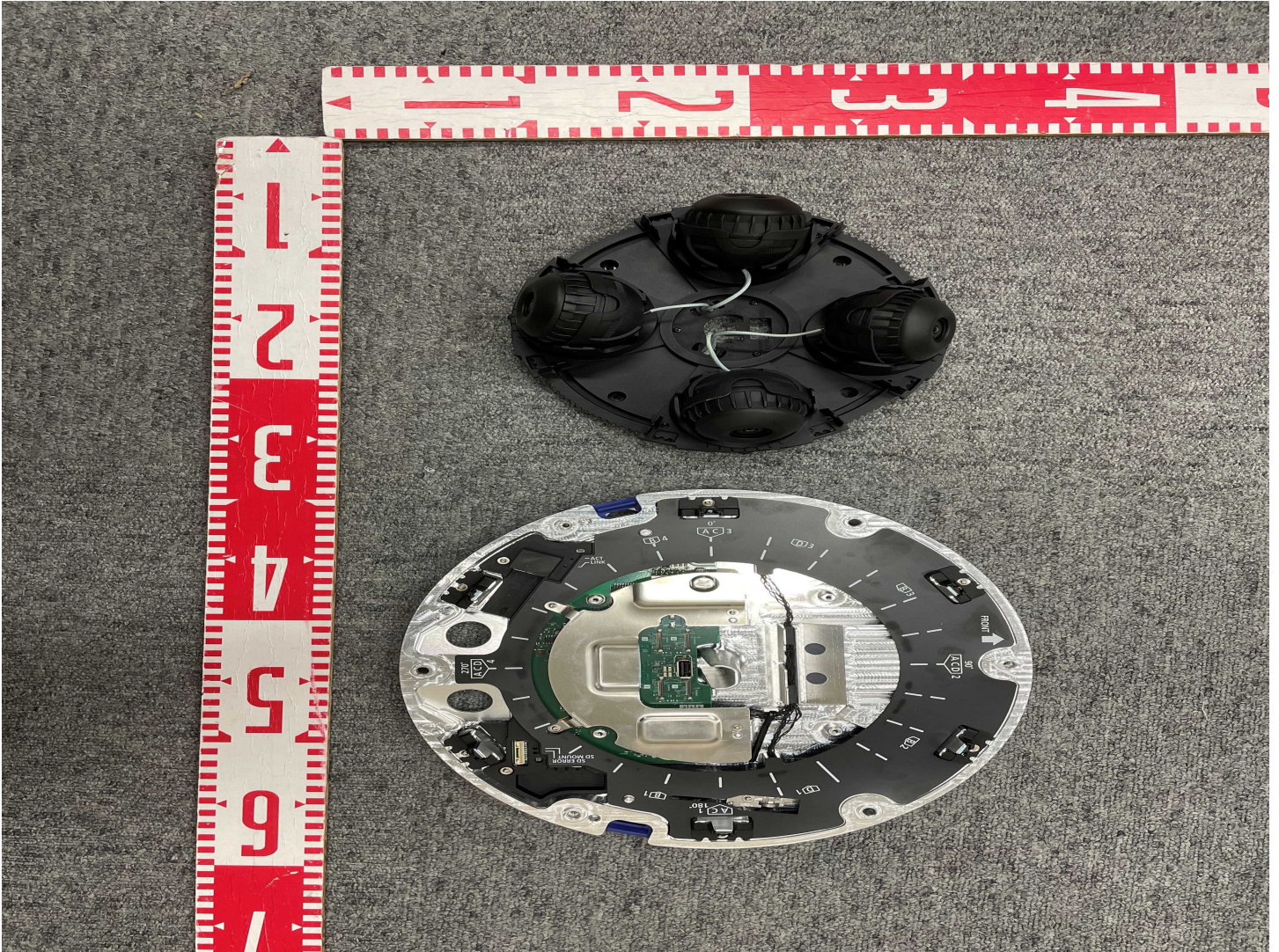



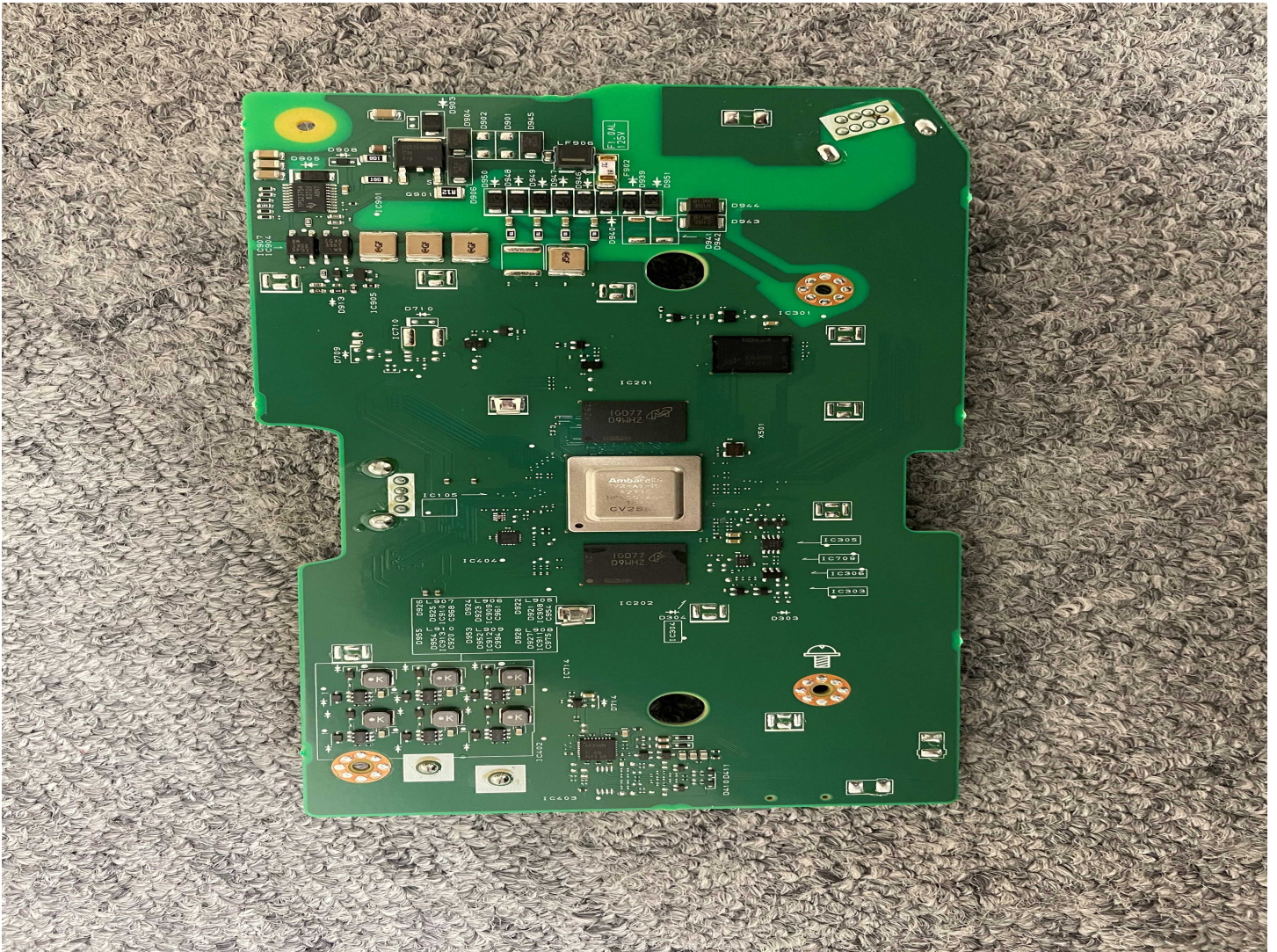

【RTC & Temp Sensor】

