

i-PRD
SmartHD

i-PRD
SmartHD



Vandal Resistant Network Camera

WV-SW355/352

Security & AV Systems Business Unit
Panasonic System Networks Company

Panasonic ideas for life

WV-SW355/SW352 Overview

Outdoor Vandal



2011.03
Target

ONVIF

WV-SW355

HD/ 720P, 30fps

TRUE D/N

Lens AF

Face Detection



2011.03
Target

WV-SW352

800x600, 30fps

TRUE D/N

Lens AF

Face Detection

- ❑ Vandal resistant (IEC60068-2-75) / IP66 water and dust proof
- ❑ Progressive output with Mega Super Dynamic(SW355)/ Super Dynamic(SW352)
- ❑ Extra Optical Zoom / VIQS (Variable Image Quality on Specified area)
- ❑ SD recording
- ❑ New 1.3M RGB MOS sensor with High Dynamic Range
- ❑ Real time HD/720P video with H.264 High Profile format(SW355)
- ❑ High sensitivity: 0.3 lux(SW355) / 0.2lux(SW352) @ color mode

Panasonic ideas for life

WV-SW355 series Key Features

i-PRO
SmartHD

Vandal Resistance Camera Product Concept

- HD 720p (1280x960) 30fps H.264 Encode **SW355**
- SVGA (800x600) 30fps H.264 Encode **SW352**

H.264(MPEG-4) x2 & JPEG Triple Encode
<Max bit rate 16Mbps>

Vandal resistant
IEC60068-2-75 test Eh, 50J/IEC 62262 IK10

IP66 -30 °C ~ 50 °C
(with Option Heater (WV-SW3H))



Mega Super Dynamic with face detection **SW355**
Super Dynamic with face detection **SW352**

New! **VIQS**(Variable Image Quality on Specified area)

New! **Extra Optical Zoom x2(Under VGA)**

SDHC/SD memory card (H.264 recording)

One Panasonic software
Onvif / HTTPS / DDNS / Cellular Phone

New! **Lens Auto Focus with Day/Night function**
※Built-In type Lens

i-PRO
ONVIF



BB Technology

Mega Super Dynamic sensor
NEW 1.3M RGB MOS sensor
with High Dynamic Range



UniPhier



UniPhier

■ 4:3 aspect ratio

- H.264 : 1280×960 max 30 fps **SW355**
800 × 600 max 30 fps **SW352**
- MPEG-4: VGA(640×480) max 30 fps **SW355**
- JPEG : 1280×960 max 30 fps **SW355**
800 × 600 max 30 fps **SW352**

■ 16:9 aspect ratio

- H.264: **720p** max 30 fps **SW355**
640 x 360 max 30 fps **SW352**
- JPEG : **720p** max 30 fps **SW355**
640 x 360 max 30 fps **SW352**

Panasonic ideas for life★

Vandal Resistant ability

Panasonic defines the vandal resistant as camera of more than IK10(IEC62262).

We verified the IEC 62262(IK10) and IEC 60068-2-75 test Eh, 50J of impact resistant test.
As a result, we could confirm a vandal resistant ability under both impact test as follows.



IEC 62262
IK10

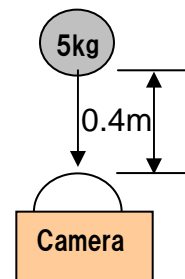

0.4m X 5 times by free fall

IEC 60068-
2-75 test Eh
50J

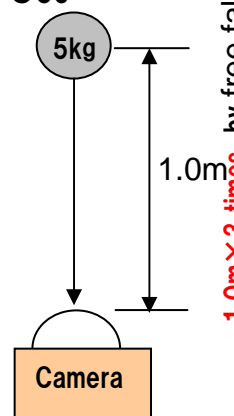

1.0m X 3 times by free fall

Weight (5kg)
The top figure:
SR50



Instrument for
Impact test



IEC 62262*	IK01	IK02	IK03	IK04	IK05	IK06	IK07	IK08	IK09	IK10	
Impact energy (J)	0.14J	0.2J	0.35J	0.5J	0.7J	1J	2J	5J	10J	20J	
Free fall (times)	5	5	5	5	5	5	5	5	5	5	
IEC 60068-2-75**	0.14J	0.2J	0.35J	0.5J	0.7J	1J	2J	5J	10J	20J	50J
Free fall (times)	3	3	3	3	3	3	3	3	3	3	3

*IEC 62262 (=originally defined in European Standard BS EN 50102:1995)

Degrees of protection provided by enclosures for electrical equipment against external mechanical impacts (IK code)

**IEC 60068-2-75:1997 (=JIS C 60068-2-75:2004)

Environmental testing - Part 2-75: Tests - Test Eh: Hammer tests

Vandal Resistant Structure

■ Structure is changed from NW502 but ability is same (explain next page)

<SW355, SW352>

<NW502>

Shock-avoidance structure

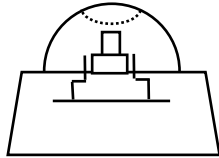

Clearance between Dome and Lens is enough. So shock-absorber isn't necessary.

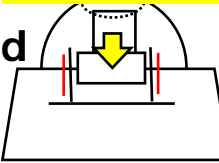

Equip shock-absorbing function

Between Dome and Lens is so close. So shock-absorber is necessary.

Using built-in Lens, camera part will be very compact.

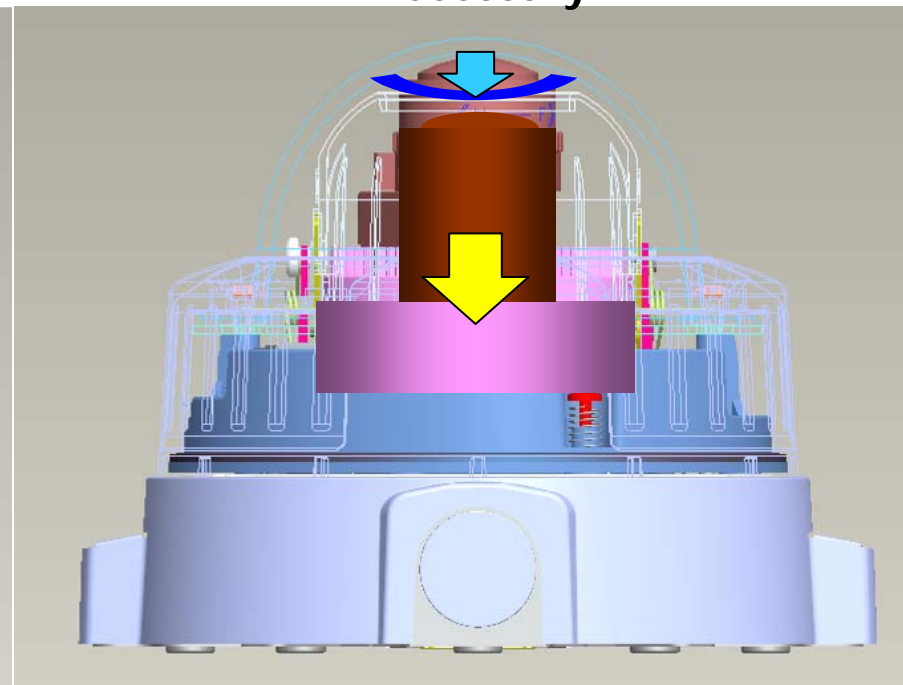
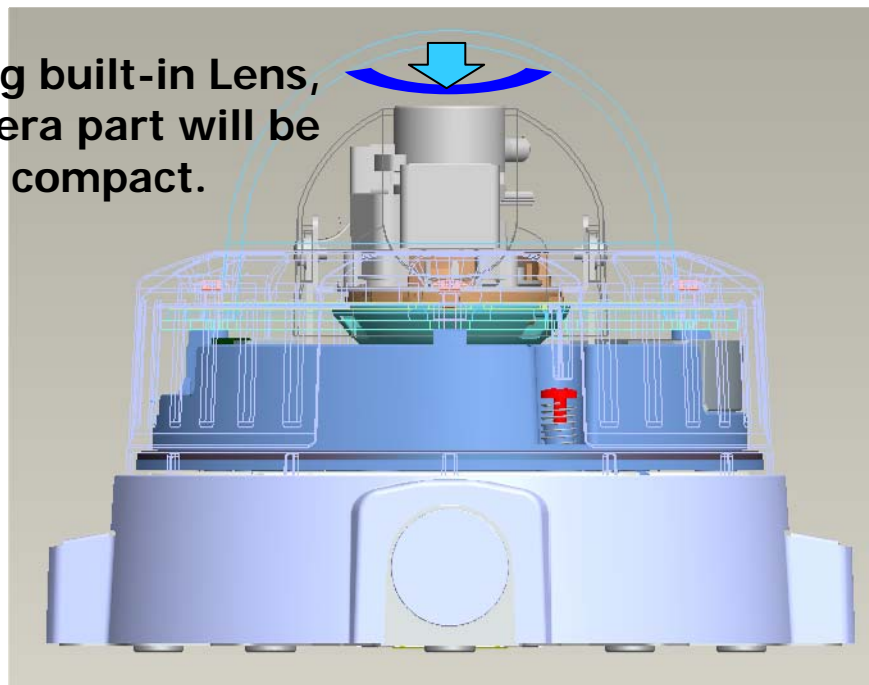

Performance Difference

i-PRO
SmartHD

Item	WV-SW355	WV-SW352	WV-NW502S	WV-NW484S
Minimum illumination	0.3 lx	0.2 lx	1.0 lx	0.6 lx
SD	Mega Super Dynamic (30fps)	Super Dynamic (30fps)	Mega Super Dynamic (15fps)	SD3
Max Resolution	1280x960	800x600	2048x1536	640X480
Lens mount	Built-In	Built-In	CS-mount	CS-mount
ABF	Lens AF	Lens AF	ABF	ABF
Zoom	3.6x optical 2.0x extra optical 4.0x electric	3.6x optical 2.0x extra optical 4.0x electric	2.8x optical 4.0x electric	2.0x optical 4.0x electric
Upside-down	×	×	○	○
Privacy Zone	2 (Gray only)	2 (Gray only)	8 (Gray/Mosaic)	8 (Gray/Mosaic)
VIQS	○	○	○(Future)	Non
i-PRO+BB Software	○	○	○(Future)	Non
Onvif	Ver1.01	Ver1.01	○(Future)	Non

Panasonic ideas for life

SD (Mega Super Dynamic) performance *i-PRG* SmartHD

Using new MOS sensor, SW355/352 can provide the Super Dynamic function.

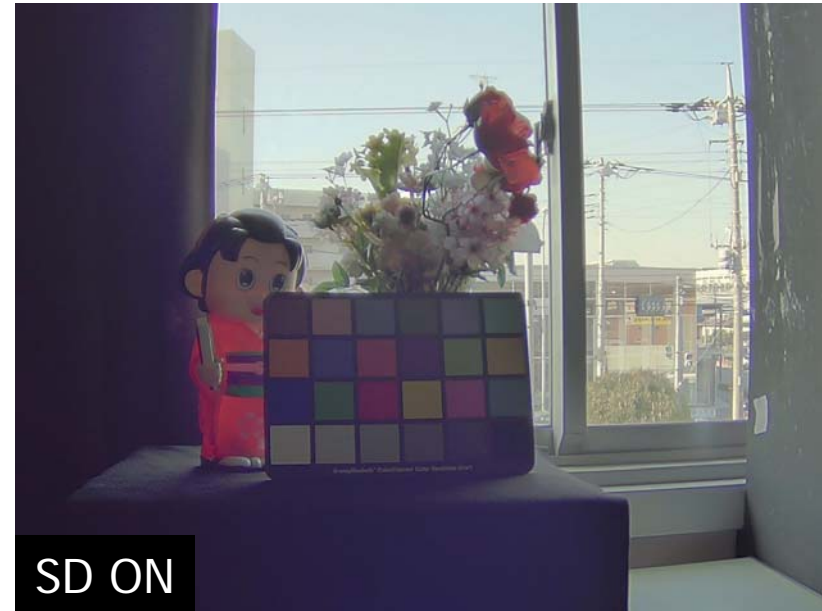
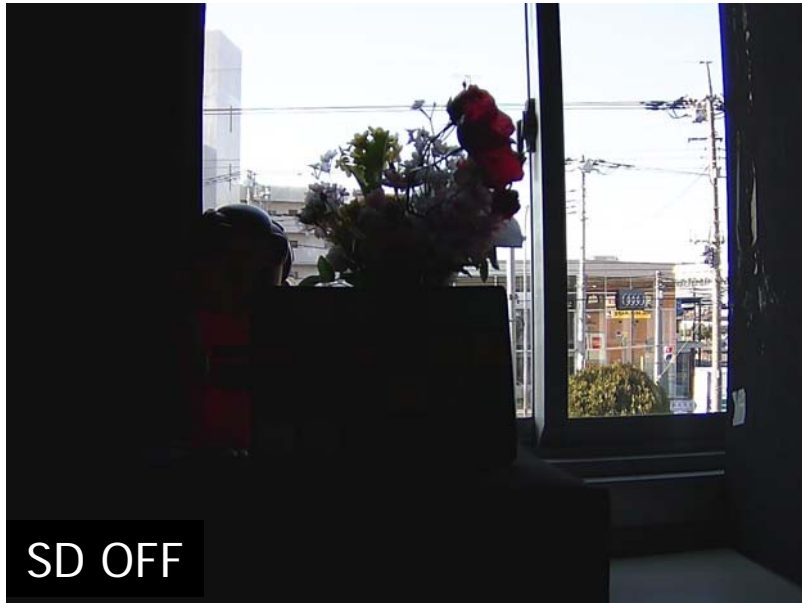

The brightness of face will be calibrated automatically.

Super Dynamic and Face detection : ON

we can clearly recognize a human face and outside.

VIQS = Variable Image Quality on Specified area

is the technology that varies compression rate and image quality on specified area.



Usage

(1) To reduce total bitrate or network bandwidth with keeping image quality on specified area

(2) To improve image quality on specified area with keeping total bitrate or network bandwidth

User Benefit

To save Hard Disk Drive capacity
To save network bandwidth

How to Setup VIQS (1)

i-PRD
SmartHD

(1) Determine the average (total) bitrate

The screenshot shows the web interface for a WV-SW355 Network Camera. The interface is titled "WV-SW355 Network Camera - Microsoft Internet Explorer". The main content area is divided into two sections: "H.264(1)" and "H.264(2)". The "H.264(1)" section is currently active and contains the following settings:

Setting	Value
H.264 transmission	<input checked="" type="radio"/> On <input type="radio"/> Off
Internet mode (over HTTP)	<input type="radio"/> On <input checked="" type="radio"/> Off
Image capture size	VGA
Transmission priority	Frame rate
Frame rate *	30fps *
Max bit rate (per client)*	Max 512kbps * - Min 4096kbps *
Image quality	Normal
Refresh interval	1s
Transmission type	Unicast port (AUTO)
Unicast port1(Image)	32004 (1024-50000)
Unicast port2(Audio)	33004 (1024-50000)
Multicast address	239.192.0.20
Multicast port	37004 (1024-50000)
Multicast TTL/HOPLimit	16 (1-254)

The "Max bit rate (per client)*" setting is highlighted with a yellow box. Below the "H.264(1)" section, the "H.264(2)" section is partially visible, showing similar settings for H.264 transmission and Internet mode.

Panasonic ideas for life

How to Setup VIQS (2)

i-PRO
SmartHD

(2) Determine the area for higher image quality with mouse dragging

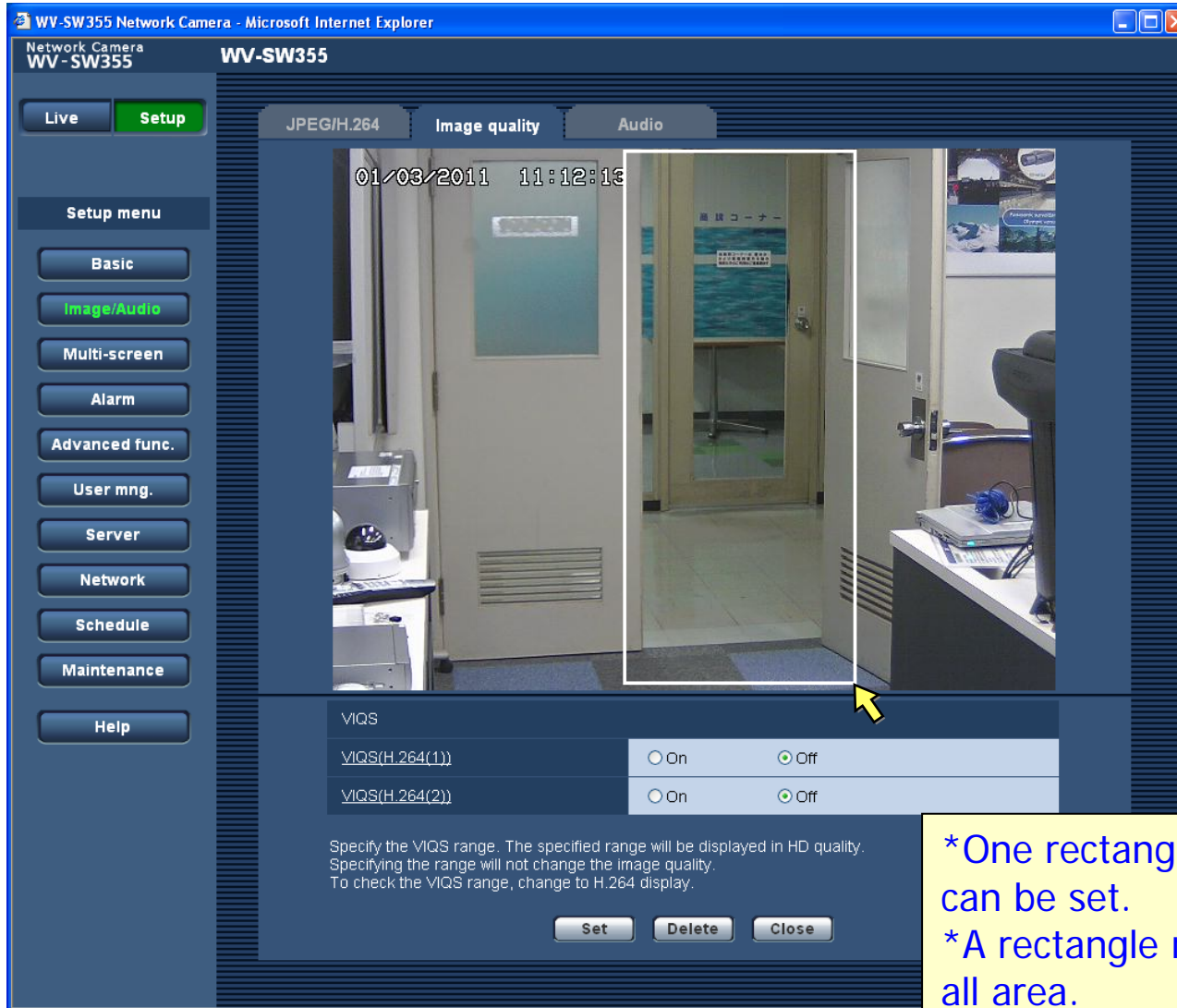

WV-SW355 Network Camera - Microsoft Internet Explorer

Network Camera WV-SW355

Live Setup

JPEG/H.264 Image quality Audio

01/03/2011 11:12:13

Setup menu

- Basic
- Image/Audio
- Multi-screen
- Alarm
- Advanced func.
- User mng.
- Server
- Network
- Schedule
- Maintenance
- Help

VIQS

VIQS(H.264(1))	<input type="radio"/> On	<input checked="" type="radio"/> Off
VIQS(H.264(2))	<input type="radio"/> On	<input checked="" type="radio"/> Off

Specify the VIQS range. The specified range will be displayed in HD quality. Specifying the range will not change the image quality. To check the VIQS range, change to H.264 display.

Set Delete Close

*One rectangle for higher image quality can be set.

*A rectangle needs to be less than 40% of all area.

Panasonic ideas for life

How to Setup VIQS (3)

i-PRO
SmartHD

(3) Check VIQS "On" in the menu which you want to apply VIQS.

The screenshot shows the web interface for a WV-SW355 Network Camera. The browser title is "WV-SW355 Network Camera - Microsoft Internet Explorer". The page has a "Live" button and a "Setup" button. Under "Setup menu", there are buttons for "Basic", "Image/Audio", "Multi-screen", "Alarm", "Advanced func.", "User mng.", "Server", "Network", "Schedule", "Maintenance", and "Help". The "Image/Audio" menu is selected, showing a live video feed of an office interior. Below the video feed, the "VIQS" section is visible. It contains two rows: "VIQS(H.264(1))" with "On" selected and "Off" unselected, and "VIQS(H.264(2))" with "Off" selected and "On" unselected. A mouse cursor is pointing at the "On" radio button for stream 1. Below the radio buttons, there is a note: "Specify the VIQS range. The specified range will be displayed in HD quality. Specifying the range will not change the image quality. To check the VIQS range, change to H.264 display." At the bottom of the VIQS section are "Set", "Delete", and "Close" buttons.

* VIQS can be applied to only H.264 stream.
* Higher image quality area is common between stream 1 and stream 2.

Panasonic ideas for life

Comparison of Image Quality (1)

i-PRO
SmartHD

Without VIQS, **768kbps/VGA/30ips**



With VIQS, **512kbps/VGA/30ips**



*There is no frame in actual image

Non-specified area

Without VIQS



With VIQS



Specified area

Without VIQS



With VIQS



Panasonic ideas for life

Comparison of Image Quality (2)

i-PRO
SmartHD

Without VIQS, 768kbps/VGA/30ips



With VIQS, 768kbps/VGA/30ips



*There is no frame in actual image

Without VIQS



With VIQS



Panasonic ideas for life

Consideration for Bitrate and Compression

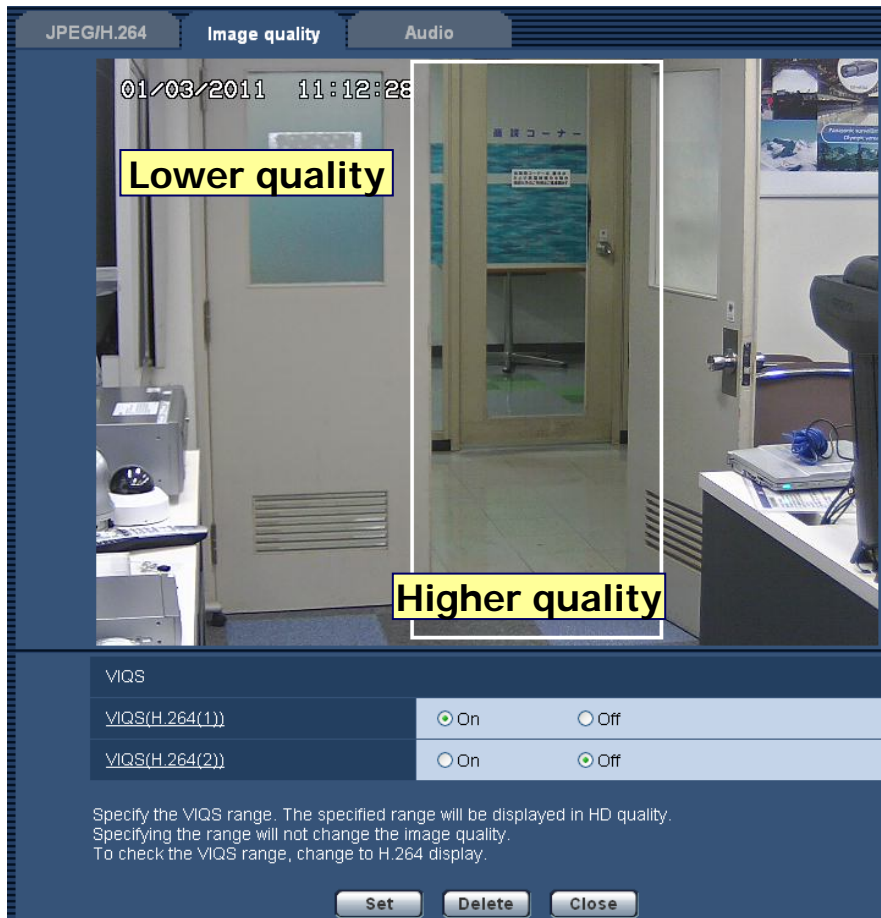

- Picture quality for higher image quality area will be one step higher than the average (total) bit rate.
- Picture quality for lower image quality area will be one step lower than the average (total) bit rate.

:
 :
 1536kbps
 1024kbps
 768kbps ← picture quality for higher area
 512kbps ← the average (total) bit rate
 384kbps ← picture quality for lower area
 256kbps
 :
 :

the average (total) bit rate
512kbps

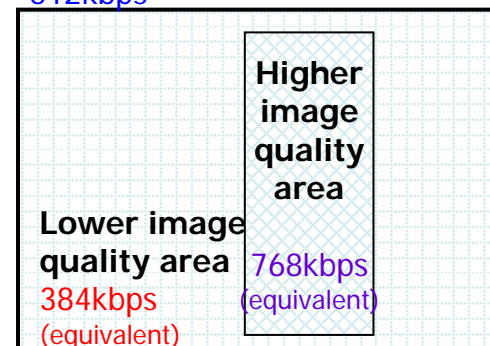

- One rectangle for higher quality area can be set.
- A rectangle need to be less than 40% of all area.
- Effect of VIQS will be not visible in setup menu.
(Above picture is just a image for explanation.)

Summary of VIQS

i-PRO
SmartHD

(1) To improve image quality on specified area with keeping total bitrate or bandwidth

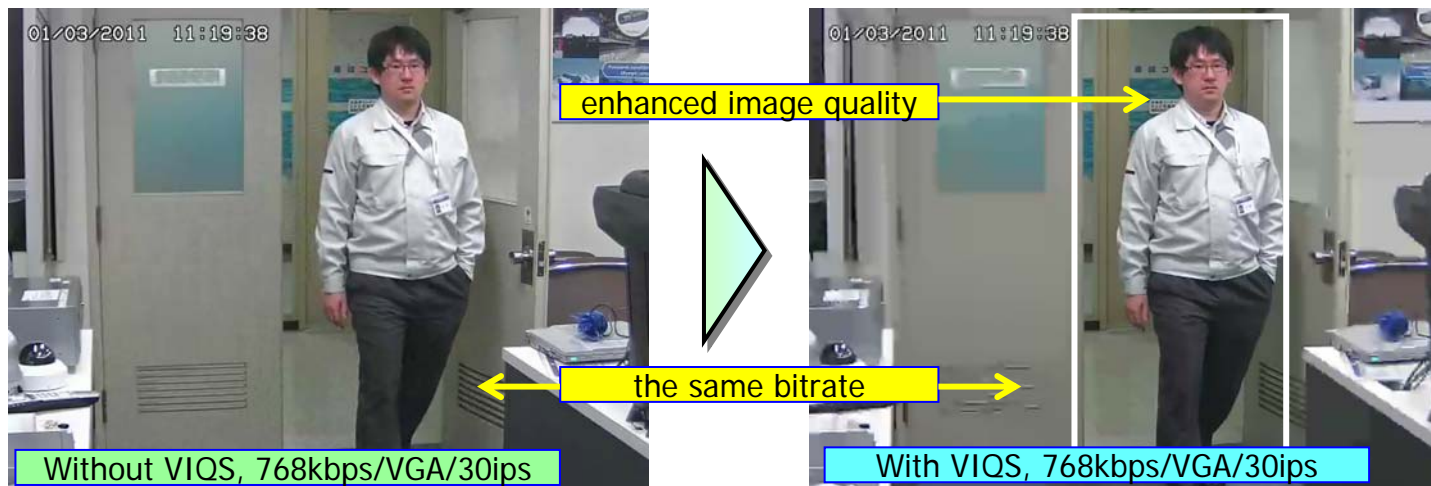

(2) To reduce total bitrate or bandwidth with keeping image quality on specified area

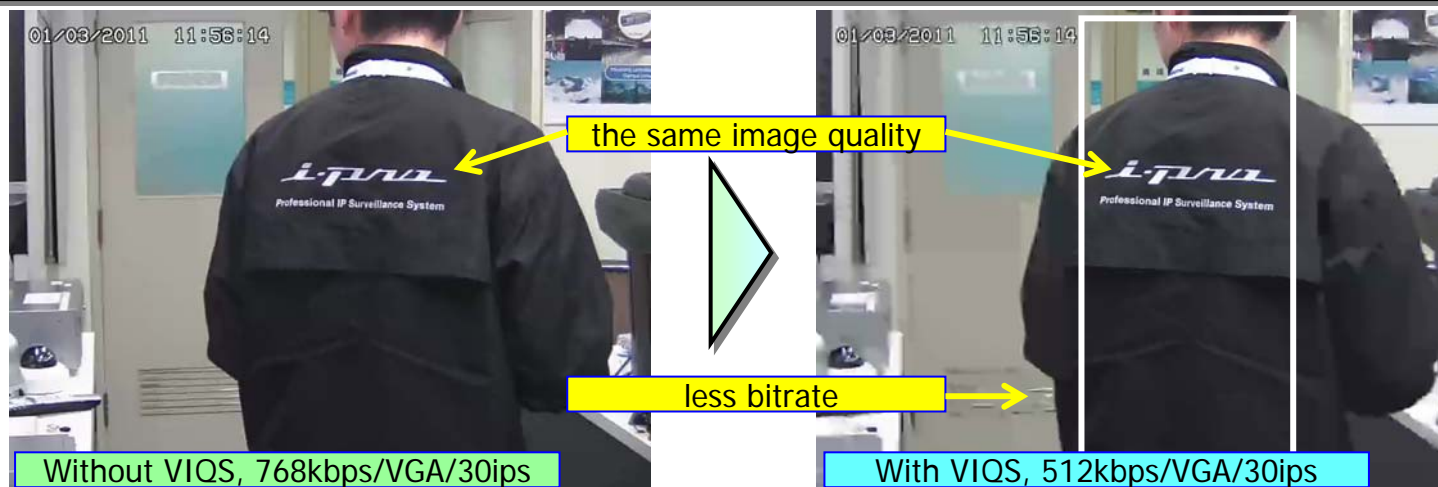

Panasonic ideas for life

Lens Mount (Built-In Lens & Extra Optical Zoom)

Built in Lens

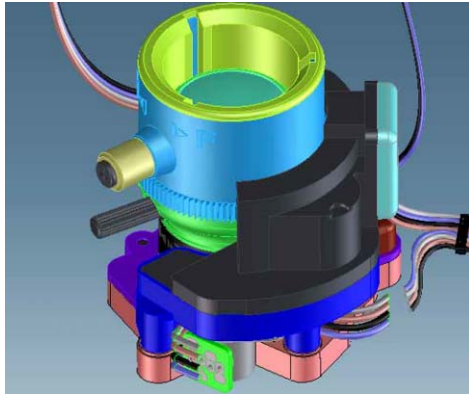

SW355/352 has New Built-In type Lens
(F1.6 2.8mm-10mm 3.6x with Day/Night)

* NW484/NW502 can change the Lens to long focal length type.

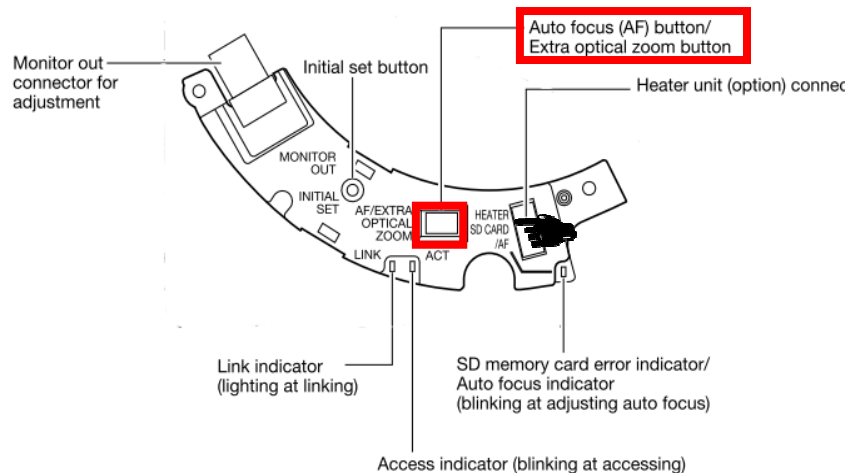

Do you want to use Long focal length lens ?

Hold down the auto focus (AF) button/extra optical zoom button for 5 seconds or more.

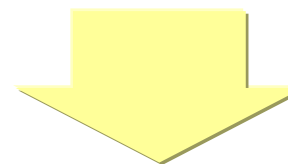

2x extra optical zoom will be applied.
When using VGA output, you can get same effect with using 20mm Lens.

Extra Optical zoom => This function can provide long focal length as follows
ON : F1.6 2.8 mm-20 mm * VGA only
OFF: F1.6 2.8 mm-10 mm

Extra Optical Zoom

Using VGA output, Extra zoom function can provide a picture image of 2 times

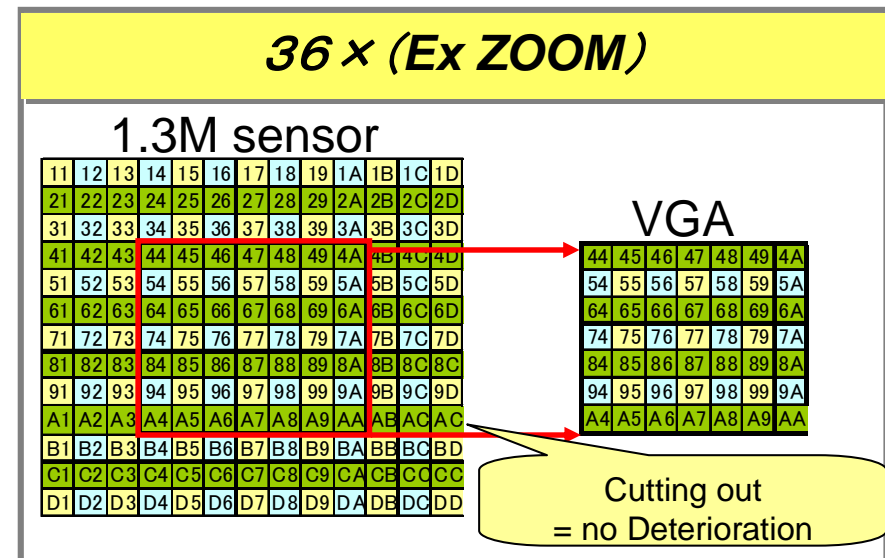
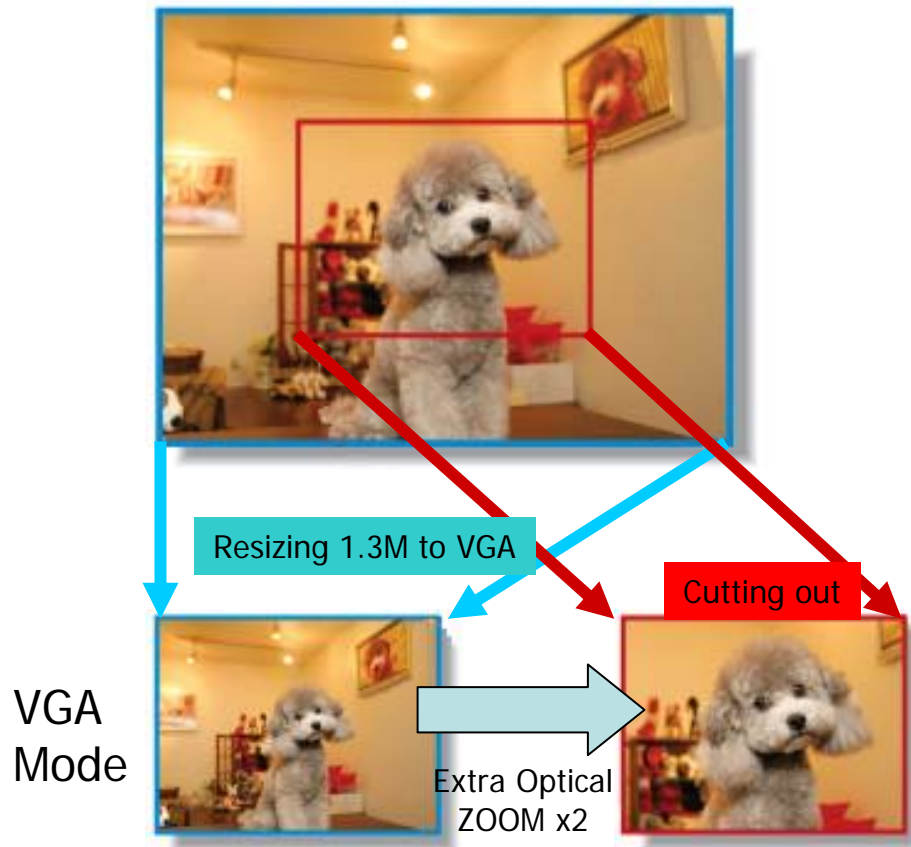

SD Memory Recording

i-PRO
SmartHD

SD/SDHC Memory card slot for manual recording (H.264/JPEG), alarm recording (H.264/JPEG) and backup upon network failure (JPEG).

SD Memory Setting



1. Select image format

- JPEG
- H.264
- * In case of H.264, H.264 (2) streaming is used.

2. Select recording mode

- JPEG :Manual REC/Alarm REC (Post)
/Backup upon network failure (FTP error)
- H.264 :Manual REC/Alarm REC (Pre/Post)

3. Select recording setting

- Resolution :
 - 4:3 mode :1280x960/VGA/QVGA
 - 16:9 mode :1280x720/640x360/320x180
- Frame Rate/Bit Rate
- * In case of H.264, follow H.264 (2) settings and up to VGA (4:3 mode) or 640x360 (16:9 mode).

4. Select data size setting in pre/post alarm for H.264

- Pre-Alarm :ON (data size: up to 2Mbps)/OFF
- Post-Alarm:10s – 300s

Panasonic ideas for life

UniPhier (Original System LSI)

- Multiple H.264 High Profile Streams
- Real Time HD Video Processing
- On-device Intelligence Support



H.264 profiles

H.264 High Profile encoding with Panasonic Uniphier LSI enables 1280 x 960 high quality real time video with smaller data size.

UniPhier H.264 High Profile

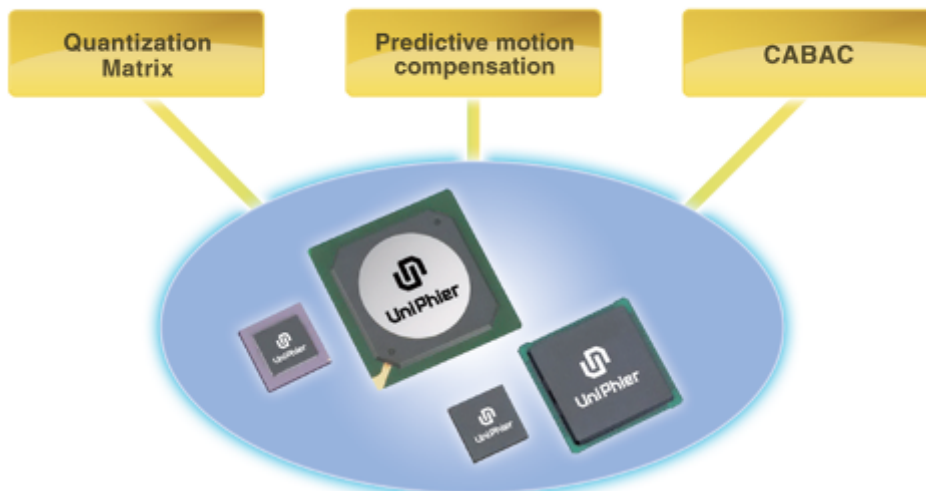

1280x960 comparison		VGA comparison	
JPEG 11.5Mbps	1280 x 960 11 ips JPEG	MPEG-4 2 Mbps	VGA 30 ips
JPEG quality mode = 5			
H.264 4 Mbps	1280 x 960 30 ips H.264	H.264 1 Mbps	VGA 30 ips

* Superior image and high frame rate with smaller data size.

High Definition

i-PRO
SmartHD

It improves picture resolution from standard definition to high definition.



Analog Camera

i-Pro SmartHD Camera



Panasonic ideas for life

Progressive Scan

i-PRD
SmartHD

Progressive video output ensures clear images with less motion blur and no tearing even when the subject is moving.

Interlace scan



Image appears with tearing when the subject is moving due to temporal difference between odd/even field.

Progressive scan



There is no tearing even when the subject is moving.

Panasonic ideas for life

Face Detection

i-PRO
SmartHD

It automatically detects up to 8 faces, and transfers face data as XML.
It enables to develop custom applications such as NV200 recorder.

Automatic Face Detection



* Face detection is not handled as an alarm source.

Panasonic ideas for life

Mega Super Dynamic with face detection *i-PRD* SmartHD

The brightness of face will be automatically calibrated by face detection in backlit condition.



Super Dynamic OFF



Super Dynamic ON

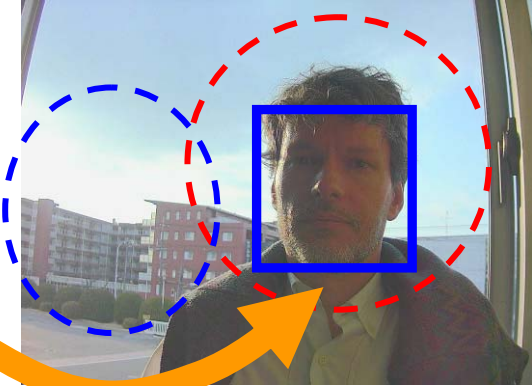

Face Detection: ON (blue square)

Before Calibration

Face is difficult to be recognized because of backlit. Camera is adjusted from bright section circled in blue.

After Calibration

Overall brightness level is increased without causing the saturation in the originally bright section (blue circle).

High Sensitivity

i-PRO
SmartHD

It improves low illumination performance even in darker condition.



Conventional HD Camera



i-Pro SmartHD Camera

* SW335/352 supports high sensitivity.

Panasonic ideas for life

Lens ABF

i-PRO
SmartHD

SW355/352 has lens ABF function which is very useful for easy installation.
Lens ABF means just "Auto Focus."

After pushing "Execute" button, focus adjustment will run automatically.

The image shows two browser windows. The left window, titled 'Focus - Microsoft Internet Explorer', displays a 'Focus' menu with 'Auto' selected. The 'Execute' button is circled in red. Below it are 'Near', 'Reset', and 'Far' buttons, and a 'Close' button at the bottom. The right window, titled 'WV-SF336 Network Camera - Microsoft Internet Explorer', shows the camera's main interface. The 'Setup' button is highlighted in green. A 'Setup menu' on the left includes 'Image/Audio', 'Multi-screen', 'Alarm', 'Advanced func.', 'User mng.', 'Server', 'Network', 'Schedule', 'Maintenance', and 'Help'. The main video area shows two white cars on a road. A 'NEAR FAR INDICATOR 55 FOCUSING' overlay is visible at the bottom of the video. Below the video, there are 'Image adjust', 'Focus', and 'Privacy zone' sections, each with a 'Setup >>' button.

* SW355/352 supports lens ABF function.

Panasonic ideas for life

Day-Night

i-PRG
SmartHD

Day-Night function automatically switches camera from color to B/W and vice versa depending on the illumination, an ideal solution for 24-hour surveillance.

With moving IR cut filter and Lens ABF, both high sensitivity and accurate focus are ensured.

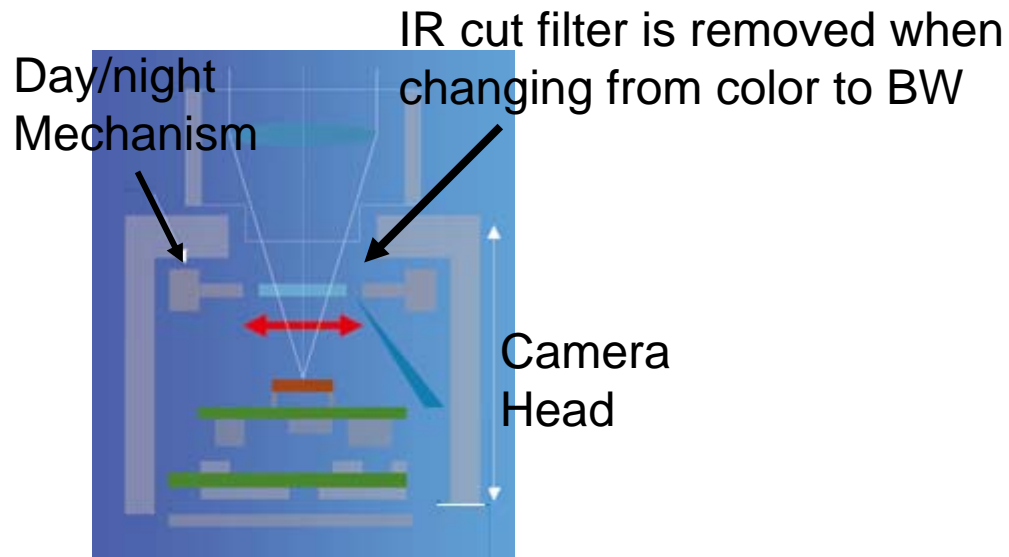

Adaptive DNR (Digital Noise Reduction)

i-PRG
SmartHD

2D-DNR for motion area and 3D-DNR for static area are effectively combined, realizing a clear low noise image with less motion blur and resolution deterioration.



AGC OFF: Image is too dark



AGC ON: Image is too noisy.



Conventional DNR:
Motion blur on moving subject.



Motion adaptive DNR:
Clear image without motion blur.

Panasonic ideas for life

H.264 Latest Encoding - 1

i-PRO
SmartHD

H.264 latest encoding technology with Panasonic Uniphier platform enables superior image of 1280 x 960 with smaller data size.

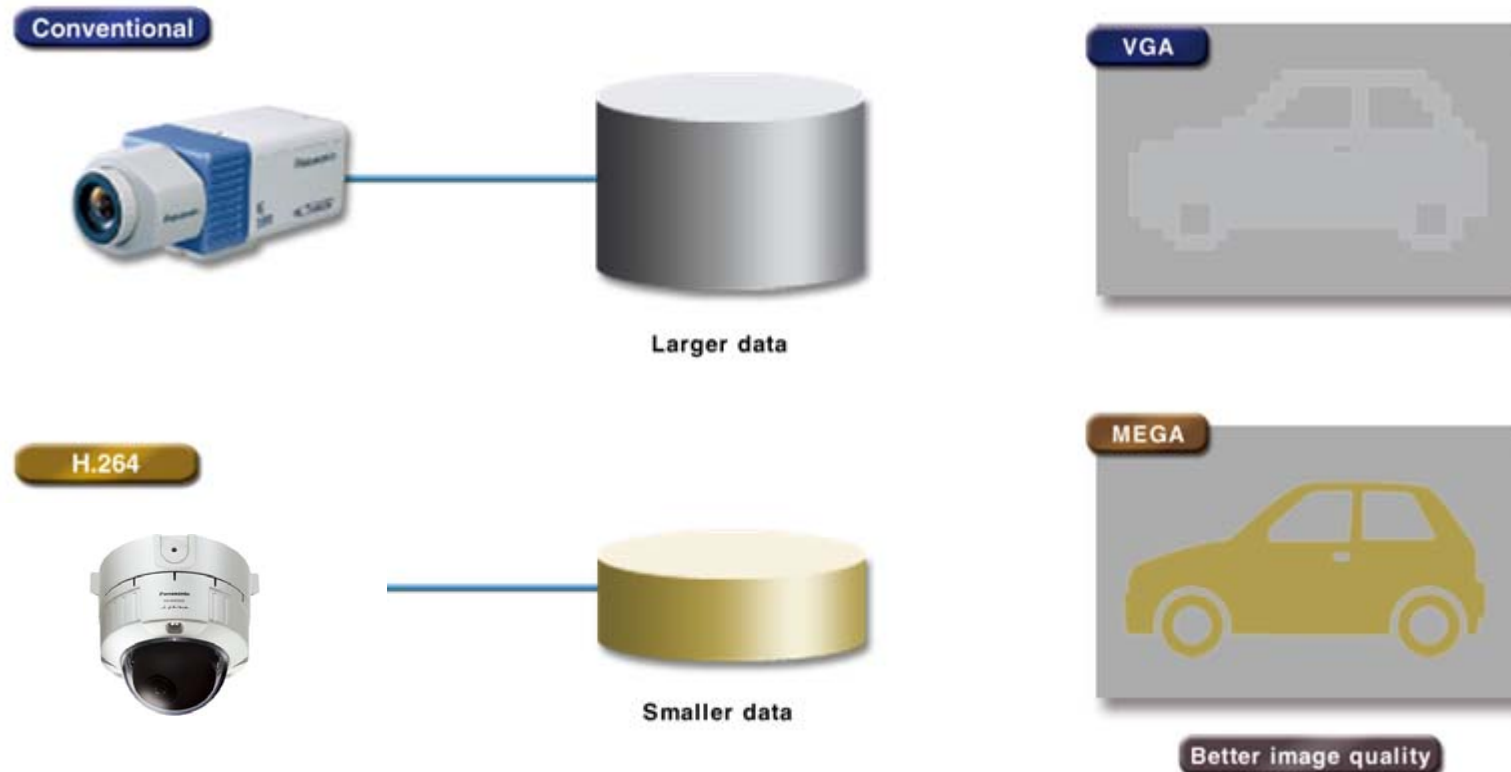

* This allows better image quality within the limited network/disk capacity.

Panasonic ideas for life

H.264 Latest Encoding - 2

i-PRO
SmartHD

H.264 latest encoding technology with Panasonic Uniphier platform enables superior image of 1280 x 960 with smaller data size.

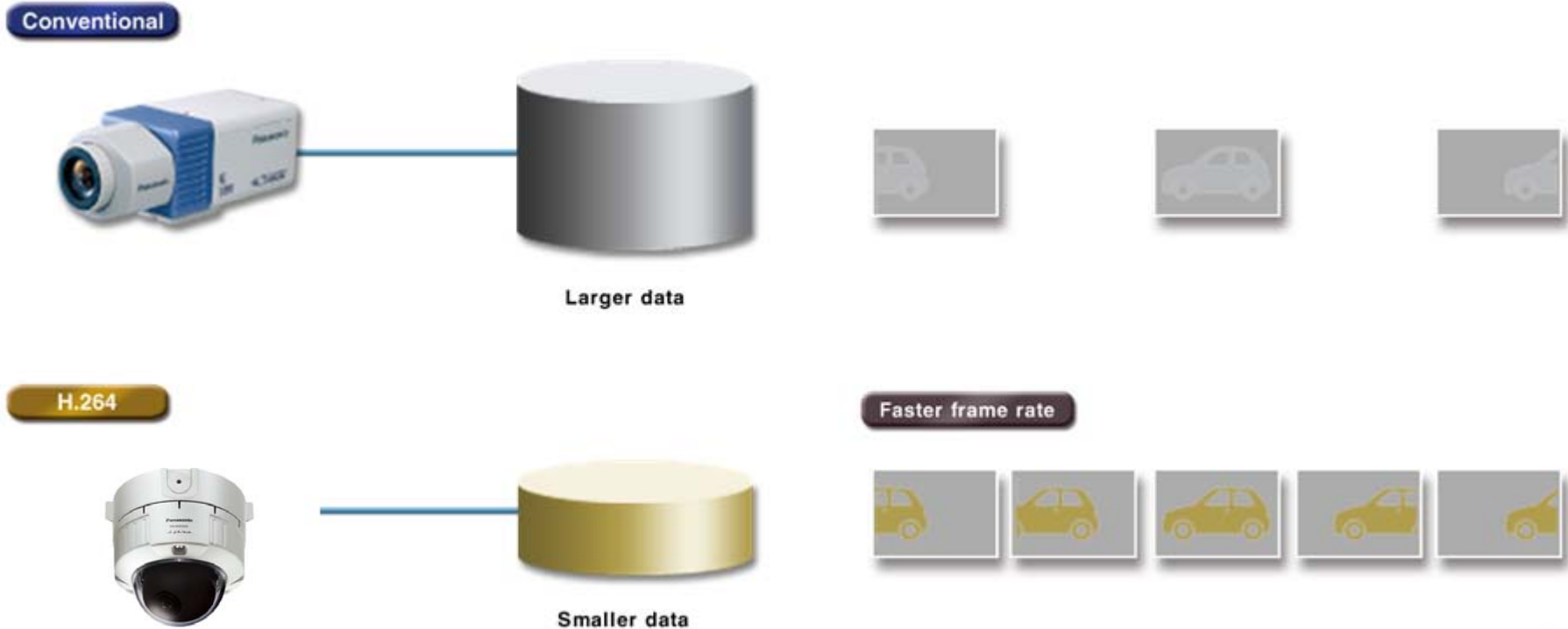

* This allows faster frame rate within the limited network/disk capacity.

H.264 Latest Encoding - 3

i-PRO
SmartHD

H.264 latest encoding technology with Panasonic Uniphier platform enables superior image of 1280 x 960 with smaller data size.

Conventional

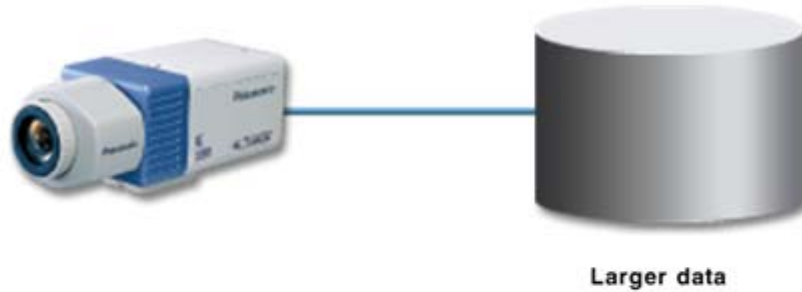

H.264



Longer recording time



* This allows longer recording time within the limited disk capacity.

Panasonic ideas for life

Frame Rate Priority Mode

Frame rate priority mode dynamically controls bit rate depending on the subject to maintain the frame rate.

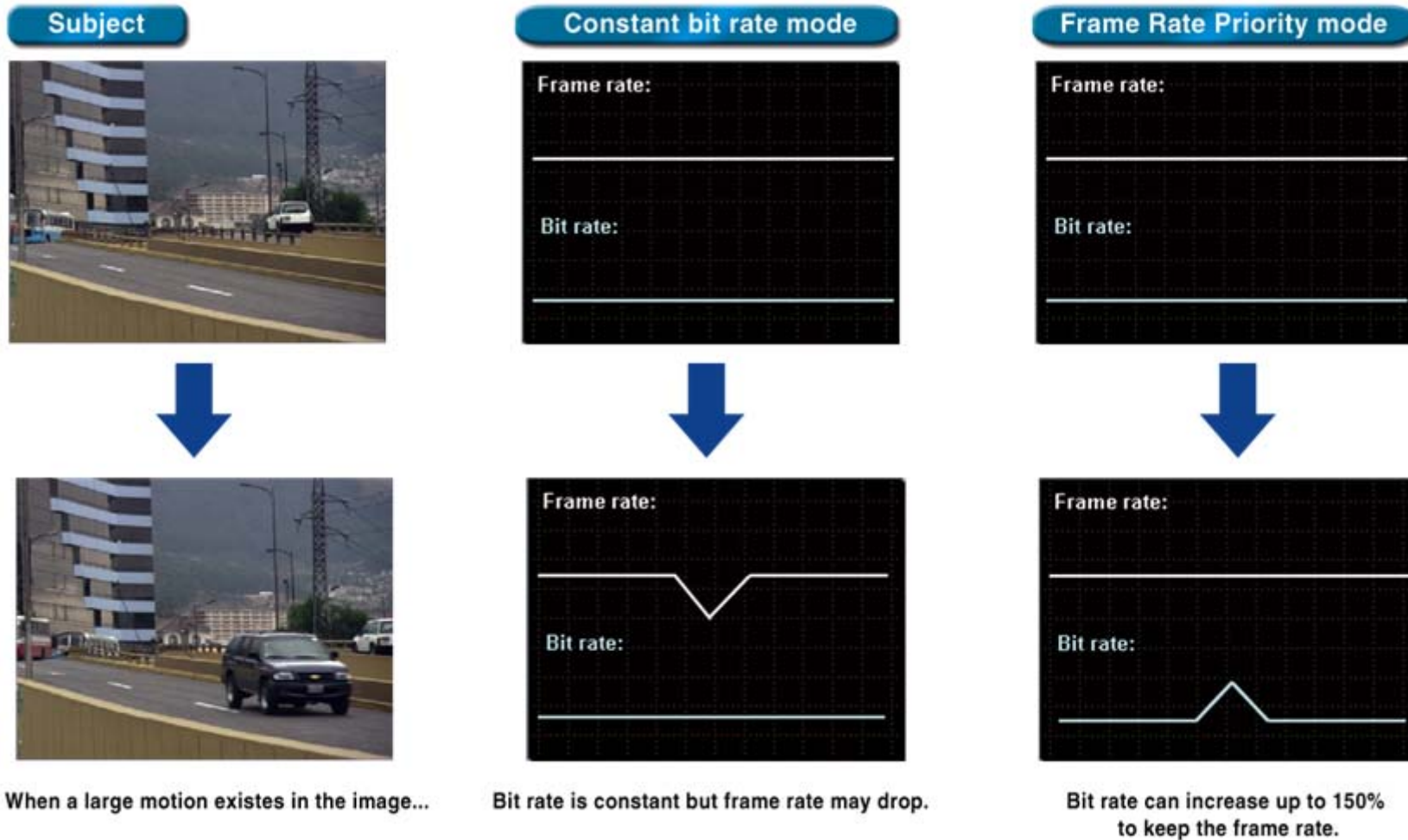

* This mode does not always guarantee the frame rate.

Multiple Streaming – 4:3 ratio

i-PRO
SmartHD

Triple streams(4:3 aspect ratio) including JPEG and H.264(2ch) or MPEG4(2ch) can be transmitted simultaneously, enabling both real time monitoring and high quality recording.

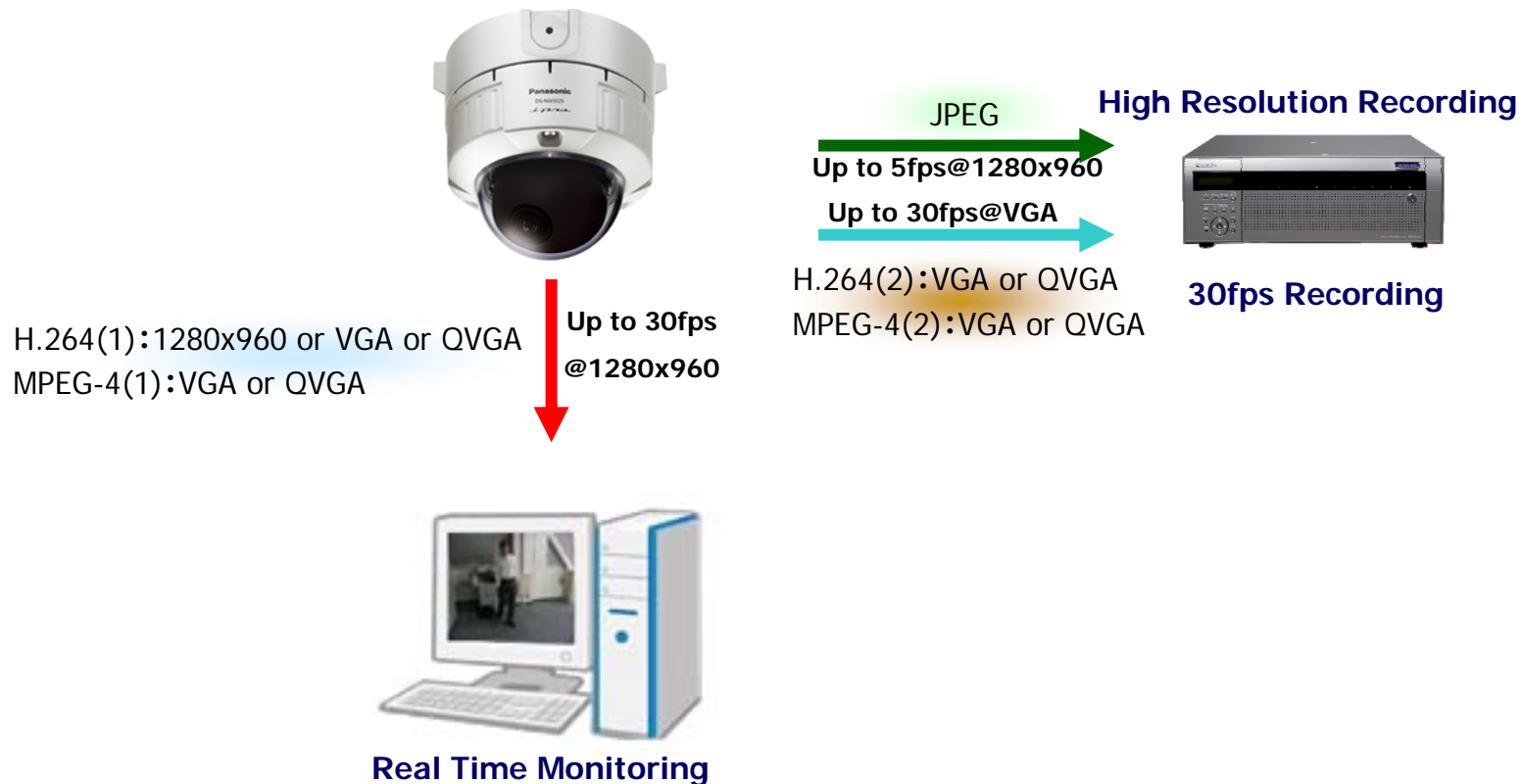

* When motion stream 1 is H.264 or MPEG-4, motion stream 2 must be H.264 or MPEG-4 (same compression type).
Total bit rate must be less than camera's max performance. Detail of the streaming combination is under study.

Panasonic ideas for life

Multiple Streaming – 16:9 ratio

i-PRO
SmartHD

Triple streams(16:9 aspect ratio) including JPEG and H.264(2ch) can be transmitted simultaneously, enabling both real time monitoring and high quality recording.

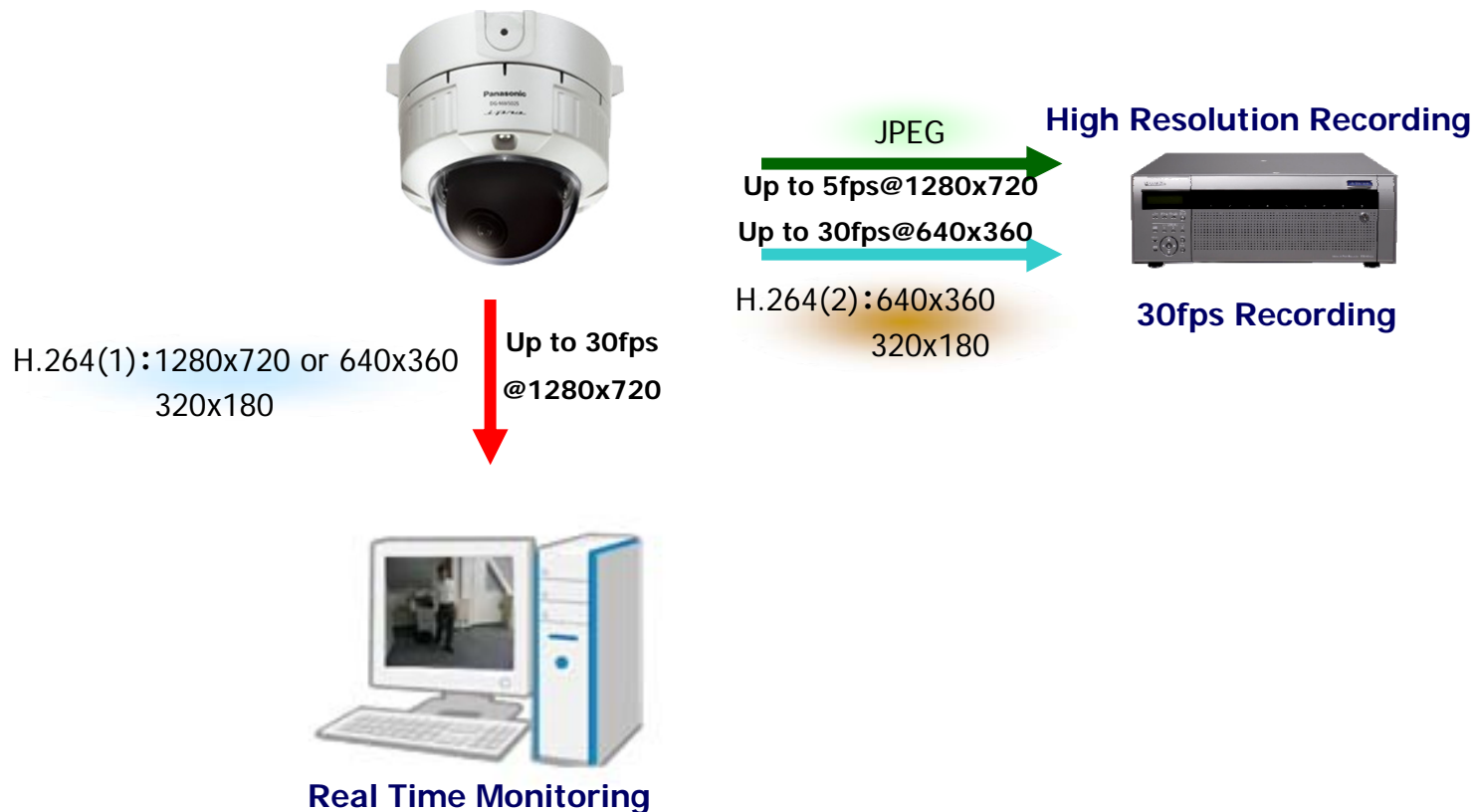

* Total bit rate must be less than camera's max performance. Detail of the streaming combination is under study.

Panasonic ideas for life

Video Motion Detection

The motions in the specified areas can be detected, triggering an alarm.

Up to 4 areas can be registered. Finer tuning is possible with area and sensitivity adjustment.

Up to 4 areas can be set.

Detection size; When smaller, sensitivity becomes higher.

Area	1(White)	2(Blue)	3(Green)	4(Red)
Status	<input type="radio"/> On <input type="radio"/> Off	<input type="radio"/> On <input type="radio"/> Off	<input type="radio"/> On <input type="radio"/> Off	<input type="radio"/> On <input type="radio"/> Off
Detection area	<input type="range" value="1"/>	<input type="range" value="1"/>	<input type="range" value="1"/>	<input type="range" value="1"/>
Detection sensitivity	<input type="range" value="5"/> Low High	<input type="range" value="5"/> Low High	<input type="range" value="5"/> Low High	<input type="range" value="5"/> Low High
Delete	<input type="button" value="Delete"/>	<input type="button" value="Delete"/>	<input type="button" value="Delete"/>	<input type="button" value="Delete"/>
Light detection control	<input type="radio"/> On <input checked="" type="radio"/> Off			
<input type="button" value="Set"/>				
VMD information addition	<input type="radio"/> On <input checked="" type="radio"/> Off			
<input type="button" value="Set"/>				

Sensitivity: Low to High

Flexible alarm handling

i-PRO
SmartHD

Alarm sources including Terminal input, VMD and Panasonic alarm command can trigger actions such as SD memory recording, FTP image transfer, E-mail notification, Indication on browser, Alarm terminal output, and Panasonic protocol output.



PoE (Power over Ethernet)

i-PRO
SmartHD

Both power and image data can be transmitted through a signal Ethernet cable.

By eliminating the need for power cables and supplies when installing cameras or changing layouts, installation and maintenance costs are reduced.

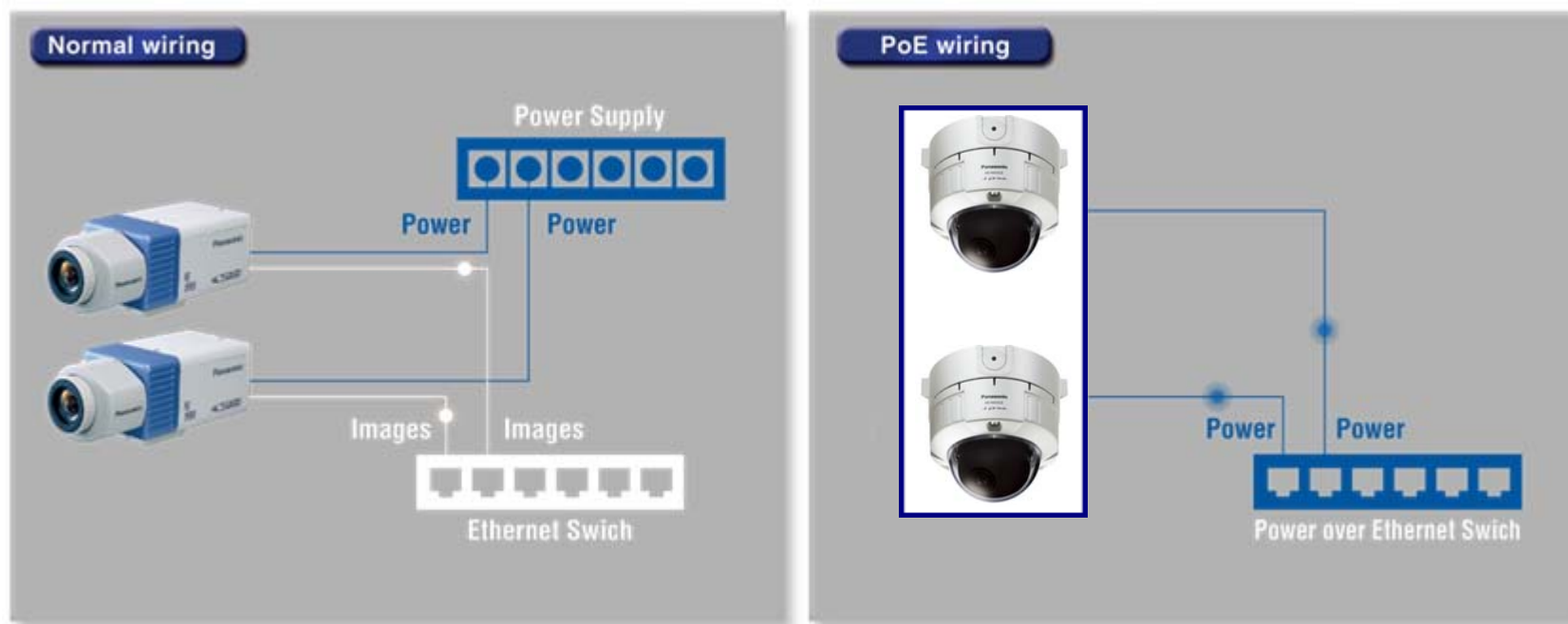

* SW355/352 supports Power over Ethernet .

Bi-directional Audio

i-PRO
SmartHD

Full duplex bi-directional audio allows interactive communication between camera site and monitoring site.

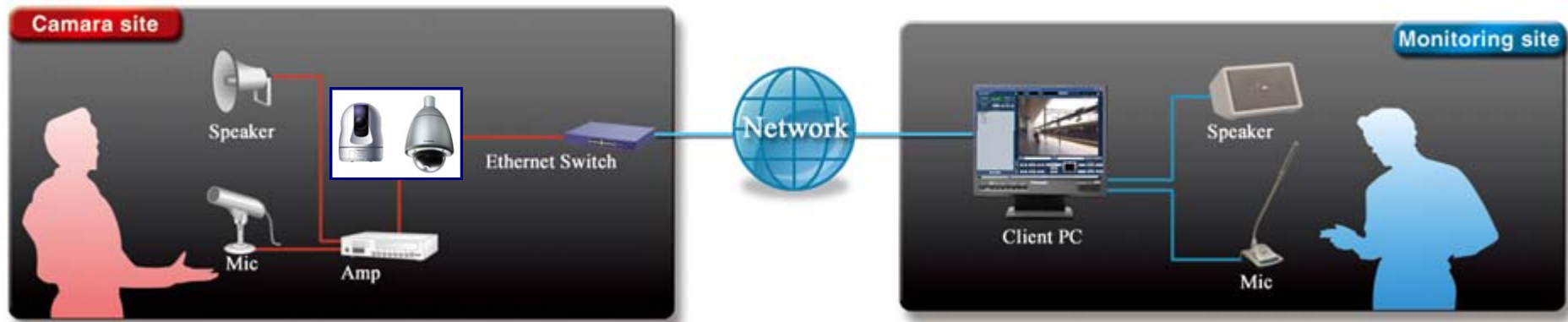

* G.726 (ADPCM) 32 kbps & 16 kbps and G.711.



overview

Network and Software Feature

i-PRO
SmartHD

New Feature

VIQS (Variable Image Quality on Specified area)



Codec/Transmission

- Multi JPEG image quality setting
- Best effort mode for H.264/MPEG-4
- G.711 and G.726 (for Audio)

Network

- Onvif ver1.01
- HTTPS
- DDNS (Viewnetcam/Dynamic DNS Update/Dynamic DNS Update(DHCP))
- CGI (i-pro & BB series)
- UPnP
- Auto-IP

Other

- SD memory card recording (H.264) with schedule
- Cellular Phone

"LIVE page" operation window

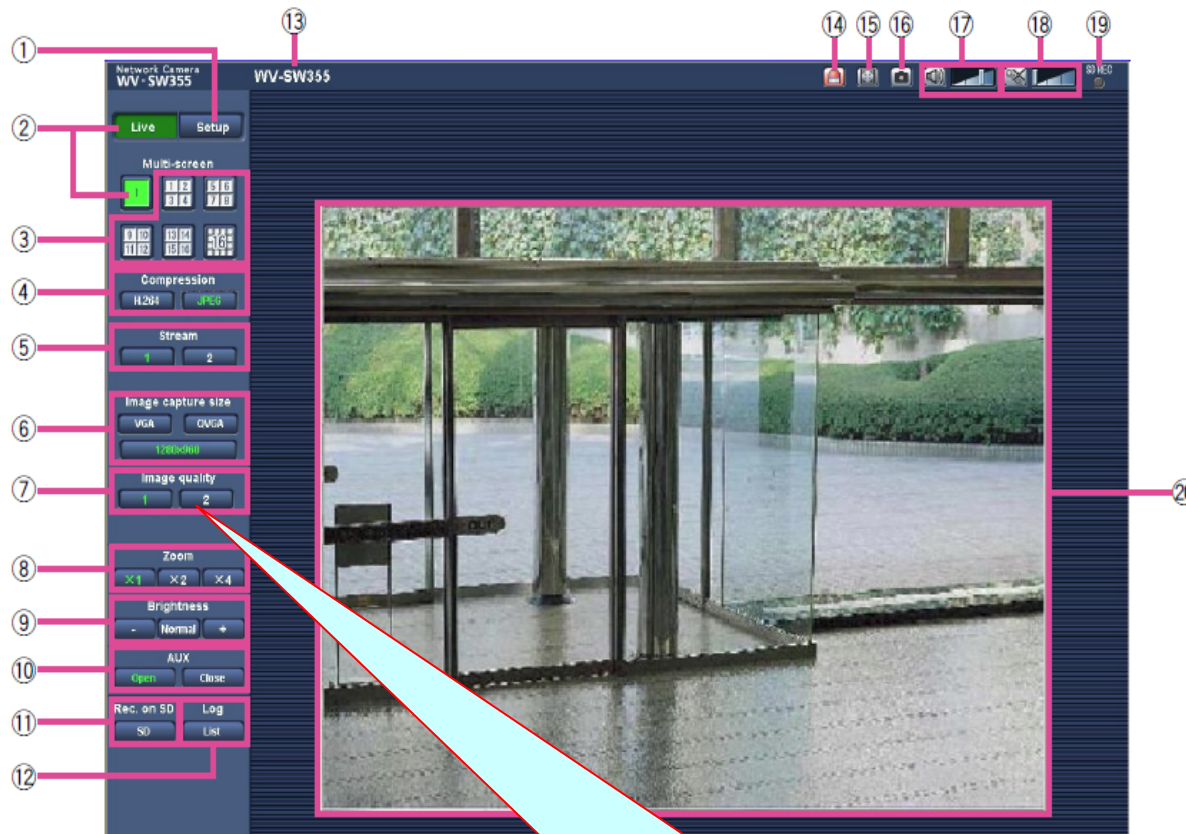

1	[Setup] button
2	[Live] button
3	[Multi-screen] buttons
4	[Compression] buttons
5	[Stream] button
6	[Image capture size] buttons
7	[Image quality] buttons
8	[Zoom] buttons
9	[Brightness] buttons
10	[AUX] buttons
11	[Rec. on SD] buttons
12	[Log] button
13	Camera title
14	Alarm button
15	Full screen button
16	Snap shot button
17	Mic input button
18	Audio output button
19	SD recording status indicator

[Image quality] buttons
Select two types of image quality of JPEG images for each image capture size.

VIQS function

It is possible to enhance the image quality of the specified range within a target area (image).
It is also possible to moderate the image data size by lowering the image quality of other areas.
The VIQS setting is available only for H.264 images.
When checking the images after configuring the VIQS setting, display the H. 264 images on the "Live" page.

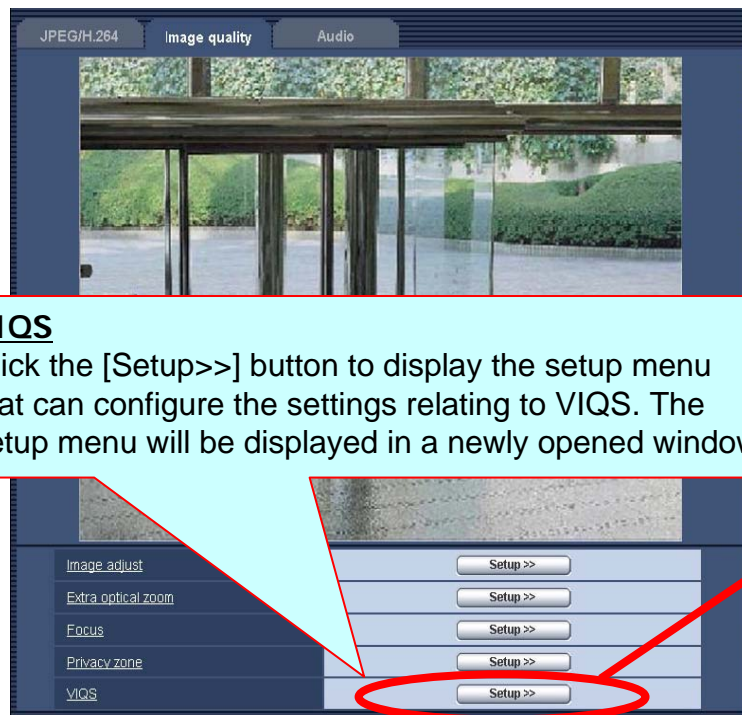

VIQS
Click the [Setup>>] button to display the setup menu that can configure the settings relating to VIQS. The setup menu will be displayed in a newly opened window.

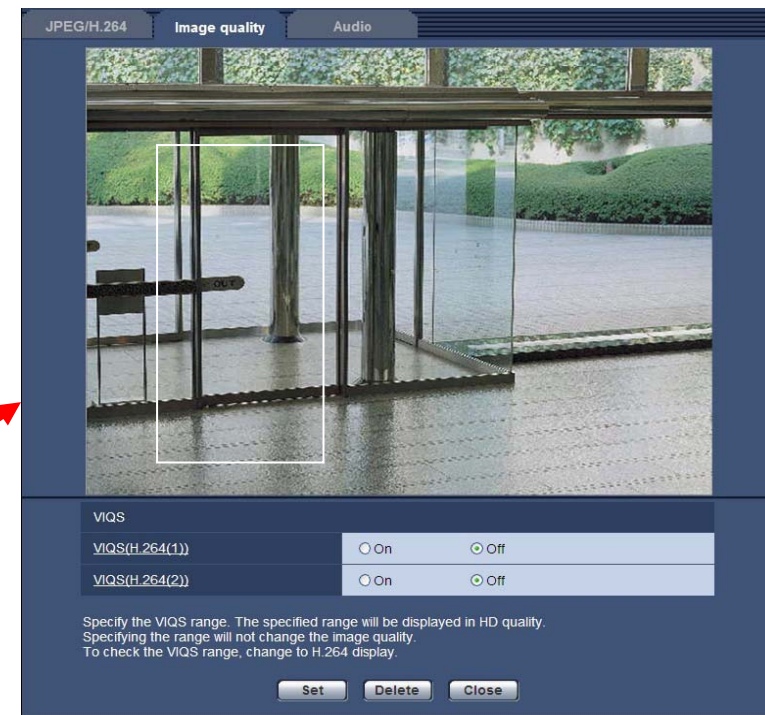

Capture Size/JPEG multi quality

JPEG/H.264 | Image quality | Audio

Aspect ratio: 4:3 (1280x960 / VGA / QVGA)

Set

JPEG

"Live" page (Initial display)

Refresh interval (JPEG) *: 5fps

Image capture size: 1280x960

Image quality: Quality1

Image quality setting

Resolution	Quality1	Quality2
1280x960	5 Normal	8
VGA	5 Normal	8
QVGA	5 Normal	8

Set

Can select 4:3/16:9
SW355
[4:3] 1280x960/640x480/320x240
[16:9] 1280x720/640x360/320x180
SW352
[4:3] 800x600/640x480/320x240
[16:9] 640x360/320x180

Can select two qualities per capture size.
For example, High quality image is used for recording, and low quality image is used for Cellular phone.

Best effort mode(H.264/MPEG-4)

What is “Best effort mode”

In accordance with the network bandwidth, H.264 images will be transmitted with the bit rate varying between the maximum and minimum bit Rates.

The screenshot shows the configuration interface for H.264(1) with the following settings:

H.264(1)	
H.264 transmission	<input checked="" type="radio"/> On
Internet mode (over HTTP)	<input type="radio"/> On
Image capture size	1280x960
Transmission priority	Best effort
Frame rate *	30fps *
Max bit rate (per client) *	Max 4096kbps * - Min 1024kbps*
Image quality	Normal
Refresh interval	1s

Best effort
Can select Bit rate, Frame rate, and **Best effort**.
In accordance with the network bandwidth, images will be transmitted with the bit rate varying between the maximum and minimum bit Rates

Therefore, if the camera is accessed by many users within total bit rate, the camera will send the stream data of lower bit rate depending on the number of users automatically.

But there is a limitation regarding the accessible number of users.

Please refer the table of next page.

Best effort mode(Accessible number)

The following table describes an accessible number of H.264.

This accessible number is defined by result of calculation and real test including audio stream, command data, JPEG stream.

H.264 bit rate setting	Total bit rate setting (from network setting page)							
	64 kbps	128 kbps	256 kbps	512 kbps	1024 kbps	2048 kbps	4096 kbps	Unlimited
1536 kbps	0	0	0	0	0	1	3	10

Transmission priority : Constant bit rate (Before)

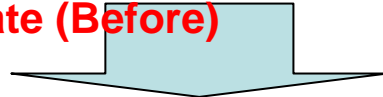

Max 1536 kbps Min 64 kbps	0	1	2	4	9	12	12	12
------------------------------	---	---	---	---	---	----	----	----

Transmission priority :Best effort (After)

H.264 bit rate setting	Total bit rate setting (from network setting page)							
	64 kbps	128 kbps	256 kbps	512 kbps	1024 kbps	2048 kbps	4096 kbps	Unlimited
4096 kbps	0	0	0	0	0	0	1	4

Transmission priority : Constant bit rate (Before)

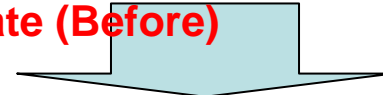

Max 4096 kbps Min 64 kbps	0	1	2	4	9	12	12	12
------------------------------	---	---	---	---	---	----	----	----

Transmission priority :Best effort (After)

HTTPS/DDNS

HTTPS
Self-signed Certificate and CA Certificate can be used.

<u>HTTPS</u>			
<u>CRT key generate</u>		<input type="button" value="Execute"/>	
<u>Self-signed Certificate</u>	Generate	<input type="button" value="Execute"/>	
	Information	Not generated	<input type="button" value="Confirm"/> <input type="button" value="Delete"/>
<u>CA Certificate</u>	Certificate Signing Request generate	<input type="button" value="Execute"/>	
	CA Certificate install	<input type="text"/>	<input type="button" value="Browse..."/> <input type="button" value="Execute"/>
	Information	Invalid	<input type="button" value="Confirm"/> <input type="button" value="Delete"/>
<u>Connection</u>		HTTP ▾	
<u>HTTPS port</u>		443 (1-65535)	

Network **DDNS** SNMP FTP img. trans.

<u>DDNS</u>	Viewnetcam ▾
<u>Personal(Camara) URL</u>	http://*****
<u>Your Account Link</u>	https://*****
<u>Access interval</u>	1h ▾

DDNS
Can Select Dynamic DNS Update, Dynamic DNS Update(DHCP), and Viewnetcam.

Other Network function

Network DDNS SNMP FTP img. trans.

IPv4 network

Network Settings Static
Auto

IP address(IPv4) 192 . 168 . 0 . 10

Subnet mask 255 . 255 . 255 . 0

Default gateway 192 . 168 . 0 . 0

Auto-IP
Can Select Static, DHCP, and **Auto**.

UPnP

Auto port forwarding On Off

Camara short cut On Off

Set

UPnP
Can use "Auto port forwarding" function, and "Camera short cut" function.

Common

HTTP port 80 (1-65535)

Line speed Auto

Max RTP packet size Unlimited(1500byte) Limited(1280byte)

HTTP max segment size(MSS) Unlimited(1460byte) Limited(1024byte)

Max RTP packet size
HTTP max segment size(MSS)

	Item	WS func	remarks	SW355
WS Lib	Device Discovery	6	WS base discovery	Yes
	Device Management	44	Camera control, network settings	Yes
	Security-TLS	8	Manage certificate	Yes
	DDNS	2	Set/Get DDNS	Yes
	Media configuration	46	Manage Profile, media setting	Yes
	Metadata	7	Metadata Configuration	Yes
	Imaging configuration	3	Image configuration settings	Yes
	Event Handling	3	Set event	Yes
	Video analytics	0	Analytics Configuration	No
Media Stream	RTPoverRTSPoverHTTP	—	QuickTime defined specification	Yes
	JPEGOVERRTP	—	JPEG over RTP with RTSP	Yes
	G.711	—	G.711 support	Yes
	Multicast AutoStart	—	RTP multicast	Yes
	Meta data	—	Metadata over RTP	Yes
Event	Event Handling	—	Notify, Pull Point (VMD, Notification of the remaining capacity of the SD card)	Yes
Network	DDNS	—	RFC2326 dynamic DNS update	Yes
	Security-TLS	—	Transport level security – TLS (1.1)	Yes
	CHCPv6	—		Yes

H.264 SD memory card recording 1

Basic SD memory card Log

Recording format JPEG H.264

Set

Common

Remaining capacity notification 50%

Save trigger Alarm input

Overwrite Manual Off

Set

Trigger to save images on the SD memory card are following

- Alarm input
- Manual
- Schedule(H.264 only)

H.264 recording setting

Image capture size VGA

Recording priority Constant bit rate Frame rate

Frame rate 30fps *

Max bit rate 1024kbps

Image quality Normal

Refresh interval 1s

H.264 SD memory card recording 2

Alarm input

H.264 recording bit rate 1536 kbps Recording (Memory) Size per an alarm: 6 Mbyte

Pre-alarm recording

Pre alarm Use Not use Pre alarm (Recording) duration 5s

Post alarm (Recording) duration 30s

Set

Post alarm (Recording) duration

Manual

Live page

The manual recording process is shown in three steps:

- A control panel with an 'SD' button circled in red.
- A dialog box titled 'Record on the SD memory card' with 'Start' and 'Stop' buttons circled in red.
- A live page with an 'SD REC' indicator circled in red.

Red arrows indicate the flow from the SD button to the Start button, and from the Start button to the SD REC indicator.

Live page

Schedule

Schedules

Schedule 1 (White) <input type="checkbox"/>	Schedule mode	Off
	Time range	Wed <input type="checkbox"/> Thu <input type="checkbox"/> Fri <input type="checkbox"/> Sat <input type="checkbox"/> Sun <input type="checkbox"/>
Schedule 2	Schedule mode	Off
	H.264 recording	<input checked="" type="checkbox"/>

H.264 schedule recording

Support Cellular Phone

Compatible compression type is only JPEG.

It is possible to get JPEG data from the cellular phone browser via DDNS.



Functions	Outline of functions
Refresh	Refreshes the camera images by pressing the dial key "5".
Resolution control	Changes the image capture size by pressing the dial key "0". * Image in the aspect ratio of "4:3" Changes the image capture size between 320x240 (default) and 640x480. * Image in the aspect ratio of "16:9" Changes the image capture size between 320x180 (default) and 640x360.
Image quality control	It is possible to change the image quality between "Quality1" and "Quality2" (☞ page 9).
AUX control*	Controls the AUX terminal. These buttons will be displayed only when "AUX output" is selected for "Terminal 3" on the setup menu. (☞ Page 66)

Summer time (daylight saving)

Basic | SD memory card | Log

Camera title: WV-SC385

Date/time: 2010 / 07 / 23 17:19:59

Time display format: 24h

Date/time display format: [dropdown]

Summer time (daylight saving): Auto (dropdown menu open: Auto, In, Out, Auto)

NTP/Time zone: [dropdown]

Start time & date: Month: Jan, Day: 1st, Sun, 1, Time: AM

End time & date: Month: Jan, Day: 1st, Sun, 1, Time: AM

Summer time (daylight saving) Auto

When "Auto" is selected for "Summer time", select the time & date for the start time and the date time

Status display

i-PRD
SmartHD

Live Setup

Server
Network
Schedule
Maintenance
Help

System log Upgrade **Status** Default reset

[Status] tab

Hardware self check

Self check	
Hardware1	0000-0000-0000-0000-0000-0000-0000-00
Hardware2	0000-0000-0000-0000-0000-0000-0000-00

The Panasonic IP setting software

i-PRO
SmartHD

Camera list

No.	MAC Address	IPv4 Address	Port No.	Camera Name	Model	IPv4 overlap
1	00-80-45-59-81-89	192.168.0.10	80		SC385	

Search Network Settings Access Camera

IPv4/IPv6
IPv4

Camera List
•i-PRO series
•BB series

Access Camera (open browser)

Select IPv4 or IPv6

Open network settings

Network Settings

Network Settings Static DHCP AutoIP

Port No. 80

IPv4 Address 192 . 168 . 0 . 10

Subnet Mask 255 . 255 . 255 . 0

Default Gateway 192 . 168 . 0 . 1

DNS Auto Manual

Primary DNS 0 . 0 . 0 . 0

Secondary DNS 0 . 0 . 0 . 0

Save Back

life





Basic performance

Image capture size and max frame rate



<Image size and max frame rate>

画像		image capture size			
		4:3	max fps	16:9	max fps
JPEG		(1) 1,280x960* (2) 800x600 (3) VGA (640x480) (4) QVGA (320x240)	30	(1) 1,280x720** (2) 640x360 (3) 320x180	30
Stream 1(*1)	H.264	(1) 1,280x960* (2) 800x600 (3) VGA (640x480) (4) QVGA (320x240)	30	(1) 1,280x720** (2) 640x360 (3) 320x180	30
	MPEG-4	(1) VGA (640x480) (2) QVGA (320x240)	30	—	—
Stream 2(*1)	H.264	(1) 800x600 (2) VGA (640x480) (3) QVGA (320x240)	30	(1) 640x360 (2) 320x180	30
	MPEG-4	(1) VGA (640x480) (2) QVGA (320x240)	30	—	—

*** (1)1,280x960, ** (1)1,280x720: This resolution is compatible with WV-SW355 only.**

Panasonic ideas for life

(*1) Stream1 and Stream2 are Only the selection of 「H.264」・「H.264」 or 「MPEG-4」・「MPEG-4」



H.264 Frame rate (4 : 3)



■ H. 264 Frame rate

4:3 fixed bit rate mode (1User , Audio=OFF, Refresh-Interval=3sec)

Bit rate (kbps)		64	128	256	384	512	768	1,024	1,536	2,048	3,072	4,096	8,192	
Frame rate (ips)	QVGA	Fine	1	2	5	7.5	10	15	15	20	30	30	30	
		Normal	5	10	15	20	25	30	30	30	30	30	30	
		Low	10	15	25	30	30	30	30	30	30	30	30	
	VGA	Fine	1	1	2	3	5	7.5	10	15	15	20	22.5	
		Normal	2	5	7.5	10	15	20	22.5	30	30	30	30	
		Low	3	7.5	10	15	20	30	30	30	30	30	30	
	4VGA	Fine			1	1	2	3	5	7.5	10	15	20	30
		Normal			1	2	3	5	7.5	10	20	25	30	30
		Low			3	5	7.5	10	15	20	30	30	30	30

4:3 Frame rate priority mode (1User , Audio=OFF, Refresh-Interval=3sec)

Bit rate (kbps)		64	128	256	384	512	768	1,024	1,536	2,048	3,072	4,096	8,192	Unlimited
Frame rate (ips)	QVGA	10	15	20	30	30	30	30	30	30	30	30		30
	VGA	3	7.5	10	15	20	30	30	30	30	30	30		30
	4VGA			3	5	7.5	10	15	20	30	30	30	30	30

Frame mode can be selected from the following. 1fps / 3fps / 5fps / 7.5fps / 10fps / 15fps / 20fps / 30fps

Panasonic ideas for life

Notice. These charts are target performance. Performance would be changed by the contrast or the motion in picture. ★

H.264 Frame rate (16 : 9)



■ H. 264 Frame rate

16:9 fixed bit rate mode (1User , Audio=OFF, Refresh-Interval=3sec →1sec ?)

Bit rate (kbps)		64	128	256	384	512	768	1,024	1,536	2,048	3,072	4,096	8,192	
Frame rate (ips)	320 x 180	Fine	1	2	5	7.5	10	15	15	20	30	30	30	
		Normal	5	10	15	20	25	30	30	30	30	30	30	
		Low	10	15	25	30	30	30	30	30	30	30	30	
	640 x 360	Fine	1	1	2	3	5	7.5	10	15	15	20	22.5	
		Normal	2	5	7.5	10	15	20	22.5	30	30	30	30	
		Low	3	7.5	10	15	20	30	30	30	30	30	30	
	1280 x 720	Fine			1	1	2	3	5	7.5	10	15	20	30
		Normal			1	2	3	5	7.5	10	20	25	30	30
		Low			3	5	7.5	10	15	20	30	30	30	30

16:9 Frame rate priority mode (1User , Audio=OFF, Refresh-Interval=3sec →1sec ?)

Bit rate (kbps)		64	128	256	384	512	768	1,024	1,536	2,048	3,072	4,096	8,192	Unlimited
Frame rate (ips)	320 x 180	10	15	25	30	30	30	30	30	30	30	30		30
	640 x 360	3	7.5	10	15	20	30	30	30	30	30	30		30
	1280 x 720			3	5	7.5	10	15	20	30	30	30	30	30

Frame mode can be selected from the following. 1fps / 3fps / 5fps / 7.5fps / 10fps / 15fps / 20fps / 30fps

Panasonic ideas for life

Notice. These charts are target performance. Performance would be changed by the contrast or the motion in picture. ★

MPEG-4 Frame rate



■ MPEG-4 Frame rate

Fixed bit rate mode (1User , Audio=OFF, Refresh-Interval=3sec)

Bit rate (kbps)		64	128	256	384	512	768	1,024	1,536	2,048	3,072	4,096	
Frame rate (ips)	QVGA	Fine	1	2	5	7.5	10	15	15	20	30	30	30
		Normal	2	5	10	15	20	25	30	30	30	30	30
		Low	5	10	20	25	30	30	30	30	30	30	30
	VGA	Fine	1	1	2	3	5	7.5	10	15	15	20	22.5
		Normal	1	2	5	7.5	10	15	15	22.5	30	30	30
		Low	2	5	7.5	10	10	15	20	25	30	30	30

Frame rate priority mode (1User , Audio=OFF, Refresh-Interval=3sec)

Bit rate (kbps)		64	128	256	384	512	768	1,024	1,536	2,048	3,072	4,096	Unlimited
Frame rate (ips)	QVGA	5	10	20	20	30	30	30	30	30	30	30	30
	VGA	3	5	7.5	10	10	15	20	20	30	30	30	30

Frame mode can be selected from the following. 1fps / 3fps / 5fps / 7.5fps / 10fps / 15fps / 20fps / 30fps

Panasonic ideas for life

Notice. These charts are target performance. Performance would be changed by the contrast or the motion in picture. ★

JPEG Frame rate



■ JPEG Frame rate (H. 264/MPEG-4 OFF)

4:3

Picture quality mode		0 (Super fine)	1 (Fine)	2	3	4	5 (Normal)	6	7	8	9 (Low)
1280 x 960	Frame rate	5	6	7	8	10	13	17	21	26	30
	File size (kbyte)	288	256	224	192	160	128	96	80	64	48
	Bit rate (kbps)	13,248	14,131	14,426	14,131	14,720	15,309	15,014	15,456	15,309	13,248
VGA	Frame rate	14	19	23	29	30	30	30	30	30	30
	File size (kbyte)	115	86	72	58	50	43	36	29	25	22
	Bit rate (kbps)	14,812	15,033	15,235	15,474	13,800	11,868	9,936	8,004	6,900	6,072
QVGA	Frame rate	30	30	30	30	30	30	30	30	30	30
	File size (kbyte)	44	40	36	32	28	24	20	16	14	8
	Bit rate (kbps)	12,144	11,040	9,936	8,832	7,728	6,624	5,520	4,416	3,864	2,208

16:9

Picture quality mode		0 (Super fine)	1 (Fine)	2	3	4	5 (Normal)	6	7	8	9 (Low)
1280 x 720	Frame rate	7	8	10	12	15	20	25	28	30	30
	File size (kbyte)	216	192	160	144	120	88	72	56	48	32
	Bit rate (kbps)	12,096	12,288	12,800	13,824	14,400	14,080	14,400	12,544	11,520	7,680
640 x 360	Frame rate	22	27	30	30	30	30	30	30	30	30
	File size (kbyte)	80	64	48	42	36	30	26	22	18	16
	Bit rate (kbps)	8,960	9,728	8,832	9,744	8,640	7,200	6,240	5,280	4,320	3,840
320 x 180	Frame rate	30	30	30	30	30	30	30	30	30	30
	File size (kbyte)	33	30	27	24	21	18	15	12	9	6
	Bit rate (kbps)	7,920	7,200	6,480	5,760	5,040	4,320	3,600	2,880	2,160	1,440

Panasonic ideas for life

Notice. These charts are target performance. Performance would be changed by the contrast or the motion in picture. ★



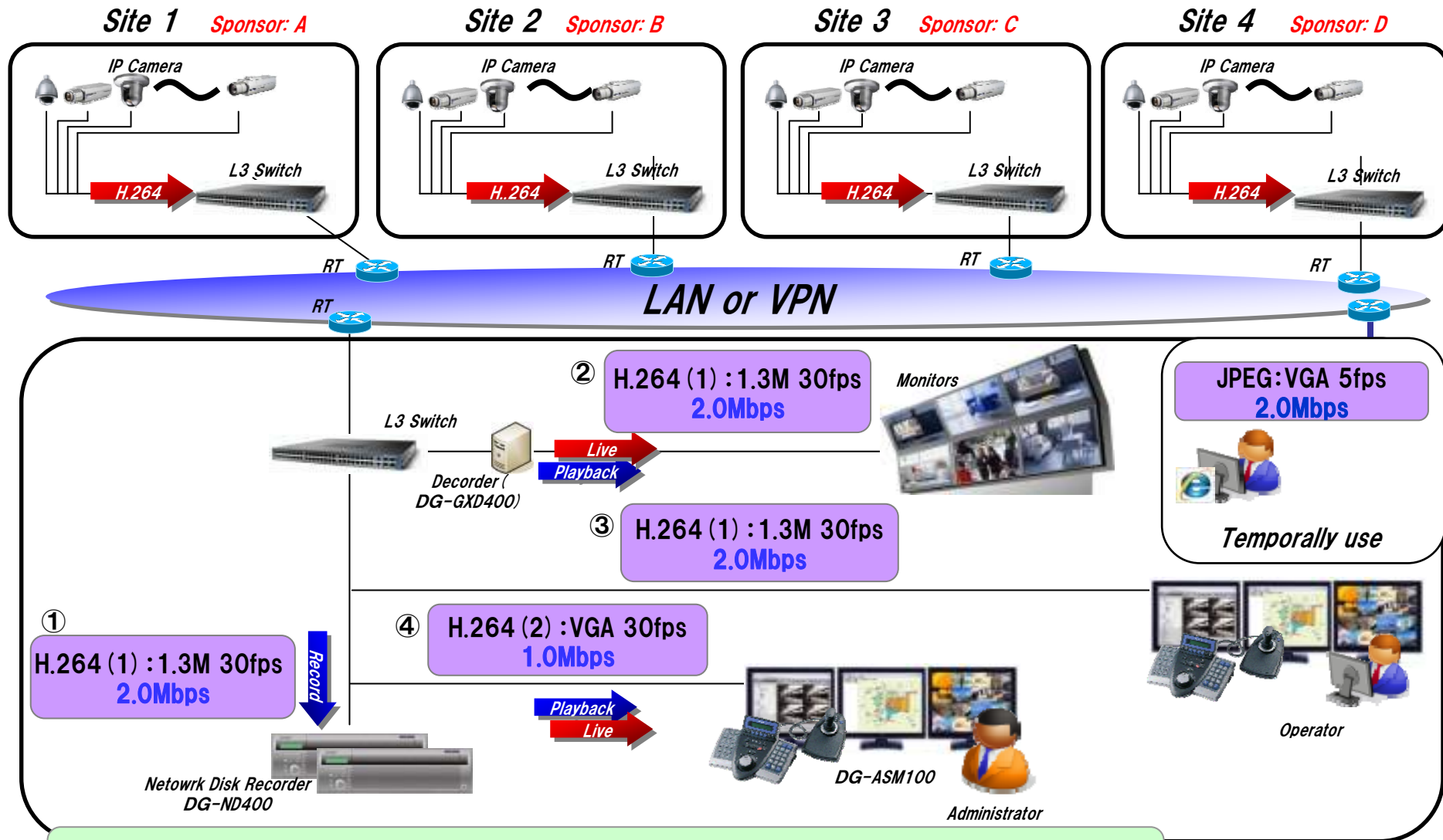













System Example



Total : 7Mbps + 2Mbps = 9Mbps (< 16Mbps:Target max bit rate)

2010 i-pro H.264 Cameras Production

i-PRO
SmartHD

														
NP502	NW502	SC385	SW395	SW355	SP306 SP305	SF336 SF335	SF346	SC384	SP105	SP302	SF332	SF342	SW352	SP102
3.0 Mega		1.3 Mega							SVGA			VGA		
1080P 15fps 1.3M/720P 30fps		1.3M,720P 30fps							30fps			30 fps		
MEGA Super Dynamic					Wide Dynamic Range					Wide Dynamic Range		SD*		
H.264 REC 										H.264 REC 				

* SD: Super dynamic

Panasonic ideas for life

Panasonic
ideas for life