

Panasonic

Installation Guide

Network Camera

Model No. **WV-NP502E**

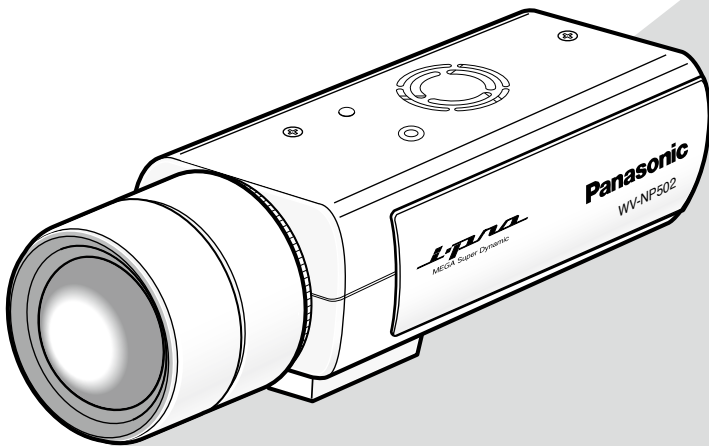

Lens: Option



Before attempting to connect or operate this product, please read these instructions carefully and save this manual for future use.

The model number is abbreviated in some descriptions in this manual.

WARNING:

- Apparatus shall be connected to a mains socket outlet with a protective earthing connection.
- The mains plug or an appliance coupler shall remain readily operable.
- To prevent fire or electric shock hazard, do not expose this apparatus to rain or moisture.
- The apparatus should not be exposed to dripping or splashing and that no objects filled with liquids, such as vases, should be placed on the apparatus.
- All work related to the installation of this product should be made by qualified service personnel or system installers.
- For PERMANENTLY CONNECTED APPARATUS provided neither with an all-pole MAINS SWITCH nor an all-all pole circuit breaker, the installation shall be carried out in accordance with all applicable installation rules.
- The connections should comply with local electrical code.

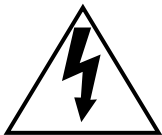

The lightning flash with arrow-head symbol, within an equilateral triangle, is intended to alert the user to the presence of uninsulated "dangerous voltage" within the product's enclosure that may be of sufficient magnitude to constitute a risk of electric shock to persons.



The exclamation point within an equilateral triangle is intended to alert the user to the presence of important operating and maintenance (servicing) instructions in the literature accompanying the appliance.

Power disconnection. Unit with or without ON-OFF switches have power supplied to the unit whenever the power cord is inserted into the power source; however, the unit is operational only when the ON-OFF switch is in the ON position. Unplug the power cord to disconnect the main power for all units.

We declare under our sole responsibility that the product to which this declaration relates is in conformity with the standards or other normative documents following the provisions of Directives 2006/95/EC and 2004/108/EC.

Wir erklären in alleiniger Verantwortung, daß das Produkt, auf das sich diese Erklärung bezieht, mit den folgenden Normen oder normativen Dokumenten übereinstimmt. Gemäß den Bestimmungen der Richtlinie 2006/95/EC und 2004/108/EC.

Nous déclarons sous notre propre responsabilité que le produit auquel se réfère la présente déclaration est conforme aux normes spécifiées ou à tout autre document normatif conformément aux dispositions des directives 2006/95/CE et 2004/108/CE.

Nosotros declaramos bajo nuestra única responsabilidad que el producto a que hace referencia esta declaración está conforme con las normas u otros documentos normativos siguiendo las estipulaciones de las directivas 2006/95/CE y 2004/108/CE.

Noi dichiariamo sotto nostra esclusiva responsabilità che il prodotto a cui si riferisce la presente dichiarazione risulta conforme ai seguenti standard o altri documenti normativi conformi alle disposizioni delle direttive 2006/95/CE e 2004/108/CE.

Wij verklaren als enige aansprakelijke, dat het product waarop deze verklaring betrekking heeft, voldoet aan de volgende normen of andere normatieve documenten, overeenkomstig de bepalingen van Richtlijnen 2006/95/EC en 2004/108/EC.

Vi erklærer os eneansvarlige for, at dette produkt, som denne deklaration omhandler, er i overensstemmelse med standarder eller andre normative dokumenter i følge bestemmelsene i direktivene 2006/95/EC og 2004/108/EC.

Vi deklarerar härmed vårt fulla ansvar för att den produkt till vilken denna deklaration hänvisar är i överensstämmelse med de standarder eller andra normativa dokument som framställs i direktiv nr 2006/95/EC och 2004/108/EC.

Ilmoitamme yksinomaisella vastuullamme, että tuote, jota tämä ilmoitus koskee, noudattaa seuraavia standardeja tai muita ohjeellisia asiakirjoja, jotka noudattavat direktiivien 2006/95/EC ja 2004/108/EC säädköksiä.

Vi erklærer oss alene ansvarlige for at produktet som denne erklæringen gjelder for, er i overensstemmelse med følgende normer eller andre normgivende dokumenter som følger bestemmelsene i direktivene 2006/95/EC og 2004/108/EC.

Contents

Important safety instructions	4
Limitation of liability	5
Disclaimer of warranty	5
Preface	5
Main functions	6
About the user manuals	7
System requirements for a PC	7
Trademarks and registered trademarks	8
About copyright and licence	8
Network security	8
Precautions	9
Precautions for Installation	12
Major operating controls and their functions	14
Lens mounting	15
Insert/remove an SDHC/SD memory card	17
Installation	18
Connection	22
Configure the network settings	26
Troubleshooting	28
Specifications	29
Standard accessories	31

Important safety instructions

- 1) Read these instructions.
- 2) Keep these instructions.
- 3) Heed all warnings.
- 4) Follow all instructions.
- 5) Do not use this apparatus near water.
- 6) Clean only with dry cloth.
- 7) Do not block any ventilation openings. Install in accordance with the manufacturer's instructions.
- 8) Do not install near any heat sources such as radiators, heat registers, stoves, or other apparatus (including amplifiers) that produce heat.
- 9) Do not defeat the safety purpose of the polarized or grounding-type plug. A polarized plug has two blades with one wider than the other. A grounding type plug has two blades and a third grounding prong. The wide blade or the third prong are provided for your safety. If the provided plug does not fit into your outlet, consult an electrician for replacement of the obsolete outlet.
- 10) Protect the power cord from being walked on or pinched particularly at plugs, convenience receptacles, and the point where they exit from the apparatus.
- 11) Only use attachments/accessories specified by the manufacturer.
- 12) Use only with the cart, stand, tripod, bracket, or table specified by the manufacturer, or sold with the apparatus. When a cart is used, use caution when moving the cart/apparatus combination to avoid injury from tip-over.



- 13) Unplug this apparatus during lightning storms or when unused for long periods of time.
- 14) Refer all servicing to qualified service personnel. Servicing is required when the apparatus has been damaged in any way, such as power-supply cord or plug is damaged, liquid has been spilled or objects have fallen into the apparatus, the apparatus has been exposed to rain or moisture, does not operate normally, or has been dropped.

Limitation of liability

THIS PUBLICATION IS PROVIDED "AS IS" WITHOUT WARRANTY OF ANY KIND, EITHER EXPRESS OR IMPLIED, INCLUDING BUT NOT LIMITED TO, THE IMPLIED WARRANTIES OF MERCHANTABILITY, FITNESS FOR ANY PARTICULAR PURPOSE, OR NON-INFRINGEMENT OF THE THIRD PARTY'S RIGHT.

THIS PUBLICATION COULD INCLUDE TECHNICAL INACCURACIES OR TYPOGRAPHICAL ERRORS. CHANGES ARE ADDED TO THE INFORMATION HEREIN, AT ANY TIME, FOR THE IMPROVEMENTS OF THIS PUBLICATION AND/OR THE CORRESPONDING PRODUCT (S).

Disclaimer of warranty

IN NO EVENT SHALL Panasonic Corporation BE LIABLE TO ANY PARTY OR ANY PERSON, EXCEPT FOR REPLACEMENT OR REASONABLE MAINTENANCE OF THE PRODUCT, FOR THE CASES, INCLUDING BUT NOT LIMITED TO BELOW:

- (1) ANY DAMAGE AND LOSS, INCLUDING WITHOUT LIMITATION, DIRECT OR INDIRECT, SPECIAL, CONSEQUENTIAL OR EXEMPLARY, ARISING OUT OF OR RELATING TO THE PRODUCT;
- (2) PERSONAL INJURY OR ANY DAMAGE CAUSED BY INAPPROPRIATE USE OR NEGLIGENT OPERATION OF THE USER;
- (3) UNAUTHORIZED DISASSEMBLE, REPAIR OR MODIFICATION OF THE PRODUCT BY THE USER;
- (4) INCONVENIENCE OR ANY LOSS ARISING WHEN IMAGES ARE NOT DISPLAYED, DUE TO ANY REASON OR CAUSE INCLUDING ANY FAILURE OR PROBLEM OF THE PRODUCT;
- (5) ANY PROBLEM, CONSEQUENTIAL INCONVENIENCE, OR LOSS OR DAMAGE, ARISING OUT OF THE SYSTEM COMBINED BY THE DEVICES OF THIRD PARTY;
- (6) ANY CLAIM OR ACTION FOR DAMAGES, BROUGHT BY ANY PERSON OR ORGANIZATION BEING A PHOTOGENIC SUBJECT, DUE TO VIOLATION OF PRIVACY WITH THE RESULT OF THAT SURVEILLANCE-CAMERA'S PICTURE, INCLUDING SAVED DATA, FOR SOME REASON, BECOMES PUBLIC OR IS USED FOR THE PURPOSE OTHER THAN SURVEILLANCE;
- (7) LOSS OF REGISTERED DATA CAUSED BY ANY FAILURE.

Preface

The network camera WV-NP502 is designed to operate using a PC on a network (10BASE-T/100BASE-TX).

By connecting to a network (LAN) or the Internet, images and audio from the camera can be monitored on a PC via a network.

Note:

- It is necessary to configure the network settings of the PC and its network environment to monitor images from the camera on the PC. It is also necessary to install a web browser on the PC.
-

Main functions

High resolution (2 048 x 1 536) image

Images with high resolution up to 2 048 x 1 536 (3 megapixel) can be transmitted.

MEGA Super Dynamic

Super-Dynamic compensates brightness on a pixel-to-pixel basis resulting in production of natural images even if a subject has various illumination intensities.

H.264/MPEG-4 and JPEG triple encoding

H.264/MPEG-4 dual stream output and JPEG output can be simultaneously provided.

* Either H.264 or MPEG-4 is selectable.

Auto back focus (ABF) function

ABF (Auto Back Focus) ensures easy installation and stable focus in both color and B/W modes.

Black & white function

Images will be displayed clear even at night since the camera will be automatically switched from the color mode to the black and white mode under low illumination condition.

* The operating sound might be heard during the mode change, however it does not indicate any malfunction.

Power over Ethernet function

When connecting with a PoE (Power over Ethernet) device, power will be supplied by simply connecting a LAN cable. (IEEE802.3af compliant)

Interactive communication with audio

By using the audio output connector and the microphone in connector, receiving audio from the camera on a PC and transmitting audio from the PC to the camera is available.

SDHC/SD memory card function

Images can be recorded on an optional SDHC/SD memory card*¹ both automatically (when images fail to transmit using the FTP periodic transmission function) and manually.

The image on the SDHC/SD memory card can be playback on a web browser or downloaded via network.

*¹ Recommended SDHC/SD memory card (☞ page 31)

About the user manuals

There are 2 sets of this manual and the Operating Instructions (PDF).

The "Installation Guide" contains descriptions of how to install and connect this camera, and how perform the required network settings.

Refer to the Operating Instructions (PDF) on the provided CD-ROM for descriptions of how to perform the camera settings and how to operate this camera. Adobe® Reader® is required to read PDF.

System requirements for a PC

CPU:	Intel® Core™ 2 Duo 2.4 GHz or faster recommended
Memory:	512 MB or more (A minimum of 1 GB memory is required when using Microsoft® Windows® 7 or Microsoft® Windows Vista®.)
Network Interface:	10BASE-T/100BASE-TX 1 port
Audio interface:	Sound card (when using the audio function)
Monitor:	Image capture size: 1 024 x 768 pixels or more Color: 24-bit True color or better
OS:	Microsoft® Windows® 7 Professional (64-bit) Microsoft® Windows® 7 Professional (32-bit) Microsoft® Windows Vista® Business SP1 (32-bit) Microsoft® Windows® XP Professional SP3
Web Browser:	Windows® Internet Explorer® 8.0 (Microsoft® Windows® 7 Professional (32-bit/64-bit)) Windows® Internet Explorer® 7.0 (Microsoft® Windows Vista® Business SP1 (32-bit)) Microsoft® Internet Explorer® 6.0 SP3 (Microsoft® Windows® XP Professional SP3)
Other:	CD-ROM drive: It is necessary to read the operating instructions and use the software on the provided CD-ROM. DirectX® 9.0c or later Adobe® Reader®: It is necessary to read the operating instructions on the provided CD-ROM.

Important:

- When using a PC that does not meet the above requirements, displaying of images may become slower or the web browser may become inoperable.
- Audio may not be heard if a sound card is not installed on a PC. Audio may be interrupted depending on the network environment.
- Microsoft® Windows® XP Professional 64-bit Edition is not supported.
- When using IPv6 for communication, use Microsoft® Windows® 7 or Microsoft® Windows Vista®.

Note:

- Refer to "Notes on Windows Vista® / Windows® 7" (PDF) for further information about system requirements for a PC and precautions when using Microsoft® Windows® 7 or Microsoft® Windows Vista®.
-

Trademarks and registered trademarks

- Microsoft, Windows, Windows Vista, Internet Explorer, ActiveX and DirectX are either registered trademarks or trademarks of Microsoft Corporation in the United States and other countries.
- Intel, Pentium and Intel Core are trademarks or registered trademarks of Intel Corporation in the U. S. and other countries.
- Adobe and Reader are either registered trademarks or trademarks of Adobe Systems Incorporated in the United States and/or other countries.
- SDHC logo is a trademark.
- Other names of companies and products contained in these operating instructions may be trademarks or registered trademarks of their respective owners.

About copyright and licence

Distributing, copying, disassembling, reverse compiling, reverse engineering, and also exporting in violation of export laws of the software provided with this unit are expressly prohibited.

Network security

As you will use this unit connected to a network, your attention is called to the following security risks.

- ① Leakage or theft of information through this unit
- ② Use of this unit for illegal operations by persons with malicious intent
- ③ Interference with or stoppage of this unit by persons with malicious intent

It is your responsibility to take precautions such as those described below to protect yourself against the above network security risks.

- Use this unit in a network secured by a firewall, etc.
- If this unit is connected to a network that includes PCs, make sure that the system is not infected by computer viruses or other malicious entities (using a regularly updated anti-virus program, anti-spyware program, etc.).
- Protect your network against unauthorized access by restricting users to those who log in with an authorized user name and password.
- Apply measures such as user authentication to protect your network against leakage or theft of information, including image data, authentication information (user names and passwords), alarm mail information, FTP server information and DDNS server information.
- Do not install the camera in locations where the camera or the cables can be destroyed or damaged by persons with malicious intent.

Precautions

Refer installation work to the dealer.

Installation work requires technique and experiences. Failure to observe this may cause fire, electric shock, injury, or damage to the product.

Be sure to consult the dealer.

Stop the operation immediately when something is wrong with this product.

When smoke goes up from this product or the smell of smoke comes from this product, stop the operation immediately and contact your dealer.

Turn the power off immediately and contact qualified service personnel for service.

Do not attempt to disassemble or modify this product.

Failure to observe this may cause fire or electric shock.

Consult the dealer for the repair or inspections.

Do not insert any foreign objects.

This could permanently damage the apparatus. Turn the power off immediately and contact qualified service personnel for service.

Select an installation area that can support the total weight.

Selecting an inappropriate installation surface may cause the product to fall down or topple over, resulting in injury.

Installation work shall be started after sufficient reinforcement.

Periodic inspections shall be conducted.

Rust on the metal parts or screws may cause a fall of the product resulting in injury.

Consult the dealer for the inspections.

Do not use this product in an inflammable atmosphere.

Failure to observe this may cause an explosion resulting in injury.

Avoid installing this bracket in the locations where salt damage occurs or corrosive gas is produced.

Otherwise, the mounting portions will deteriorate and accidents such as a fall of this product may occur.

The measures of protection against a fall of this product shall be taken.

Failure to observe this may cause a drop resulting in injury.

Be sure to install the safety wire.

The exclusively designed mount bracket shall be used.

Failure to observe this may cause a drop resulting in injury or accidents.

Use the exclusively designed mount bracket for installation.

The screws and bolts shall be tightened to the specified torque.

Failure to observe this may cause a drop resulting in injury or accidents.

Turn the power off when cleaning of this product.

Failure to observe this may cause injury.

[Precautions for use]

This system is designed to be used indoors. This product is not operable outdoors.

To keep on using with stable performance

Do not use this camera in hot and humid conditions for a long time. Failure to observe this causes component degradation resulting in life shortening of this product. (Recommended operating temperature: +35 °C or lower)

Do not expose this camera to direct heat sources such as a heater.

Handle this camera with care.

Do not drop this camera, nor apply shock or vibration to this camera. Failure to observe this may cause trouble.

About the PC monitor

Displaying the same image on a CRT type monitor for a long time may damage the monitor. It is recommended to use a screen-saver.

When an error is detected, this product will restart automatically.

This product will be inoperable for around 2 minutes after the restart just as when the power is turned on.

Product disposal/transfer

Images saved on the SDHC/SD memory card may lead to personal information leakage. When it is necessary to dispose or give this product to someone, even when for repair, make sure that there is no data on the hard disk drives.

Cleaning this product body

Be sure to turn off the power before cleaning. Do not use strong abrasive detergent when cleaning this camera. Otherwise, it may cause discoloration.

When using a chemical cloth for cleaning, read the caution provided with the chemical cloth product.

When the dirt is hard to remove, use a mild detergent and wipe gently.

When the dirt is hard to remove, use a mild detergent and wipe gently. Then, wipe off the remaining detergent with a dry cloth.

Transmission interval

Image transmission interval may become slow depending on the network environment, PC performance, shooting subject, access number, etc.

About SDHC/SD memory card

- Before inserting the SDHC/SD memory card, turn off the power of this product first. Otherwise, it may cause malfunction or damage data recorded on the SDHC/SD memory card. Refer to page 17 for descriptions of how to insert/remove an SDHC/SD memory card.
- When using an unformatted SDHC/SD memory card, format it using this camera. Recorded data on the SDHC/SD memory card will be deleted when formatted. If an unformatted SDHC/SD memory card or an SDHC/SD memory card formatted with other devices is used, this product may not work properly or performance deterioration may be caused. Refer to the Operating Instructions (PDF) for how to format a SDHC/SD memory card.
- If another SDHC/SD memory card is used, this product may not work properly or performance deterioration may be caused.

Code label

The code labels (accessory) are required at inquiry for trouble. Use caution not to lose these labels. It is recommended to paste one of the labels onto the CD-ROM case.

Discoloration on the CCD color filter

When continuously shooting a bright light source such as a spotlight, the color filter of the CCD may have deteriorated and it may cause discoloration. Even when changing the fixed shooting direction after continuously shooting a spotlight for a certain period, the discoloration may remain.

Do not aim the camera at strong light sources.

A light source such as a spot light causes a blooming (light bleeding) or a smear (vertical lines).

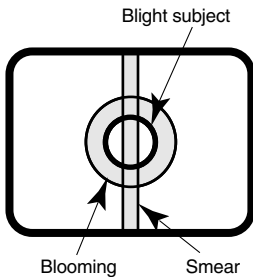

AVC Patent Portfolio License

THIS PRODUCT IS LICENSED UNDER THE AVC PATENT PORTFOLIO LICENSE FOR THE PERSONAL USE OF A CONSUMER OR OTHER USES IN WHICH IT DOES NOT RECEIVE REMUNERATION TO (i) ENCODE VIDEO IN COMPLIANCE WITH THE AVC STANDARD ("AVC VIDEO") AND/OR (ii) DECODE AVC VIDEO THAT WAS ENCODED BY A CONSUMER ENGAGED IN A PERSONAL ACTIVITY AND/OR WAS OBTAINED FROM A VIDEO PROVIDER LICENSED TO PROVIDE AVC VIDEO. NO LICENSE IS GRANTED OR SHALL BE IMPLIED FOR ANY OTHER USE. ADDITIONAL INFORMATION MAY BE OBTAINED FROM MPEG LA, L.L.C. SEE [HTTP://WWW.MPEGLA.COM](http://www.mpegla.com)

MPEG-4 Visual Patent Portfolio License

This product is licensed under the MPEG-4 Visual Patent Portfolio License for the personal and non-commercial use of a consumer for (i) encoding video in compliance with the MPEG-4 Visual Standard ("MPEG-4 Video") and/or (ii) decoding MPEG-4 Video that was encoded by a consumer engaged in a personal and non-commercial activity and/or was obtained from a video provider licensed by MPEG LA to provide MPEG-4 Video. No license is granted or shall be implied for any other use. Additional information including that relating to promotional, internal and commercial uses and licensing may be obtained from MPEG LA, LLC. See <http://www.mpegla.com>.

Precautions for Installation

This camera is designed to be used indoors.

This camera is not operable outdoors. Do not expose this camera to direct sunlight for hours and do not install the product near a heater or an air conditioner. Otherwise, it may cause deformation, discoloration and malfunction. Keep this camera away from water and moisture.

Installation place

Do not place the unit in the following places:

- Locations where it may get wet from rain or water splash
- Locations where a chemical agent is used such as a swimming pool
- Locations subject to humidity, dust, steam and oil smoke
- Locations in a specific environment where a solvent or a flammable atmosphere exists
- Locations where a radiation, an X-ray, a strong radio wave or a strong magnetic field is generated
- Locations where corrosive gas is produced, Locations where it may be damaged by briny air such as seashores
- Locations where the temperature is not within $-10\text{ }^{\circ}\text{C}$ to $+50\text{ }^{\circ}\text{C}$.
- Locations subject to vibrations (This product is not designed for on-vehicle use.)
- Locations subject to condensation as the result of severe changes in temperature

Be sure to remove this product if it is not in use.

Shielded (STP) network cables must be used with this unit to ensure compliance with EMC standards.

Before installation

- The camera mount bracket described on page 20 shall be used to mount the camera.
- When this camera and camera mount bracket are mounted on a ceiling or a wall, use the screws described on page 20. The screws to be used are not provided. Prepare the screws according to the material, structure, strength and other factors of the mounting area and the total weight of objects to be mounted.
- Ensure that the mounting surface, anchor and screws are sufficiently strong.
- Do not mount this product on a plaster board or a wooden section because they are too weak. If this product is unavoidably mounted on such a section, the section shall be sufficiently reinforced.

Prepare them according to the material and strength of the area where this product is to be installed.

- The screws must be tightened with an appropriate tightening torque according to the material and strength of the installation area.
- Do not use an impact driver. Use of an impact driver may damage the screws.
- When a screw is tightened, make the screw at a right angle to the surface. After tightening the screws or bolts, perform visual check to ensure tightening is enough and there is no backlash.

Fall prevention measures

When the external safety wire is connected, select a connection point resulting in that nothing will hit people after the mount bracket is damaged. The wire length shall be adjusted to remove slack.

Angle adjustment

Be sure to loosen the screw of this product mount bracket when the camera angle is adjusted. If the camera angle is changed when the screw is tight, excessive force is applied to the camera mount bracket and camera, and accordingly they may be damaged. Be sure to tighten the screw securely after camera angle adjustment.

Radio disturbance

When this product is used near TV/radio antenna, strong electric field or magnetic field (near a motor, a transformer or a power line), images may be distorted and noise sound may be produced.

PoE (Power over Ethernet)

Use a PoE hub/device that is compliant with IEEE802.3af standard.

Router

When connecting this product to the Internet, use a broadband router with the port forwarding function (NAT, IP masquerade). Refer to the Operating Instructions (PDF) for further information about the port forwarding function.

Heat dissipation

This camera is designed to dissipate heat inside this product by intaking air from the intake port on the rear to the exhaust port on the top. Therefore, do not block those ports. Approximately 5 cm of clearance from the intake port and exhaust port to a wall shall be left.

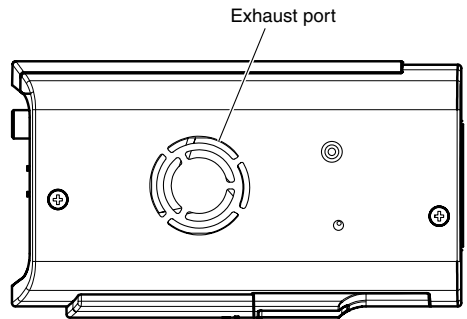
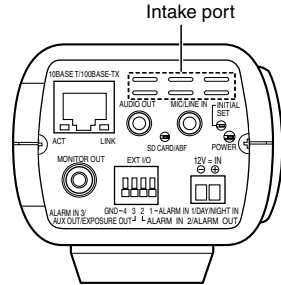

Time & date setting

It is necessary to set the time and date before putting this product into operation. Refer to the Operating Instructions (PDF) on the provided CD-ROM for further information about the setting.

Major operating controls and their functions

<Side view>

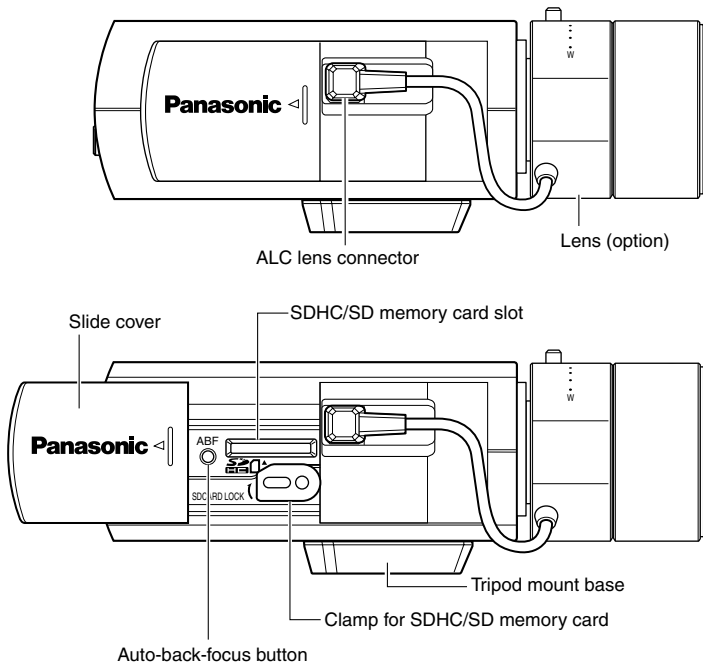

<Rear view>

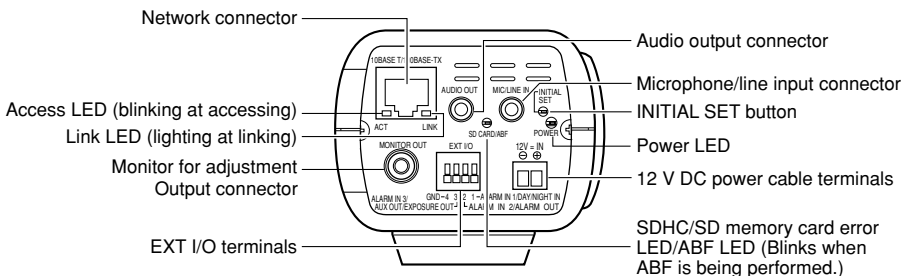

About the [INITIAL SET] button

After turning off the power of the camera, turn on the power of the camera while holding down this button, and wait for around 5 seconds or more without releasing this button. Wait around 2 minutes after releasing the button. The camera will start up and the settings including the network settings will be initialized. Before initializing the settings, it is recommended to write down the settings in advance.

Lens mounting

Slowly rotate the lens clockwise to mount the lens and connect the lens cable to the ALC lens connector of the camera.

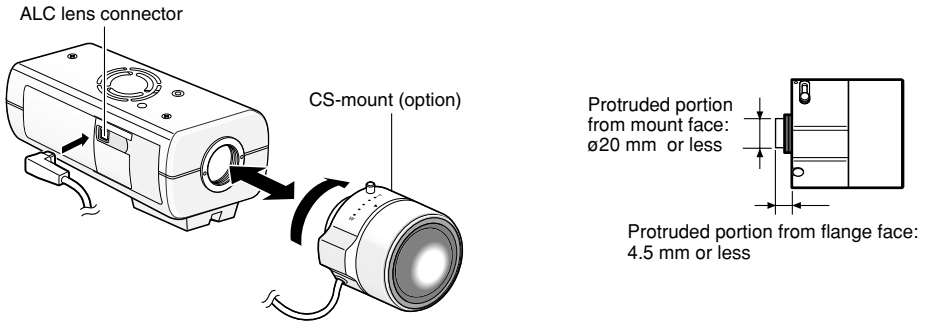

Optional dedicated lens

Product name	Model number
ALC lens for 1/3 type CCD cameras 2x vari-focal (High resolution)	WV-LZA62/2

* If a lens for 1/3 type CCD camera other than the above is mounted and the image capture size is set to "1280x720" or higher, the camera cannot achieve high resolution performance.

How to adjust the focus

- 1 Before adjustment, reset the back focus position by holding down the auto back focus button for 5 seconds or more when the power is on. (This operation can also be performed on the setup menu. Refer to the Operating Instructions (PDF).)
- 2 Adjust the view angle and focus coarsely by adjusting the zoom and focus of the lens to center a subject in the screen, and then press the auto back focus button on the side of the camera (page 14) or perform the auto back focus function from the setup menu. Refer to the Operating Instructions (PDF) for how to perform the auto back focus function from the setup menu.

Note:

- The most common use of a varifocal lens and a zoom lens
Note that the adjustment method is different depending on the type. For further information, refer to the operating instructions for the lens to be used.
When using 8x or 10x lens, adjust the back focus after positioning the zoom ring at the "W" end and positioning the focus ring at a step short of the "F" end.
When using 2x or 3x lens, adjust the back focus after positioning the zoom ring at the "T" end and positioning the focus ring at a step short of the "F" end.
 - Depending on the lens to be used, if the zoom ring is fully rotated in the "W" direction, the periphery may become dark. In such a case, rotate the zoom ring in the "T" direction for readjustment.
 - When images in the near-infrared light area change from the color mode to the black & white mode, out-of-focus may be occurred according to the nature of optical property. In this case, the focus can be corrected by selecting "Auto" or "Preset" for "Adjusting method" on the setup menu (The focus will not automatically be adjusted according to the illumination level change once the focus is corrected.) Refer to the Operating Instructions (PDF) for how to configure the "Adjusting method" setting on the setup menu.
 - When shooting the following subjects, it may have difficulty adjusting the back focus position automatically.
In this case, adjust the back focus position manually from the setup menu.
Refer to the Operating Instructions (PDF) for how to perform the auto back focus function from the setup menu.
 - Subj. moves frequently
 - Subj. with large illuminance change
 - Subj. with low illuminance
 - Subj. through a window
 - Subj. with less contrast such as white wall
 - Subj. with heavy flicker
-

Insert/remove an SDHC/SD memory card

Important:

- Before inserting a SDHC/SD memory card, turn off the power of the camera first.
- Insert the SDHC/SD memory card backside up.
- Before removing the SDHC/SD memory card, select "Not use" for "About SD memory card" on the [SD memory card] tab of "Basic" on the setup menu first. Turn off the power after "Not use" selection, and then unload the SDHC/SD memory card. (☞ Operating Instructions)

- 1 Open the slide cover on the side of the camera, and then insert a SDHC/SD memory card into the SDHC/SD memory card slot.

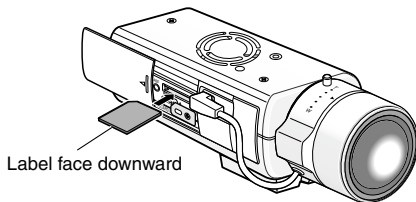

- 2 If necessary, loosen the screw of the clamp for SDHC/SD memory card and tighten the screw after rotating the clamp 90° clockwise. (Recommended tightening torque: 0.19 N·m)

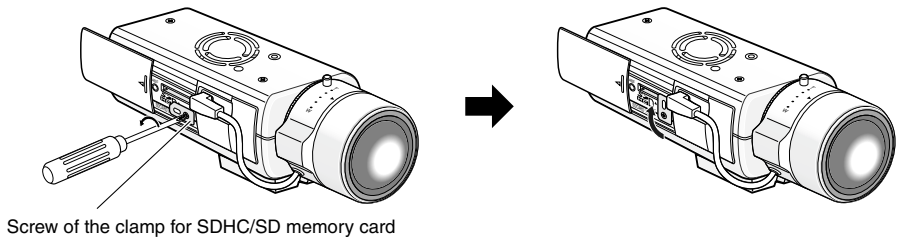

- 3 Close the slide cover on the side of the camera.
- 4 To remove the SDHC/SD memory card, rotate the clamp for SDHC/SD memory card 90 degrees counterclockwise, push the memory card to unlock it, and remove the memory card from the SDHC/SD memory card slot.

Installation

Connect the safety wire

The following is an example of safety wire connection. A safety wire kit shall be procured in accordance with the mounting face of the camera.

Refer also to the instructions for the safety wire kit at mounting the safety wire.

Important:

- Be sure to install the safety wire. Ask your dealer for installation.
-

For mounting on ceiling

<Required camera mount bracket and safety wire kit>

- Camera mounting plate: WV-7010A
- Safety wire kit: WV-Q141

- 1** Remove the tripod mount base on the top of the camera.
- 2** Align the tripod mount base with the safety wire plate for ceiling (accessory) and attach them to the camera with the mounting screws.

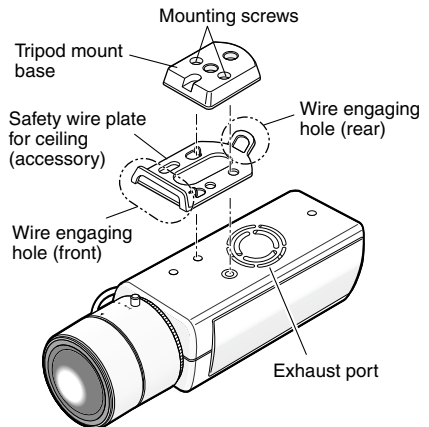

Important:

- Use the detached mounting screws to attach the tripod mount base. When using different length screws, it may damage the camera or cause the camera to fall. (Recommended tightening torque: 0.39 N·m)
-

- 3** Engage the safety wires (2 pieces) with the wire engaging holes (front and rear) respectively.

Wire engaging hole

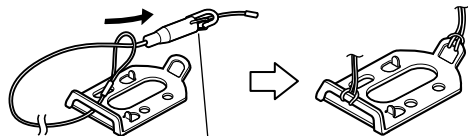

Connection hook

- ①** Pass the ring part of the safety wire through the wire engaging hole.
- ②** Pass the connection hook through the ring part of the safety wire.

Important:

- Use caution to prevent the safety wire from entering into the exhaust port.
-

For mounting on wall

<Required camera mount bracket and safety wire kit>

- Camera mounting plate: WV-831
- Safety wire kit: WV-Q140

1 Put the tripod mount base on the bottom of the camera.

Secure the safety wire lug for wall (accessory) to the camera mount screw hole with the fixing screw (accessory).

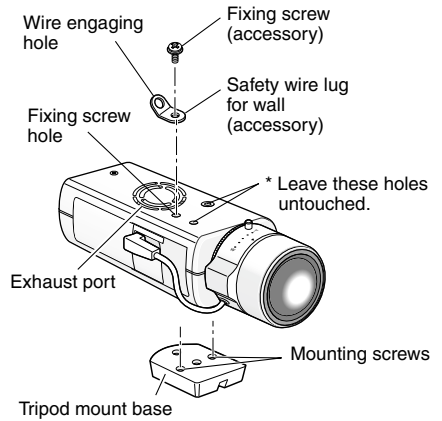

Important:

- Be sure to use the provided fixing screws and the removed screws to attach the tripod mount base.

When using different length screws, it may damage the camera or cause the camera to fall.

(Recommended tightening torque:
0.39 N·m)

2 Engage the safety wire with the wire engaging hole.

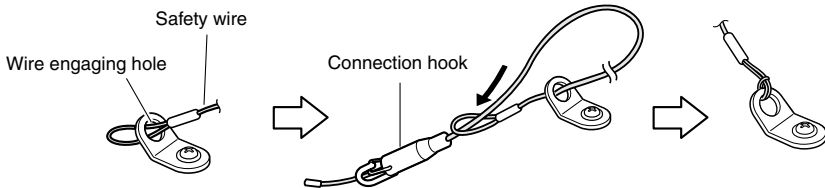

① Pass the ring part of the safety wire through the wire engaging hole.

② Pass the connection hook through the ring part of the safety wire.

Important:

- Use caution to prevent the safety wire from entering into the exhaust port.
-

Camera mounting

The camera is mounted on the camera mount bracket (option) and the safety wire is secured.

Important:

- The installation area shall be strong enough to hold the camera and camera mount bracket (option).
 - The camera mount bracket (option) shall be mounted on the foundation part of the construction or a part with adequate strength.
 - To prevent the mounting strength from becoming lower, do not use wooden screws to secure the camera mount bracket (option).
-

1 Secure the camera mount bracket (option) to an installation position, and mount the camera on the camera mount bracket.

Prepare mounting screws according to the material of the area where the camera mount bracket (option) is to be installed. The installation method may be different depending on the material of the area where the bracket is to be installed.

- When installing on steel: Fix with bolts and nuts (M6 or M8)
- When installing on concrete: Fix with anchor bolts (M6 or M8)

The mounting conditions of the camera mount bracket are described as follows:

Installation position	Applicable mount bracket	Recommended screw	Screw quantity	Minimum pull-out strength (per 1 pc.)
On ceiling	WV-7010A	M6 or M8	3 pieces	196 N
On wall	WV-831	M8	4 pieces	921 N

Important:

- When the camera mount bracket is mounted on a wall, be sure to observe the mounting height described on the illustration.

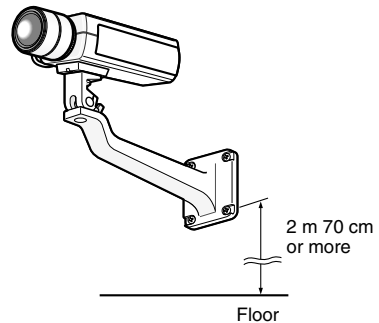

- 2** Put the connection hook of the safety wire on the safety wire plate (included in the safety wire kit) or the safety wire lug (included in the safety wire kit) secured on the foundation part of the construction or a part with adequate strength.

Important:

- The safety wire shall be adjusted to remove slack.

<For mounting on ceiling>

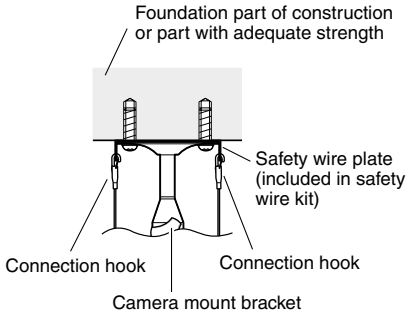

<Mounting sample>

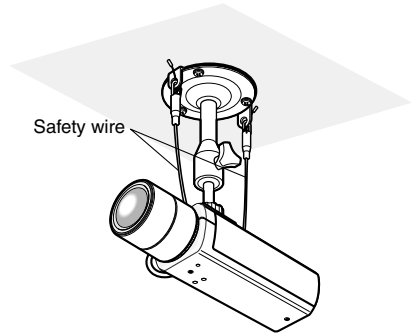

<For mounting on wall>

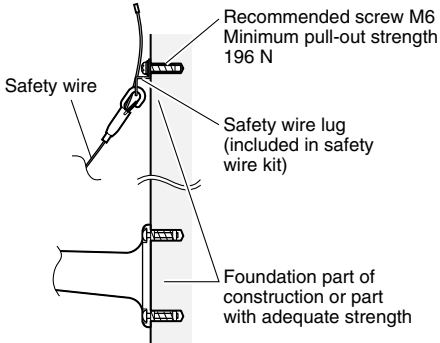

<Mounting sample>

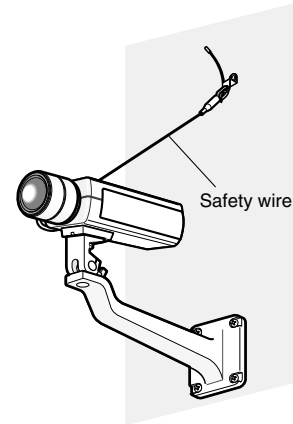

Connection

Caution:

- ONLY CONNECT WV-NP502 TO 12 V DC CLASS 2 POWER SUPPLY.

Before starting the connection, turn off the power of this camera and the devices to be connected. Before start the connection, prepare the required devices and cables.

- 1 Connect the RCA jack to the monitor output connector for adjustment on the rear (only for adjustment of the angle field of view).

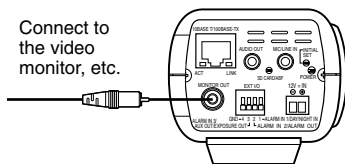

Important:

- The monitor output connector is provided only for checking the adjustment the angle field of view on the video monitor when installing the camera or when servicing. It is not provided for recording/ monitoring use.
- When "3 mega pixel" is selected for "Imaging mode", black bands may appear at the top, bottom, right and left of the screen. (There is no problem with adjustment since the angle field of view is not affected.)
- When the image capture mode is changed, the images displayed on the video monitor may sometimes be distorted until the camera is restarted.

- 2 Connect the microphone to MIC/LINE IN (for use of the audio reception function).

Input impedance: Approx. 2 k Ω

Recommended cable length: 1 m or less (for microphone input)
10 m or less (for LINE input)

Recommended microphone: Plug-in power type microphone (option)
Connect a monaural mini plug (ϕ 3.5 mm).

- Supply voltage: 2.5 V \pm 0.5 V
- Recommended sensitivity of microphone: -48 dB \pm 3 dB (0 dB=1 V/Pa, 1 kHz)

Important:

- Connect/disconnect the audio cables and turn on the power of the camera after turning off the power of the audio output devices. Otherwise, loud noise may be heard from the speaker.

- 3 Connect an external speaker with amplifier to the audio output connector (for use of the audio transmission function).

Connect a monaural mini plug (ϕ 3.5 mm).

- Recommended cable length: 10 m or less

- 4** Connect external devices to the EXT I/O terminal.
When connecting an external device, remove 9 mm - 10 mm of the outer jacket of the cable and twist the cable core to prevent the short circuit first.

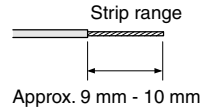

Specification of cable (wire): 22 AWG - 28 AWG

Single core, twisted

- * Check whether the stripped part of the wire is not exposed and is securely connected.

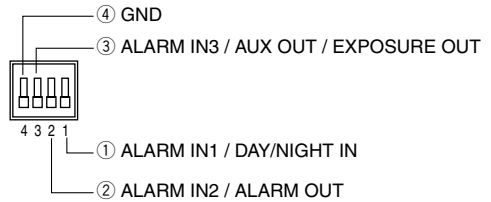

Important:

- Do not connect 2 wires or more directly to a terminal. When it is necessary to connect 2 or more wires, use a splitter.
- Connect an external device with verifying that the ratings are within the specifications above.
- When using the EXT I/O terminals as the output terminals, ensure they do not cause signal collision with external signals.

<Ratings>

- ALARM OUT
AUX OUT/EXPOSURE OUT

Output specification: Open collector output (maximum applied voltage: 20 V DC)

Open: 4 - 5 V DC by internal pull-up

Close: Output voltage 1 V DC or less (50 mA or less)

- ALARM IN1 / DAY/NIGHT IN
ALARM IN2
ALARM IN3

Input specification: No-voltage make contact input (4 - 5 V DC, internally pulled up)

OFF: Open or 4 - 5 V DC

ON: Make contact with GND (required drive current: 1 mA or more)

- 5** Connect a LAN cable (category 5 or better) to the network connector on the rear of the camera.

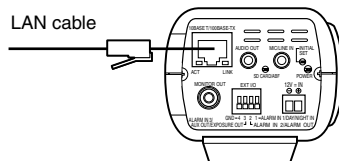

- 6** Connect the power cord.

Important:

- The 12 V DC power supply shall be insulated from 120 V AC.

When using 12 V DC power supply

- ① Loosen the screw of the power cord plug (accessory).
- ② Connect the cable of the 12 V DC power supply to the power cord plug.

Strip 3 mm - 7 mm from the end of the wire, and twist the stripped part of the wire sufficiently to avoid short circuit.

Specification of cable (wire): 16 AWG - 28 AWG,
Single core, twisted

- Check whether the stripped part of the wire is not exposed and is securely connected.
- ③ Tighten the screw of the power cord plug.
 - ④ Connect the power cord plug to the 12 V DC power supply terminal on the rear of the camera.

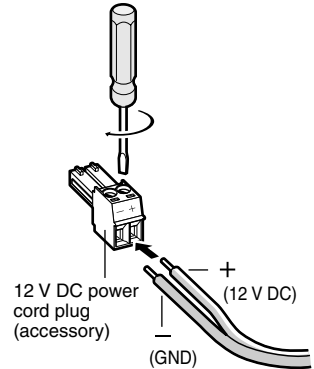
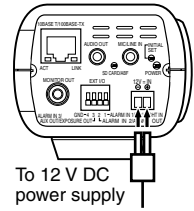

Important:

- Be sure to fully insert the power cord plug (accessory) into the 12 V DC power supply terminal. Otherwise, it may damage the camera or cause malfunction.
-

When using PoE (IEEE802.3af compliant)

Connect an Ethernet cable (category 5 or better) between a PoE device (such as a hub) and the network connector of the camera.

Important:

- Use all 4 pairs (8 pins) of the LAN cable.
 - The maximum cable length is 100 m.
 - Make sure that the PoE device in use is compliant with IEEE802.3af standard.
 - When connecting both the 12 V DC power supply and the PoE device for power supply, PoE will be used for power supply.
 - When disconnecting the LAN cable once, reconnect the cable after about 2 seconds. When the cable is quickly connected, the power may not be supplied from the PoE device.
-

Connection example when connecting to a network using a PoE hub

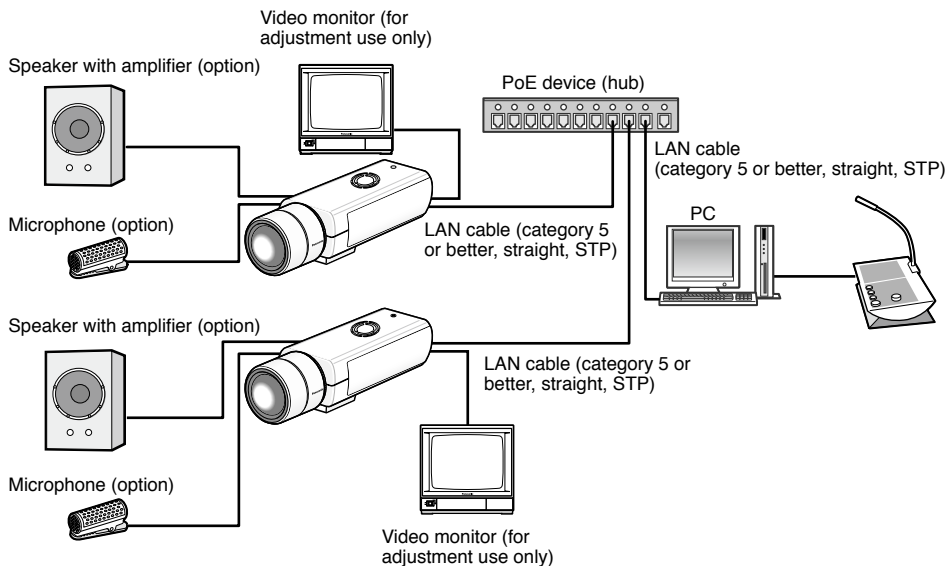

<Required cable>

LAN cable (category 5 or better, straight, STP)

Important:

- The video monitor is used for checking the adjustment of the angular field of view when installing the camera or when servicing. It is not provided for recording/ monitoring use.
 - Use a switching hub or a router which is compliant with 10BASE-T/100BASE-TX.
 - Power supply is required for each network camera. When using a PoE device (hub), 12 V DC power supply is unnecessary.
-

Configure the network settings

Install the software

Before installing the software, read the readme file on the provided CD-ROM first.

Software included on the provided CD-ROM

- Panasonic IP setting software
Configure the network settings of the camera. Refer to the following for further information.
- Viewer Software "Network Camera View4"
It is necessary to install the viewer software "Network Camera View4" to display images on a PC. Install the viewer software by double-clicking the "nwc4setup.exe" icon on the provided CD-ROM.

Configure the network settings of the camera using the Panasonic IP setting software

It is possible to configure the network settings of the camera using the IP setup software on the provided CD-ROM.

When using multiple cameras, it is necessary to configure the network settings of each camera independently.

If the Panasonic IP setting software does not work, configure the network settings of the camera and the PC individually on the "Network" page of the setup menu. Refer to the Operating Instructions (PDF) for further information.

Important:

- When using Microsoft® Windows Vista®, the "Windows Security Alert" window may be displayed when starting the IP setup software. In this case, disable "User Account Control" from the control panel.
 - For the security enhancement, the MAC address/IP address of the camera to be configured will not be displayed when around 20 minutes have passed after turning on the power of the camera. (when the effective period is set to "20min only" in the Easy IP setup)
 - Panasonic IP setting software is inoperable in other subnets via the same router.
 - This camera cannot be displayed or set with an older version of the IP setup software (version 2.xx).
-

- 1 Start the Panasonic IP setting software.
- 2 Click the [IP setting] button after selecting the MAC address/IP address of the camera to be configured.

Note:

- When using a DHCP server, the IP address assigned to the camera can be displayed by clicking the [Refresh] button of the IP setting software.
- When a duplicate IP address is used, the corresponding MAC address/IP address will be displayed shaded.

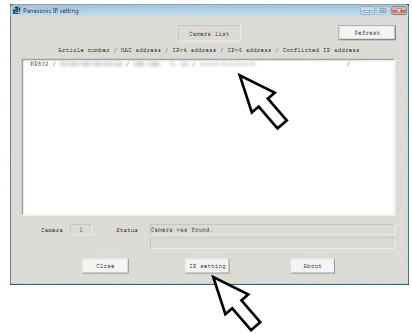

- 3 Complete each network setup item and click the [Apply] button.

Note:

- When using a DHCP server, it is possible to set "DNS" to "AUTO".

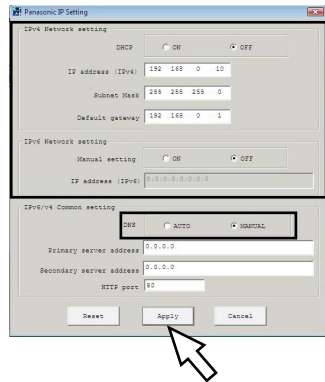

Important:

- It may take for around 2 minutes to complete to upload the settings to the camera after clicking the [Apply] button. The settings may be invalidated when the 12 V DC power supply is cut or when the LAN cable is disconnected before completing the upload. In this case, perform the settings again.
- When using a firewall (including software), allow access to all UDP ports.

Troubleshooting

Before asking for repairs, check the symptoms with the following table.

Contact your dealer if a problem cannot be solved even after checking and trying the solution in the table or a problem is not described below.

Symptom	Cause/solution	Reference pages
<p>Power is not turned on.</p>	<p>When using DC power supply</p> <ul style="list-style-type: none">• Is 12 V DC power supply connected to the power supply terminal? → Check whether the connection is appropriately established. <p>When using a PoE device for power supply</p> <ul style="list-style-type: none">• Are the PoE device and the network connector on the rear of the camera connected using a LAN cable (4-pair)? → Check whether the connection is appropriately established.• Depending on the PoE device, the power supply will stop when the demanded power exceeds its total power limit for all PoE ports. → Refer to the operating instructions of the PoE device in use.	<p>23 - 24</p>

Specifications

● Basic

Power source:	12 V DC, PoE (IEEE802.3af compliant)
Power consumption:	12 V DC: 630 mA, PoE: 7.6 W (Class 0 device)
Ambient operating temperature:	-10 °C to +50 °C
Ambient operating humidity:	Less than 90 %
Monitor output (for adjusting the angular field of view):	VBS: 1.0 V [p-p]/75 Ω, composite signal, RCA jack
EXT I/O terminals:	ALARM IN 1 / DAY/NIGHT IN ALARM IN 2 / ALARM OUT ALARM IN 3 / AUX OUT / EXPOSURE OUT x1 each
Microphone/Line input:	ø3.5 mm monaural mini jack
For microphone input:	Input impedance: Approx. 2 kΩ Applicable microphone: Plug-in power type Supply voltage: 2.5 V ±0.5 V
For line input:	Input level: Approx. -10 dBV
Audio output:	ø3.5 mm stereo mini jack (monaural output) Output impedance: Approx. 600 Ω Line level
Dimensions:	75 mm (W) x 65 mm (H) x 132.5 mm (D) (excluding connectors/terminals)
Mass:	Approx. 430 g
Finish:	Fine silver (501)

● Camera

Image sensor:	1/3 type interline transfer CCD
Effective pixels:	1 296 (H) x 976 (V) x 2
Scanning area:	4.86 mm (H) x 3.65 mm (V)
Scanning system:	Progressive
Minimum illumination:	1.3 megapixel mode Color: 1.0 lx, BW: 0.08 lx (F1.4, Auto slow shutter: Off (1/30 s), AGC: High, Super-Dynamic: Off) Color: 0.06 lx, BW: 0.005 lx * Converted value (F1.4, Auto slow shutter: Max. 16/30 s, AGC: High, Super-Dynamic: Off)
Super-Dynamic:	3 megapixel mode Color: 2.0 lx, BW: 0.16 lx (F1.4, Auto slow shutter: Off (1/30 s), AGC: High) Color: 0.12 lx, BW: 0.01 lx * Converted value (F1.4, Auto slow shutter: Max. 16/30 s, AGC: High)
Dynamic range:	On/Off (only at 1.3 megapixel mode) 52 dB typ. (Super-Dynamic: On, Light control: Indoor scene)
Gain (AGC):	On(Low)/ On(Mid)/ On(High)/ Off
Adaptive black stretch:	On/Off (only at Super-Dynamic: Off)
Light control mode setting:	Indoor scene/ Outdoor scene/ ELC (ELC: only at Super-Dynamic: Off)
Shutter speed:	Off(1/30), 3/100, 2/100, 1/100, 1/250, 1/500, 1/1000, 1/2000, 1/4000, 1/10000 (only at Super-Dynamic Off)
Auto slow shutter:	Off, Max. 2/30 s, Max. 4/30 s, Max. 6/30 s, Max. 10/30 s, Max. 16/30 s
Black & white mode:	On/ Off/ AUTO1 (Normal)/ AUTO2 (IR Light)/ AUTO3 (SCC)

White balance:	ATW1/ ATW2/ AWC
Digital noise reduction:	High/Low
Image stabilizer:	On/Off
Video analytics	
Face detection:	On/Off (with the XML notification setting)
Privacy zone:	On/Off (up to 8 zones available)
Camera title on screen:	Up to 16 characters (alphanumeric characters, marks) On/Off
VMD alarm:	On/Off, 4 areas available
Auto back focus:	AUTO/ PRESET/ FIX
ALC lens drive:	DC drive
Lens mount:	CS-mount

● Network

Network:	10BASE-T/100BASE-TX, RJ45 connector
Resolution:	1.3 megapixel mode
	H.264 [4:3]: 1280 x 960/ SVGA (800 x 600)/ VGA (640 x 480)/ QVGA (320 x 240), max. 30 fps
	[16:9]: 1280 x 720/ 640 x 360/ 320 x 180, max. 30 fps
	MPEG-4 [4:3]: VGA (640 x 480)/QVGA (320 x 240), max. 30 fps
	JPEG [4:3]: 1280 x 960/ SVGA (800 x 600)/ VGA (640 x 480)/ QVGA(320 x 240), max. 30 fps
	[16:9]: 1280 x 720/ 640 x 360/ 320 x 180, max. 30 fps
	3 megapixel mode
	H.264 [4:3]: 1280 x 960/ VGA (640 x 480)/ QVGA (320 x 240), max. 15 fps
	[16:9]: 1920 x 1080/ 640 x 360/ 320 x 240, max. 15 fps
	MPEG-4 [4:3]: VGA (640 x 480)/QVGA (320 x 240), max. 15 fps
	JPEG [4:3]: 2048 x 1536/ 1280 x 960/ VGA (640 x 480), max. 15 fps
	[16:9]: 1920 x 1080/ 640 x 360/ 320 x 180, max. 15 fps
Image compression method *1 *2	H.264/MPEG4 Image quality: Low/ Normal/ Fine Transmission type: Unicast/Multicast Video bit rate: Constant bit rate: 64 kbps/ 128 kbps/ 256 kbps/ 384 kbps/ 512 kbps/ 768k bps/ 1024 kbps/ 1536k bps/ 2048 kbps/ 3072 kbps/ 4096 kbps/ *8192 kbps/ Unlimited * only in H.264 mode Frame rate priority: 1 fps/ 3 fps/ 5 fps/ 7.5 fps/ 10 fps/ 12 fps/ 15 fps/ *20 fps/ *30 fps * only in 1.3 megapixel mode
	JPEG Image quality: 0 SUPER FINE/ 1 FINE/ 2/ 3/ 4/ 5 NORMAL/ 6/ 7/ 8/ 9 LOW (10 steps: 0-9) Transmission type: PULL/PUSH
Transmission interval:	0.1 fps - 30 fps (JPEG frame rate will be restricted when displaying both JPEG and H.264/MPEG-4 images.)
Audio compression method:	G.726 (ADPCM) 32 kbps/16 kbps

Bandwidth control:	Unlimited/ 64 kbps/ 128 kbps/ 256 kbps/ 384 kbps/ 512 kbps/ 768 kbps/ 1024 kbps/ 2048 kbps/ 4096 kbps/ 8192 kbps
Protocol:	IPv6: TCP/IP, UDP/IP, HTTP, RTP, FTP, SMTP, DNS, NTP, SNMP IPv4: TCP/IP, UDP/IP, HTTP, RTSP, RTP, RTP/RTCP, FTP, SMTP, DHCP, DNS, DDNS, NTP, SNMP
OS*3, *4:	Microsoft® Windows® 7 Professional (64-bit) Microsoft® Windows® 7 Professional (32-bit) Microsoft® Windows Vista® Business SP1 (32-bit) Microsoft® Windows® XP Professional SP3
Browser:	Windows® Internet Explorer® 8.0 (Microsoft® Windows® 7 Professional (32-bit/64-bit)) Windows® Internet Explorer® 7.0 (Microsoft® Windows Vista® Business SP1 (32-bit)) Microsoft® Internet Explorer® 6.0 SP3 (Microsoft® Windows® XP Professional SP3)
Maximum concurrent access number:	14 (Depends on network conditions)
FTP client:	Alarm image transmission, FTP periodic transmission (When the FTP transmission is failed, backup on an optional SDHC/SD memory card is available.)
Multi-screen:	Up to 16 camera images can be displayed simultaneously on a multi-screen.
Compatible SDHC/SD memory card (option):	Manufactured by Panasonic SDHC memory card: 4 GB, 8 GB, 16 GB, 32 GB SD memory card: 64 MB, 128 MB, 256 MB, 512 MB, 1 GB, 2 GB (except miniSD card and microSD card)

*1 Either H.264 or MPEG-4 is selectable.

*2 Transmission for 2 streams can be individually set in the same compression method.

*3 Refer to "Notes on Windows Vista® / Windows® 7" (PDF) for further information about system requirements for a PC and precautions when using Microsoft® Windows® 7 or Microsoft® Windows Vista®.

*4 When using IPv6 for communication, use Microsoft® Windows® 7 or Microsoft® Windows Vista®.

Standard accessories

Installation Guide (this book)	1 volume
CD-ROM*1	1 pc
Code label*2	1 pc

The following parts are used during installation procedures.

Power cord plug	1 pc.
Safety wire plate for ceiling	1 pc.
Safety wire lug for wall	1 pc.
Screws for mounting bracket (M2.5 x 8 mm)	2 pieces (of them, 1 for spare)

*1 The CD-ROM contains the operating instructions (PDFs) and the software.

*2 This label may be required for network management. The network administrator shall retain the code label.

Information for Users on Collection and Disposal of Old Equipment and used Batteries



These symbols on the products, packaging, and/or accompanying documents mean that used electrical and electronic products and batteries should not be mixed with general household waste.

For proper treatment, recovery and recycling of old products and used batteries, please take them to applicable collection points, in accordance with your national legislation and the Directives 2002/96/EC and 2006/66/EC.

By disposing of these products and batteries correctly, you will help to save valuable resources and prevent any potential negative effects on human health and the environment which could otherwise arise from inappropriate waste handling.

For more information about collection and recycling of old products and batteries, please contact your local municipality, your waste disposal service or the point of sale where you purchased the items.

Penalties may be applicable for incorrect disposal of this waste, in accordance with national legislation.



For business users in the European Union

If you wish to discard electrical and electronic equipment, please contact your dealer or supplier for further information.

[Information on Disposal in other Countries outside the European Union]

These symbols are only valid in the European Union. If you wish to discard these items, please contact your local authorities or dealer and ask for the correct method of disposal.



Cd

Note for the battery symbol (bottom two symbol examples):

This symbol might be used in combination with a chemical symbol. In this case it complies with the requirement set by the Directive for the chemical involved.

Panasonic Corporation

<http://panasonic.net>

Importer's name and address to follow EU rules:

Panasonic Testing Centre
Panasonic Marketing Europe GmbH
Winsbergiring 15, 22525 Hamburg F.R.Germany

© Panasonic System Networks Co., Ltd. 2010