

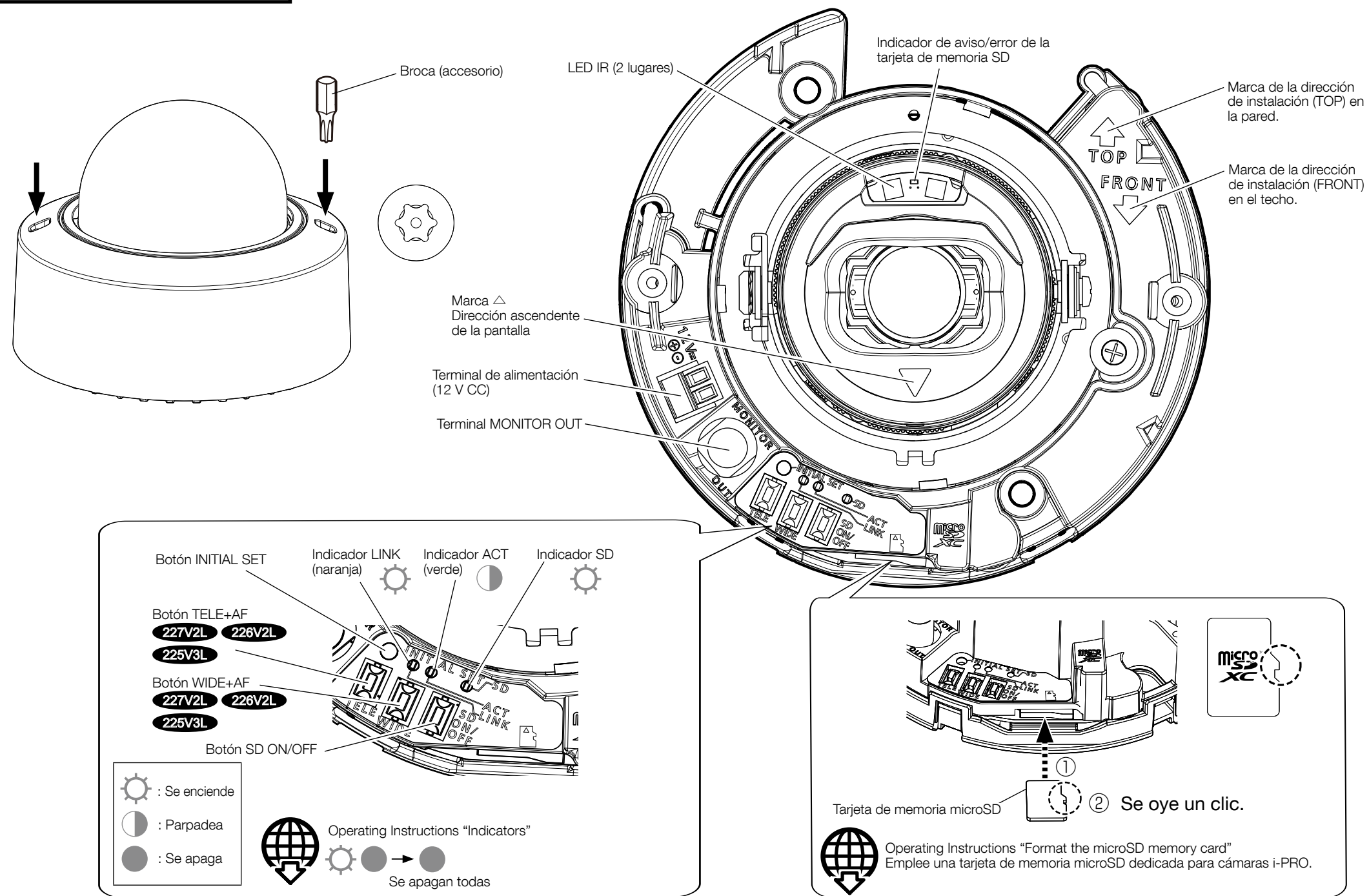



# Partes y funciones



# Paso 3

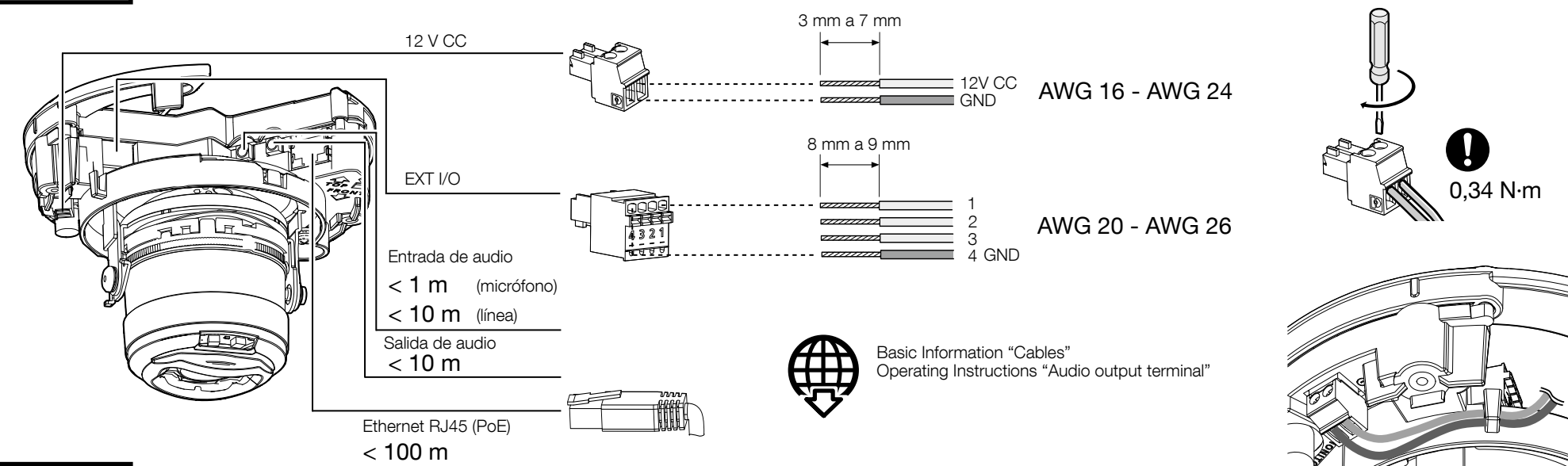

# Paso 4

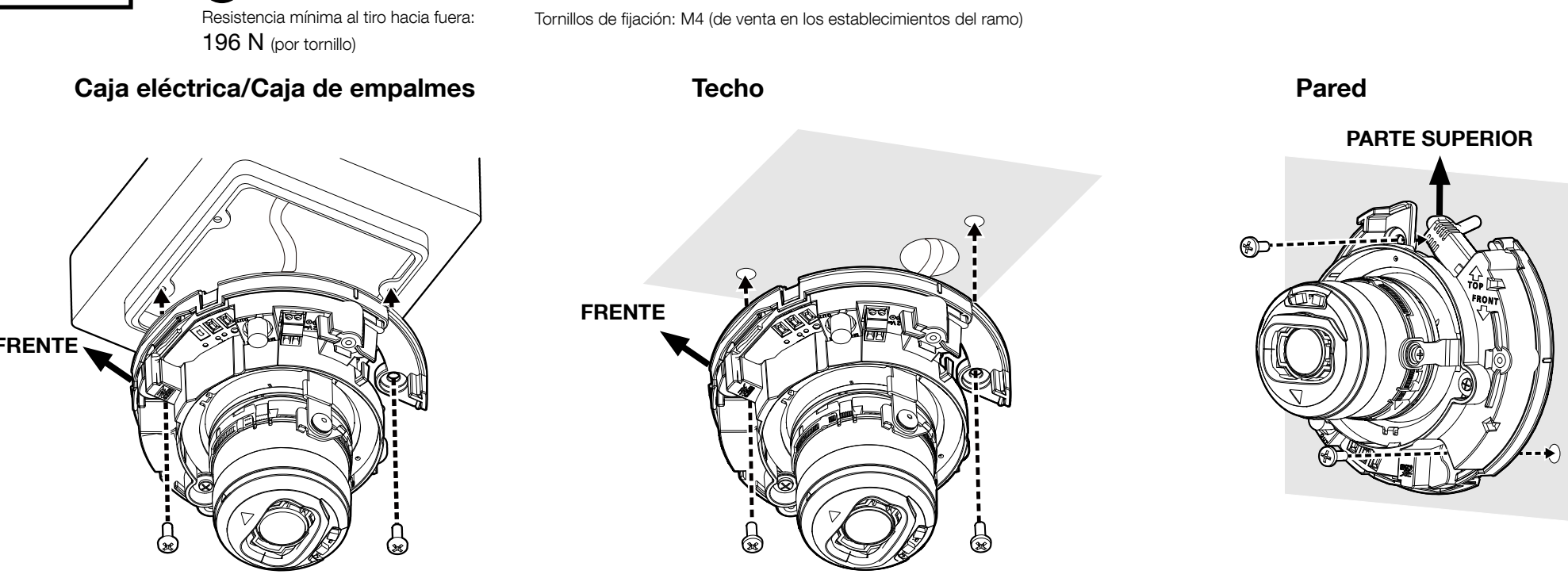

# Paso 1

## Preparativos

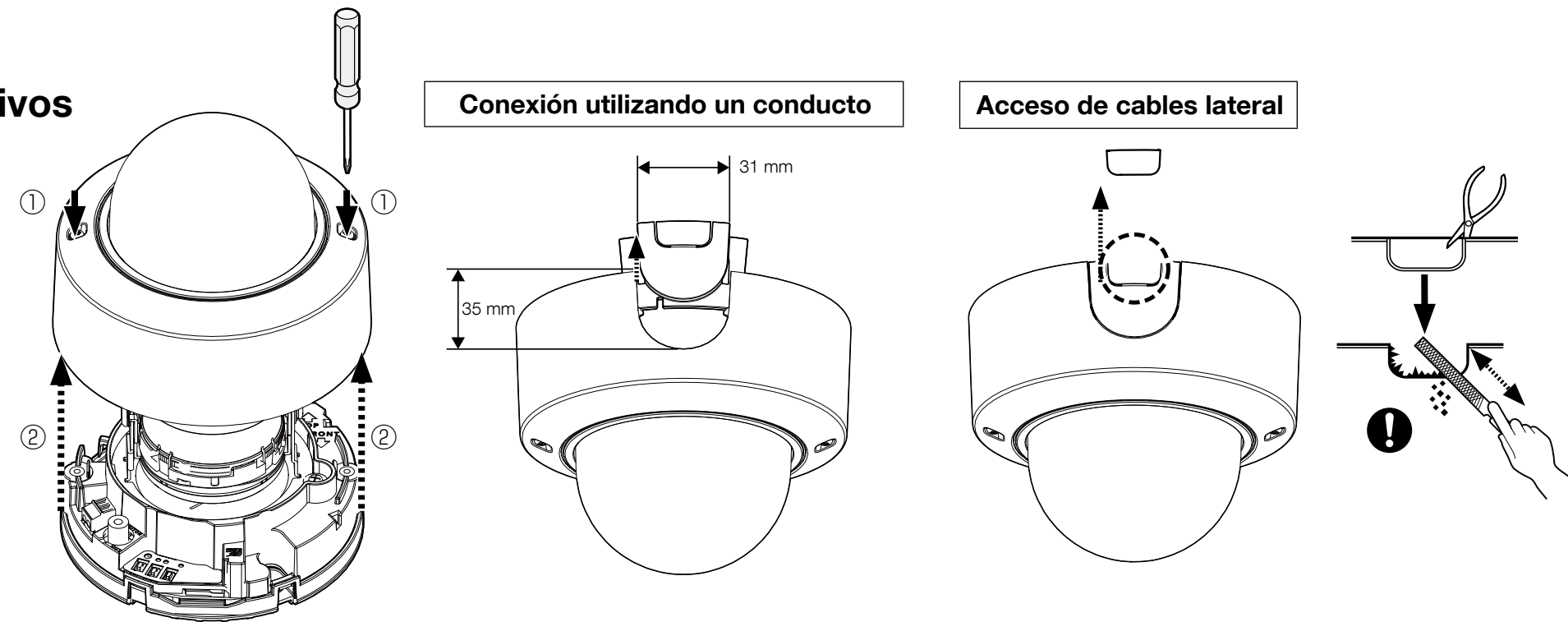

# Paso 2

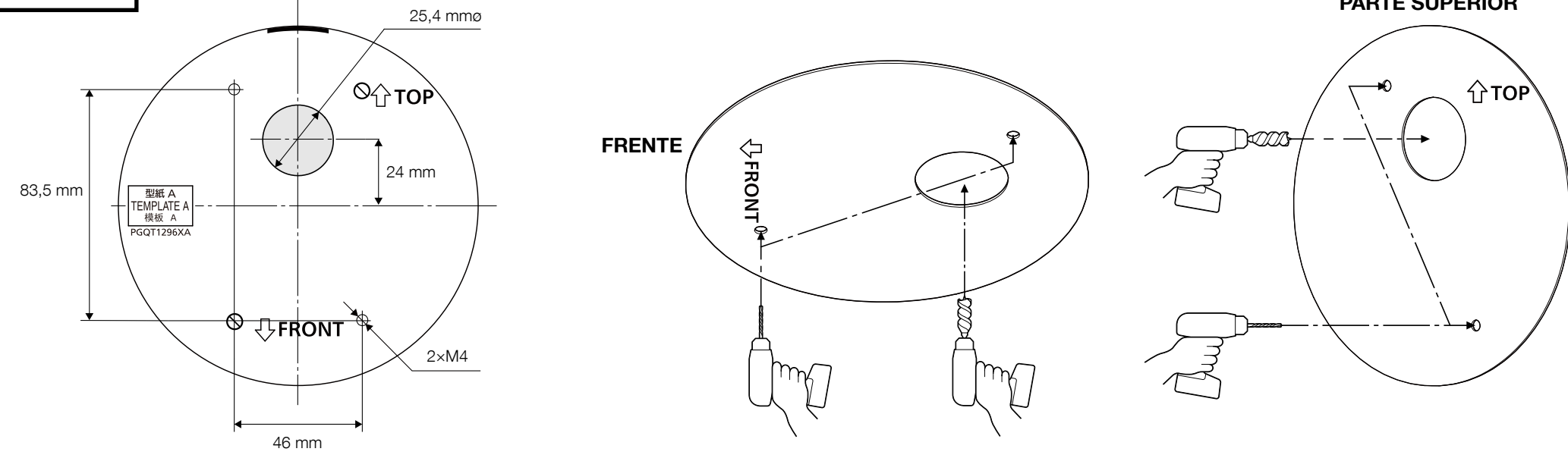

# Paso 5

→ Encendido (12 V CC/PoE)  
Si hay película protectora en el objetivo, retírela.

