

Manufactured for:

**i-PRO**



## INSTALLATION INSTRUCTIONS

Before attempting to connect or operate this product, please read instructions completely. Installation and Operation Instructions for the following model:

### **PWM25AW(AGS)**

**Wall mount Bracket**

Model Number and Description:

**PWM25AW** Wall Mount Bracket (White)

**PWM25AGS** Wall Mount Bracket (Silver)

#### **PWM25AW & PWM25AGS**



## IMPORTANT SAFEGUARDS

1. Read Instructions - All the safety and operating instructions should be read before the unit is operated.
2. Retain Instructions - The safety and operating instructions should be retained for future reference.
3. Heed Warnings - All warnings on the unit and in the operating instructions should be adhered to.
4. Follow Instructions - All operating and user instructions should be followed.
5. Electrical Connections - Only a qualified electrician should make electrical connections.
6. Attachments - Do not use attachments not recommended by the product manufacturer as they may cause hazards.
7. Cable Runs - All cable runs must be within permissible distance.
8. Mounting - This unit must be properly and securely mounted to a supporting structure capable of sustaining the weight of the unit.

Accordingly:

- The installation should be made by a qualified installer.
- The installation should be in compliance with local codes.
- Care should be exercised to select suitable hardware to install the unit, taking into account both the composition of the mounting surface and the weight of the unit.

Be sure to periodically examine the unit and the supporting structure to make sure that the integrity of the installation is intact. Failure to comply with the foregoing could result in the unit separating from the support structure and falling, with resultant damages or injury to anyone or anything struck by the falling unit.

## UNPACKING

Unpack carefully. Electronic components can be damaged if improperly handled or dropped. If an item appears to have been damaged in shipment, replace it properly in its carton and notify the shipper.

Be sure to save:



1. The shipping carton and packaging material. They are the safest material in which to make future shipments of the equipment.
2. These Installation and Operating Instructions.

## TECHNICAL SUPPORT

### FOR TECHNICAL SUPPORT

[i-pro.com/us/en/surveillance/support](http://i-pro.com/us/en/surveillance/support)  
1.800.513.5417  
M-F 7:00am – 7:00pm CST

## SAFETY PRECAUTIONS

|   |   |   |
|---|---|---|
|    | <b>CAUTION</b><br><b>RISK OF ELECTRICAL SHOCK</b><br><b>DO NOT OPEN</b> |  |
| <b>CAUTION: TO REDUCE THE RISK OF ELECTRIC SHOCK,</b><br><b>DO NOT REMOVE COVER (OR BACK).</b><br><b>NO USER SERVICEABLE PARTS INSIDE.</b><br><b>REFER SERVICING TO QUALIFIED SERVICE PERSONNEL</b> |   |   |



The lightning flash with an arrowhead symbol, within an equilateral triangle, is intended to alert the user to the presence of non-insulated "dangerous voltage" within the product's enclosure that may be of sufficient magnitude to constitute a risk of electric shock to persons.

Este símbolo se piensa para alertar al usuario a la presencia del "voltaje peligroso no-aislado" dentro del recinto de los productos que puede ser un riesgo del choque eléctrico.

Ce symbole est prévu pour alerter l'utilisateur à la présence "de la tension dangereuse" non-isolée dans la clôture de produits qui peut être un risque de choc électrique.

Dieses Symbol soll den Benutzer zum Vorhandensein der nicht-Isolier"Gefährdungsspannung" innerhalb der Produkteinschließung alarmieren, die eine Gefahr des elektrischen Schlages sein kann.

Este símbolo é pretendido alertar o usuário à presença "da tensão perigosa non-isolada" dentro do cerco dos produtos que pode ser um risco de choque elétrico

Questo simbolo è inteso per avvertire l'utente alla presenza "di tensione pericolosa" non-isolata all'interno della recinzione dei prodotti che può essere un rischio di scossa elettrica.



The exclamation point within an equilateral triangle is intended to alert the user to presence of important operating and maintenance (servicing) instructions in the literature accompanying the appliance.

Este símbolo del punto del exclamation se piensa para alertar al usuario a la presencia de instrucciones importantes en la literatura que acompaña la aplicación.

Ce symbole de point d'exclamation est prévu pour alerter l'utilisateur à la présence des instructions importantes dans la littérature accompagnant l'appareil.

Dieses Ausruf Punktsymbol soll den Benutzer zum Vorhandensein der wichtigen Anweisungen in der Literatur alarmieren, die das Gerät begleitet

Este símbolo do ponto do exclamation é pretendido alertar o usuário à presença de instruções importantes na literatura que acompanha o dispositivo.

Questo simbolo del punto del exclamation è inteso per avvertire l'utente alla presenza delle istruzioni importanti nella letteratura che accompagna l'apparecchio.

1

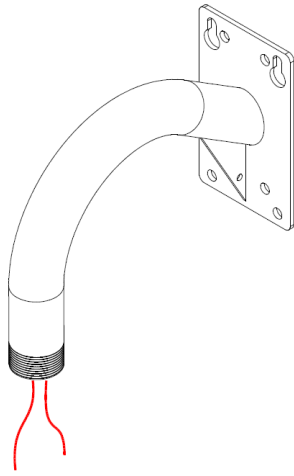

Securely mount bracket to wall using appropriate fasteners. Pull wiring through bracket.

2

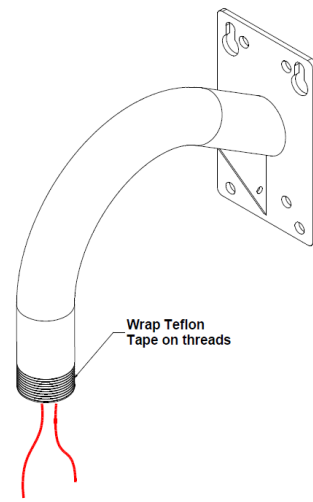

Wrap Teflon tape around the pipe threads to ensure a tight seal.

# Dimensions

