

Installation Procedure

Parts and functions

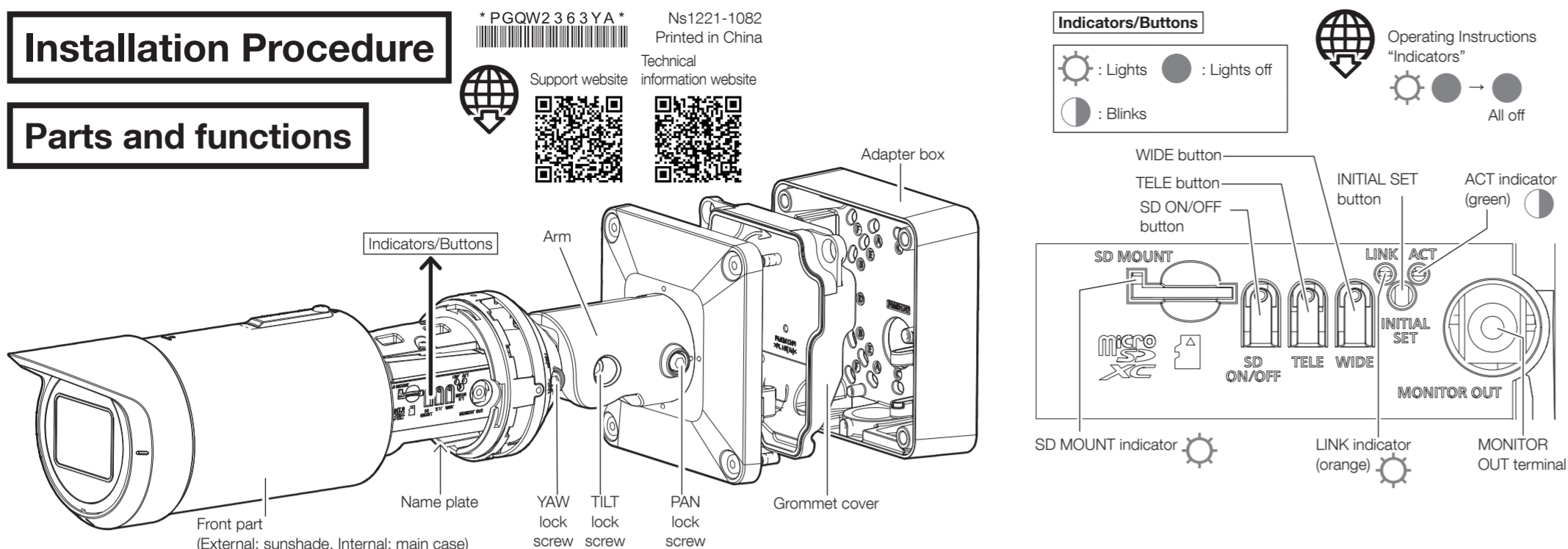

Installation method

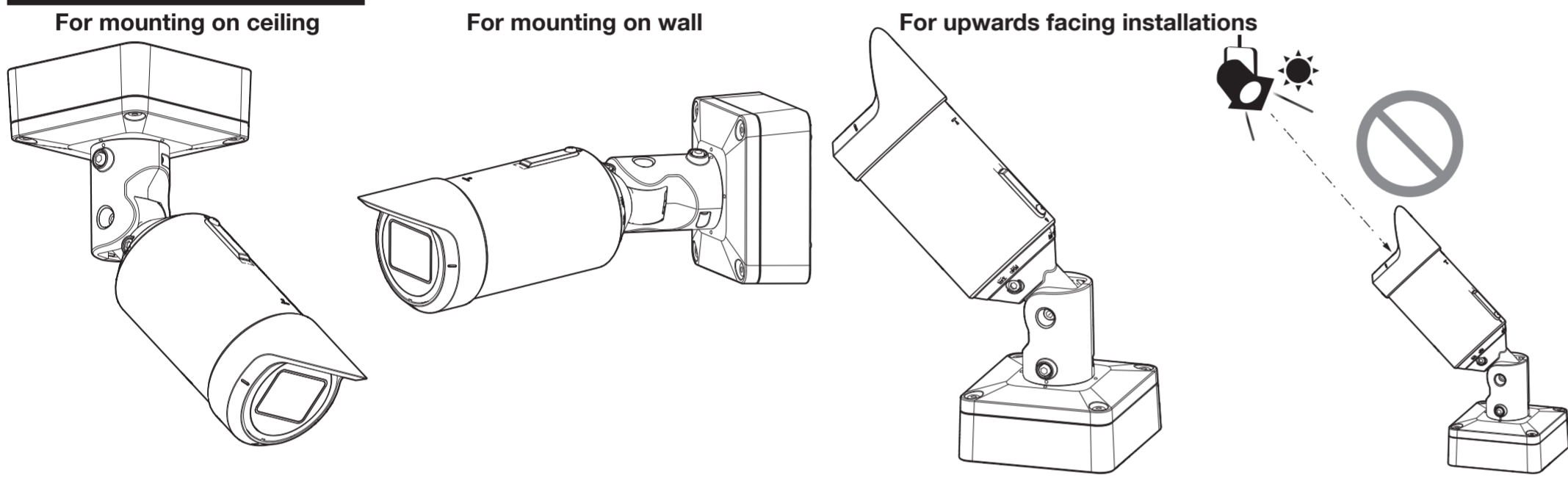

Step1 Preparations

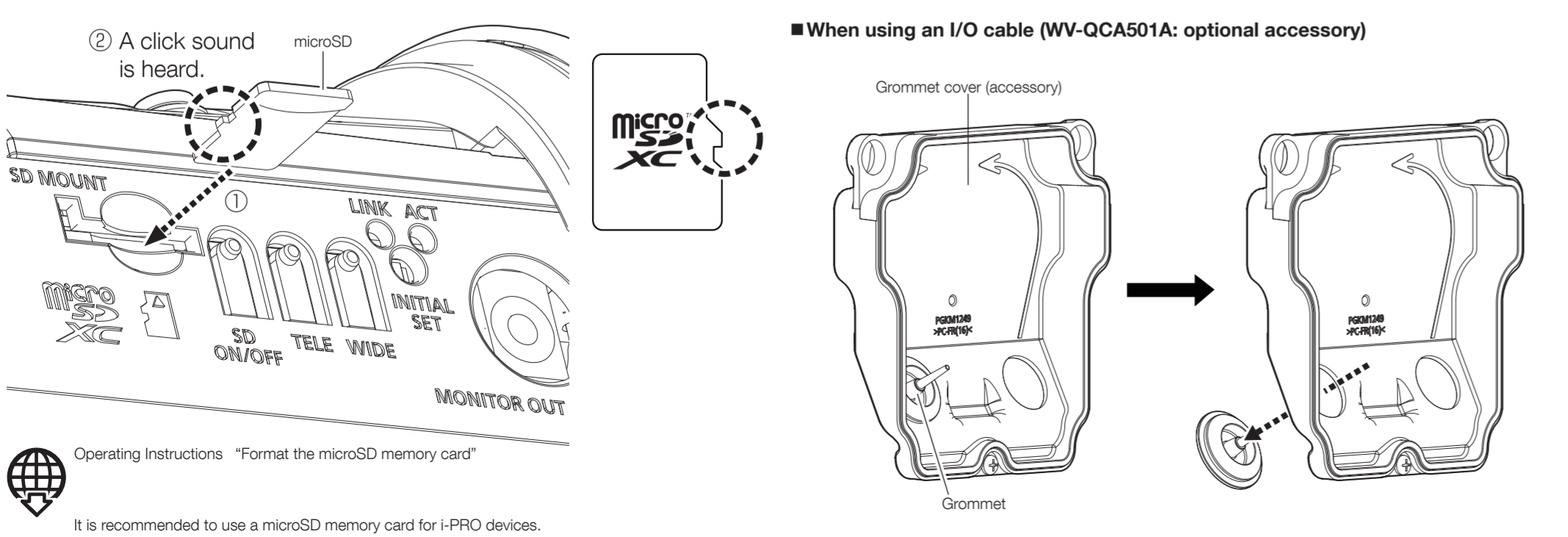
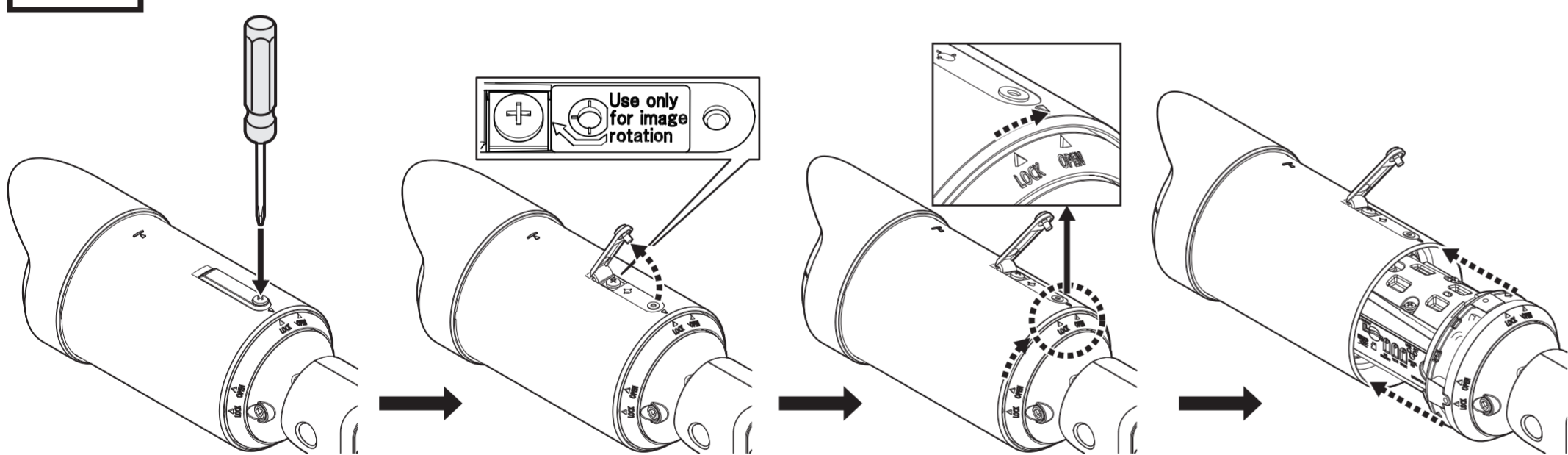

Step2

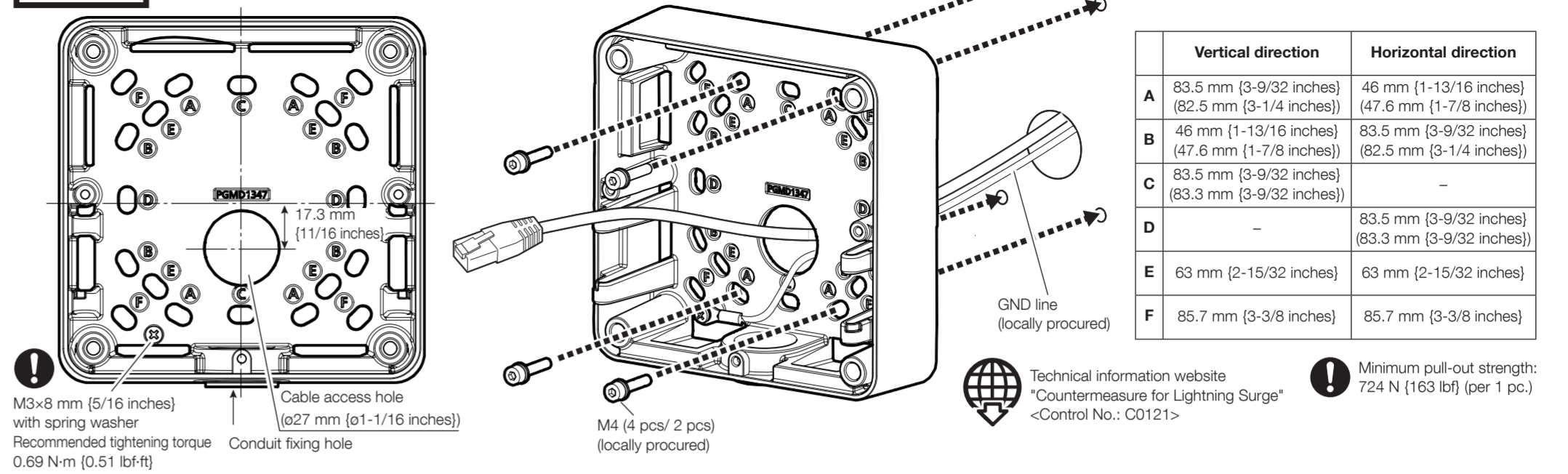

Step3

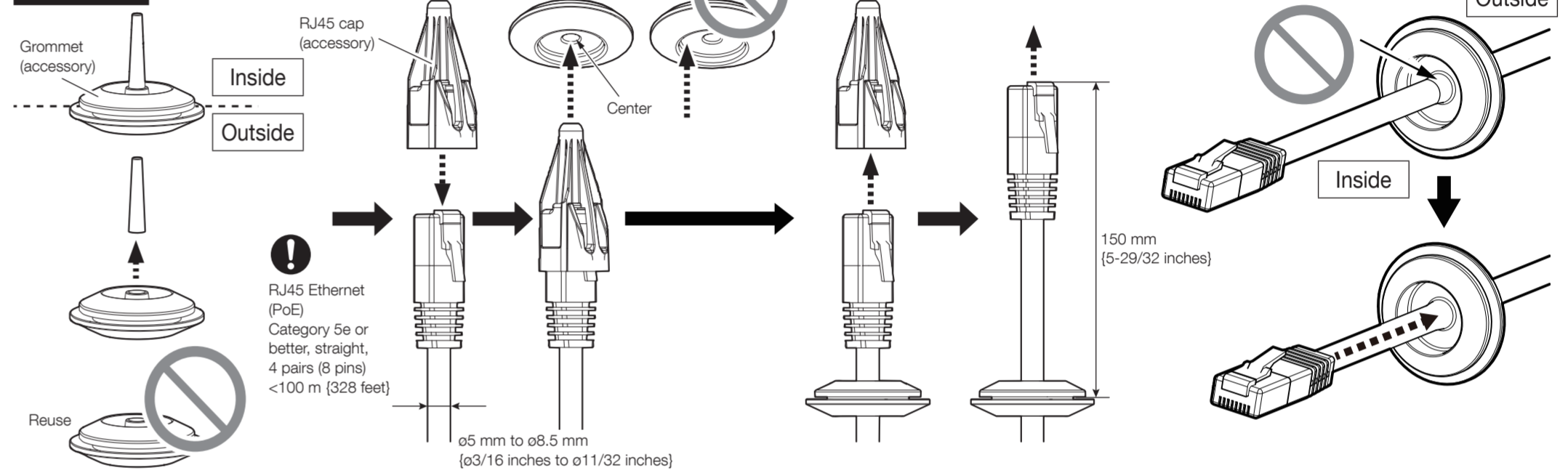

When using an I/O cable (WV-QCA501A: optional accessory)

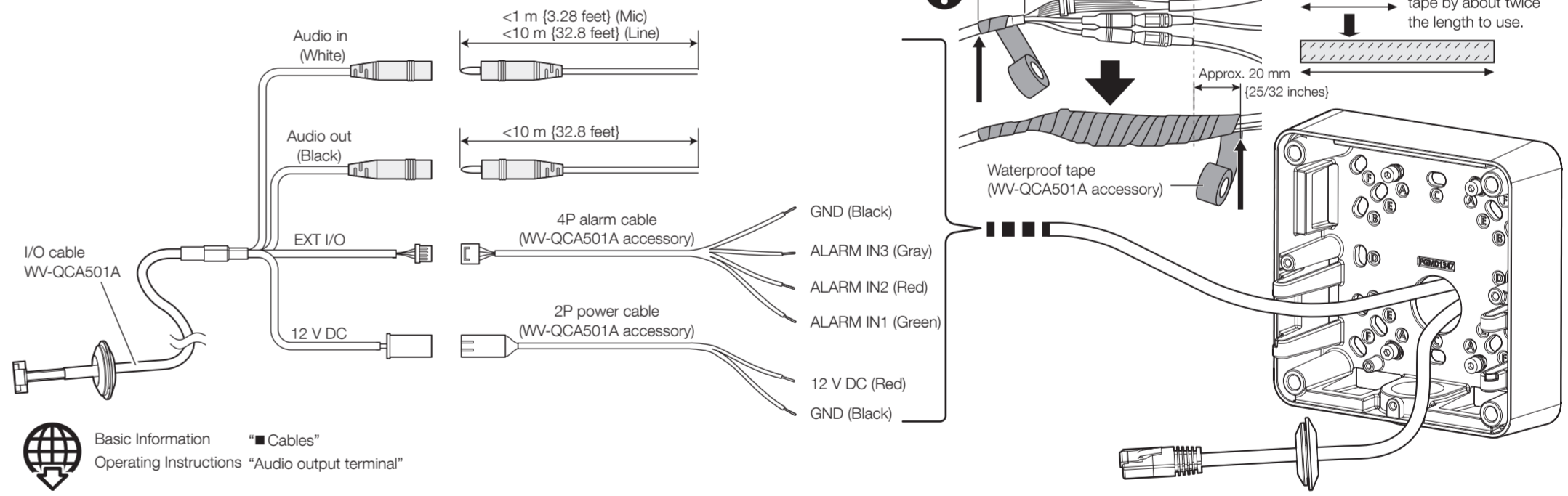

Step4-1

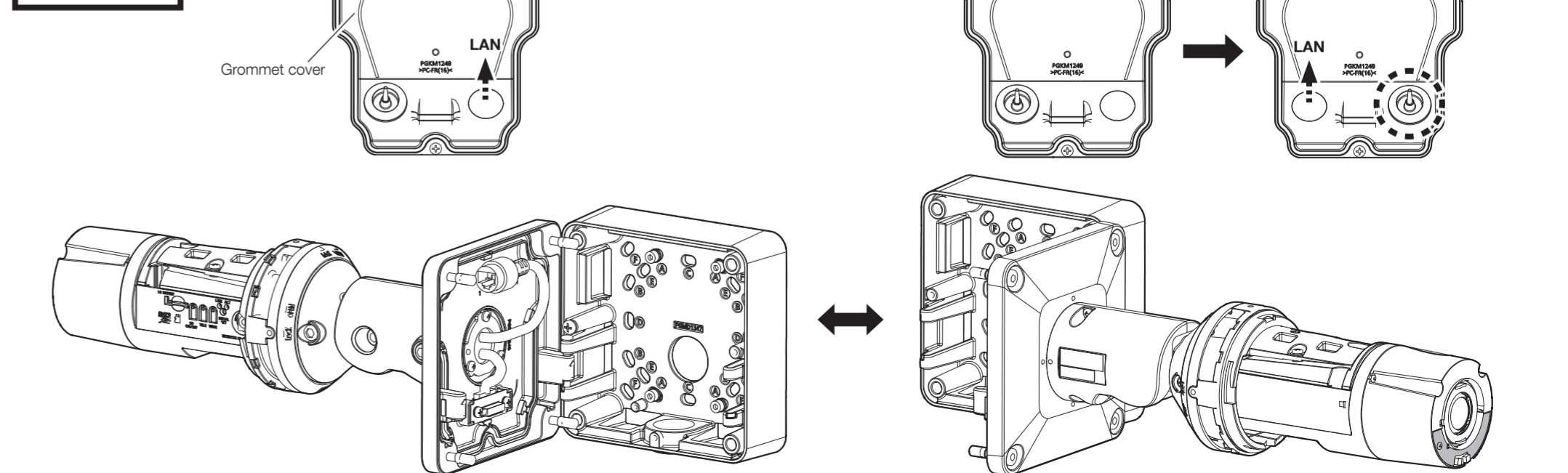

Step4-2

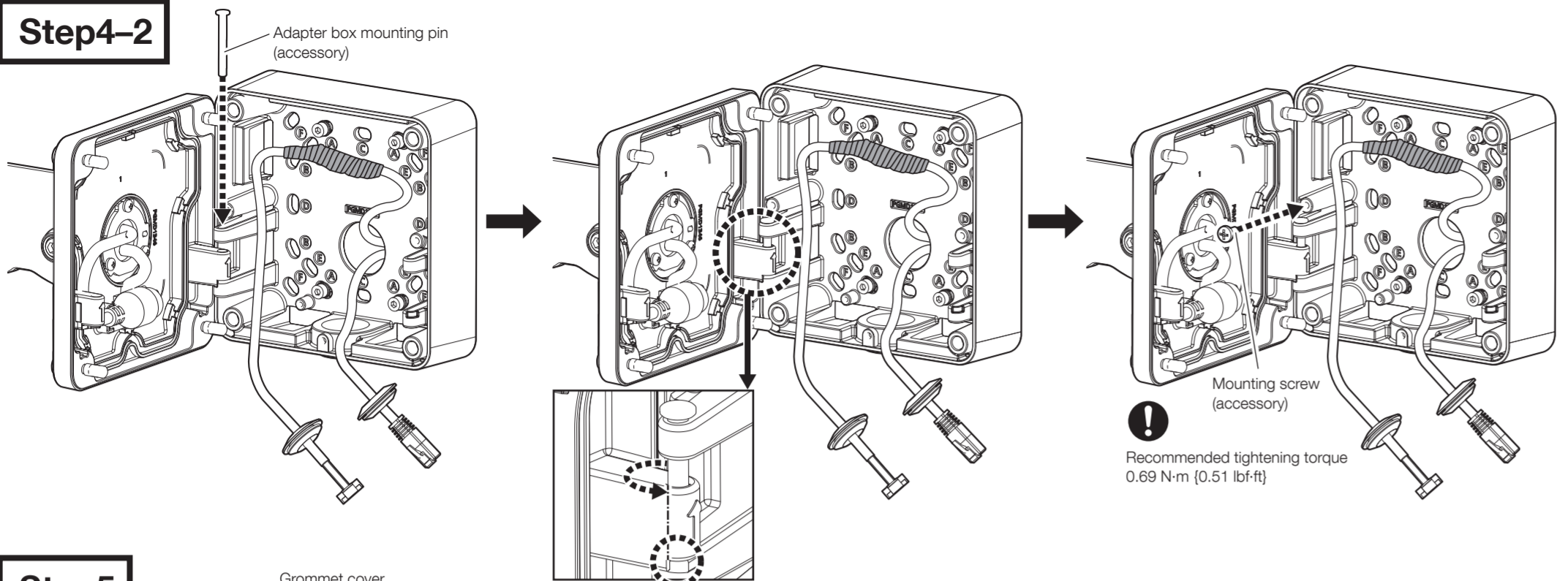

Step5

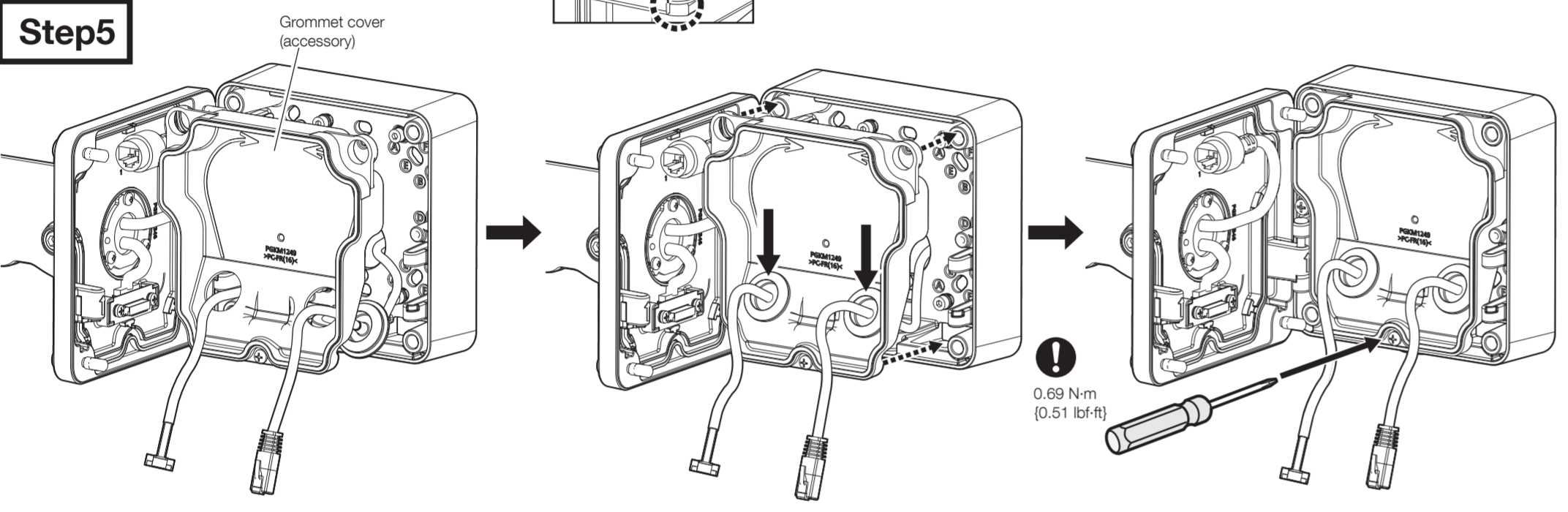

Step6

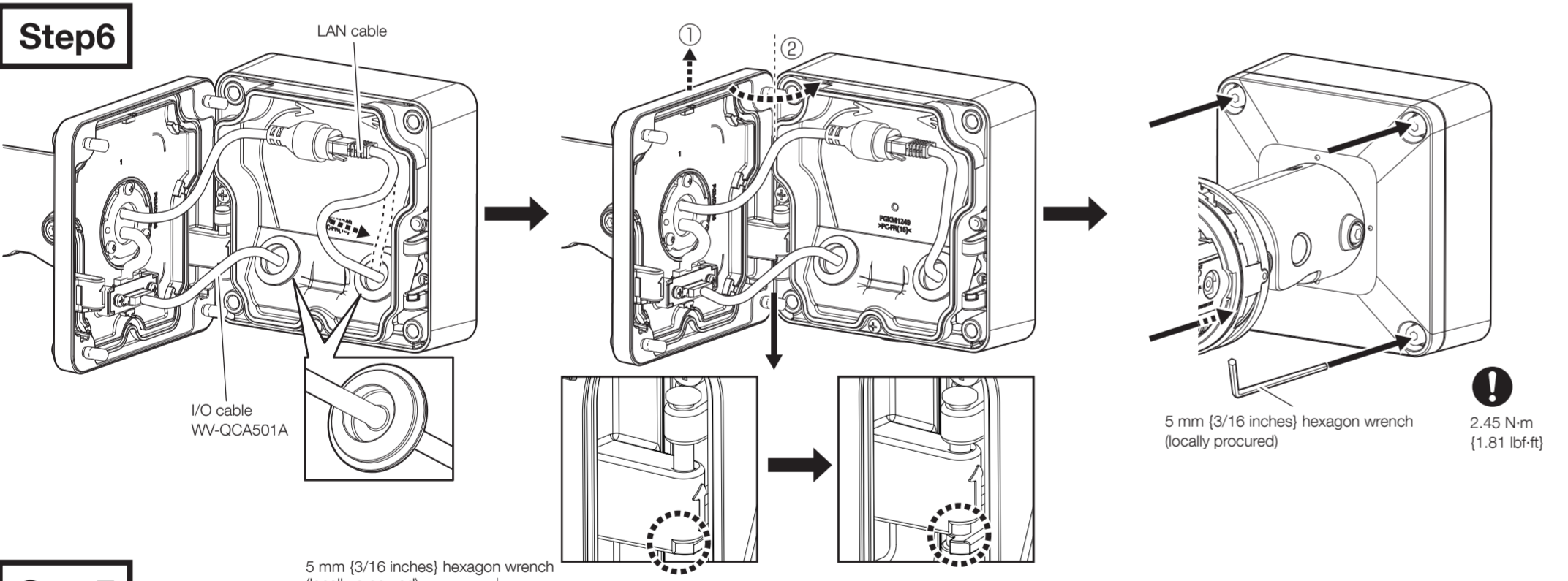

Step7

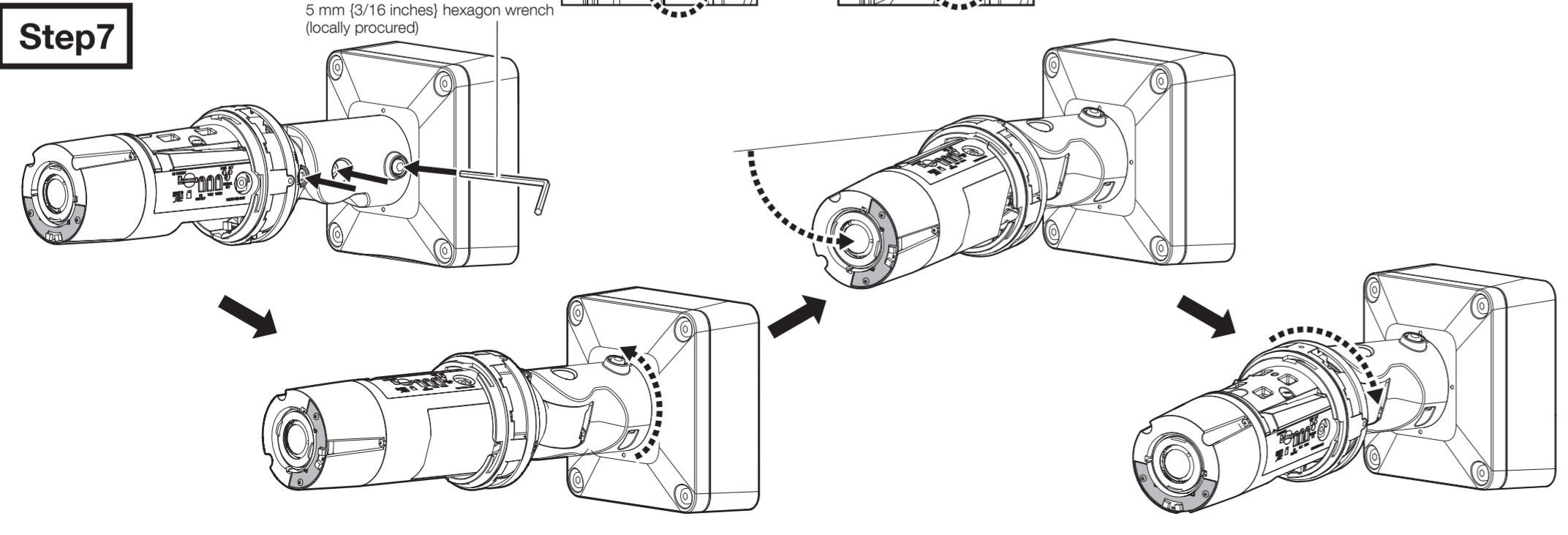

Step8

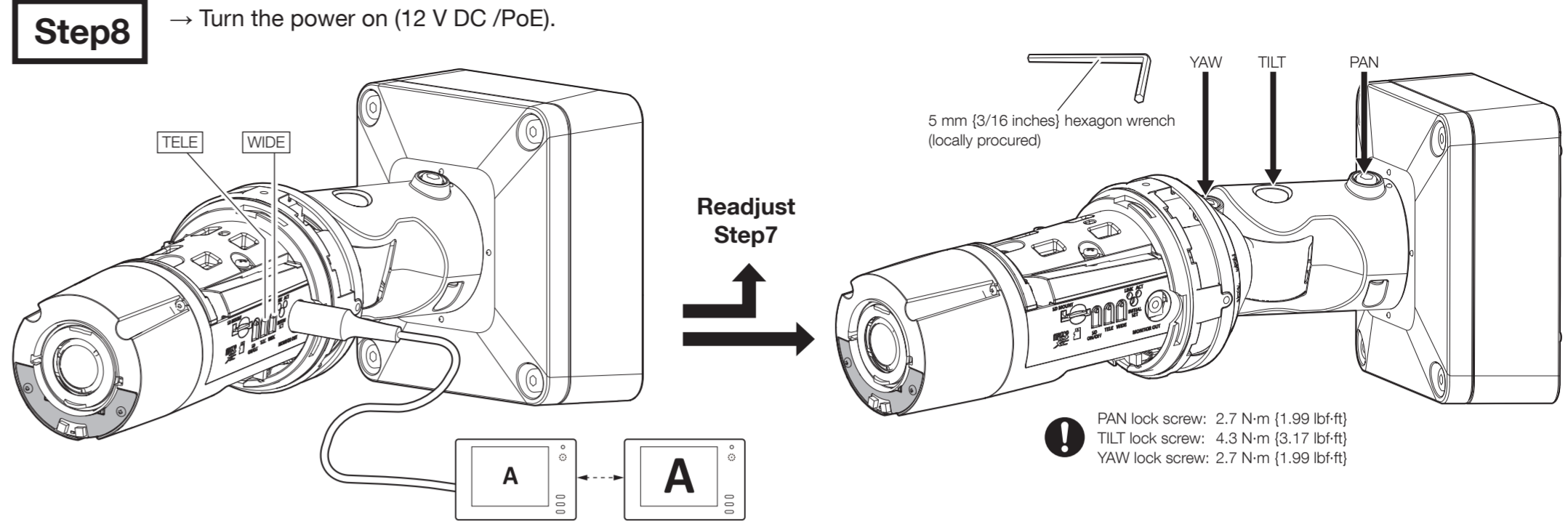

Step9

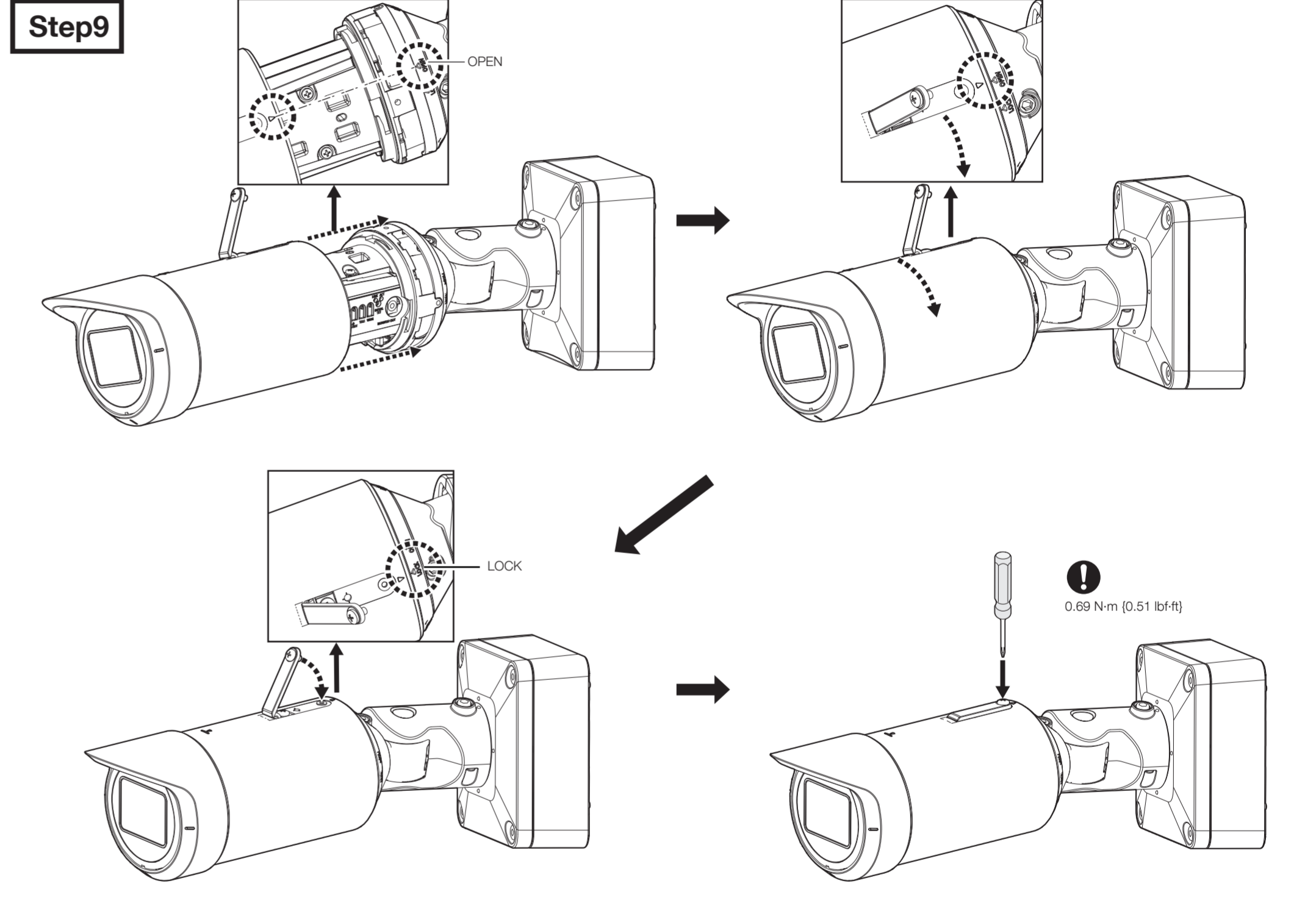

Step10

