

Partes y funciones

■ A continuación se indican las descripciones al usar el modelo S2136L

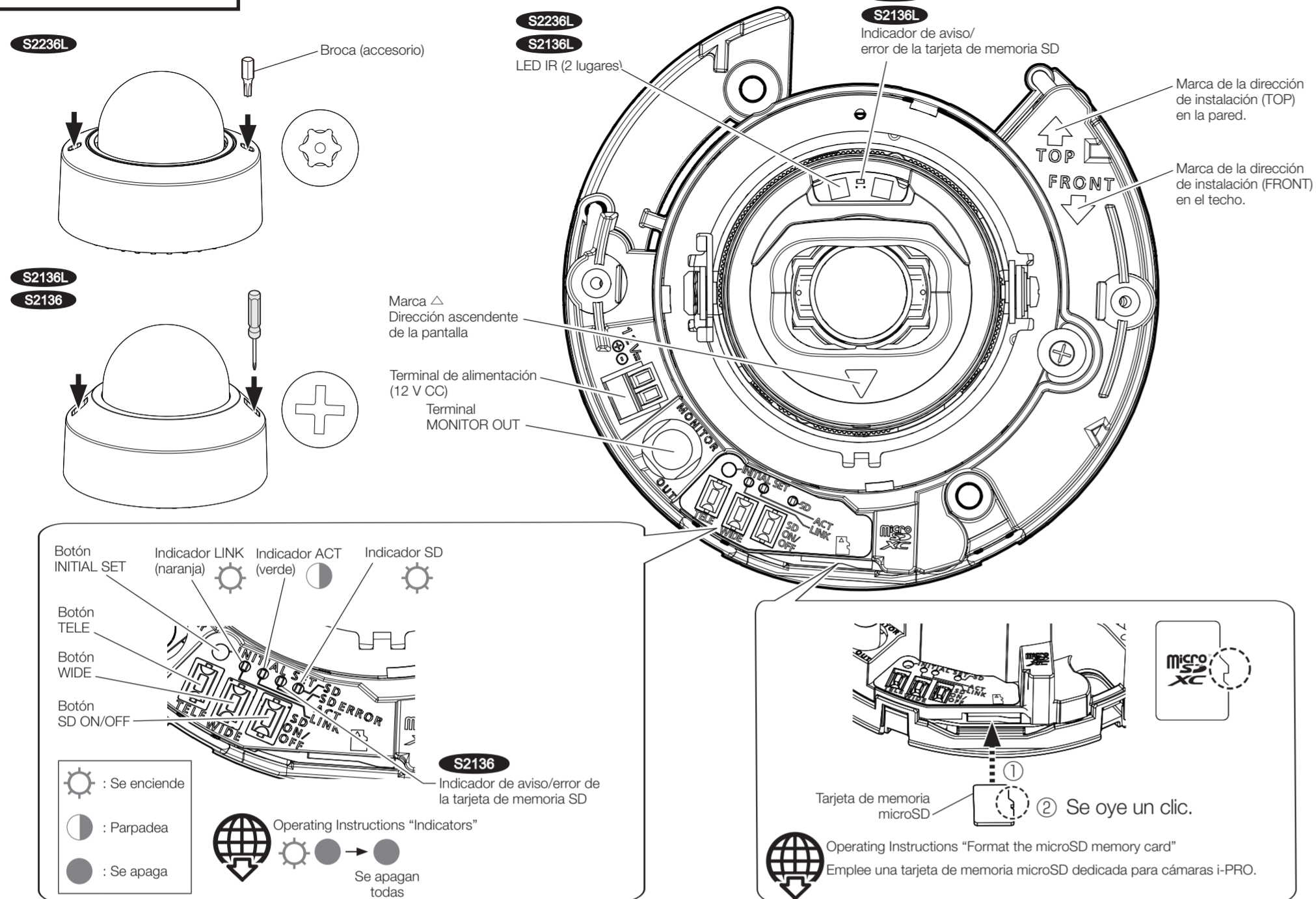

Paso 3

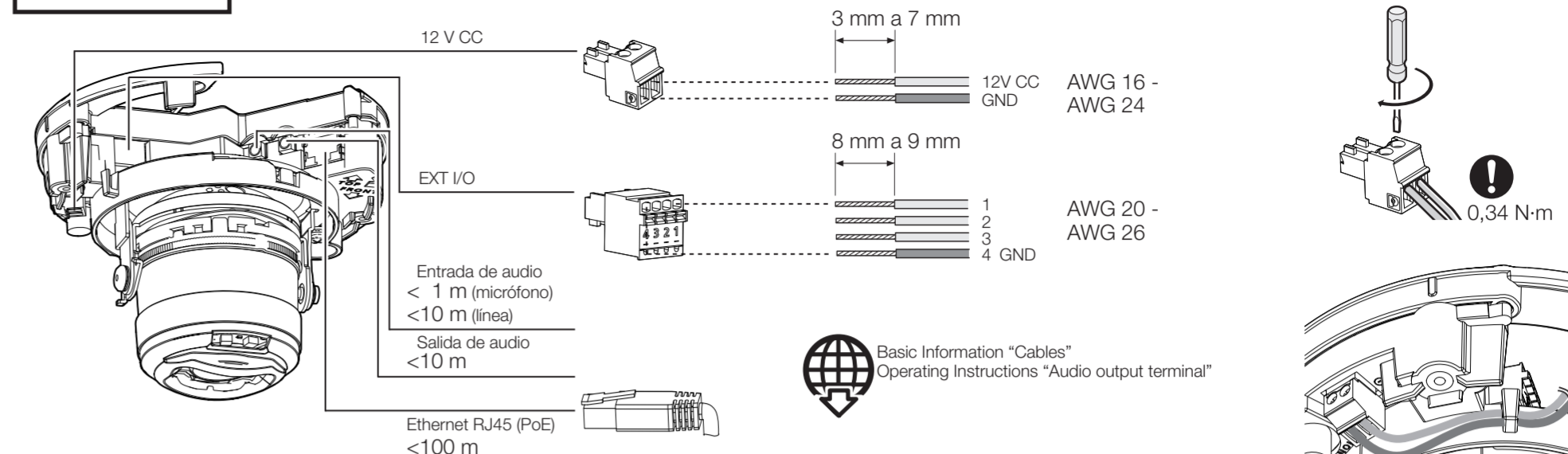

Paso 4

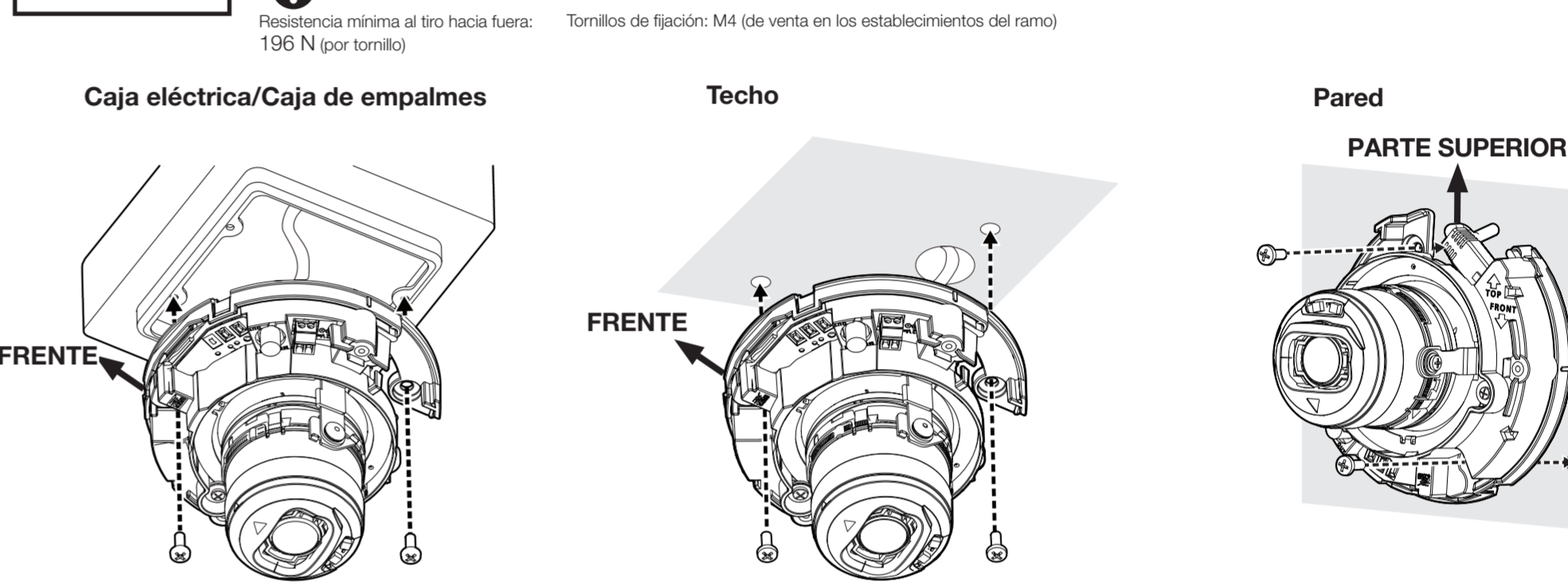

Paso 1

Preparativos

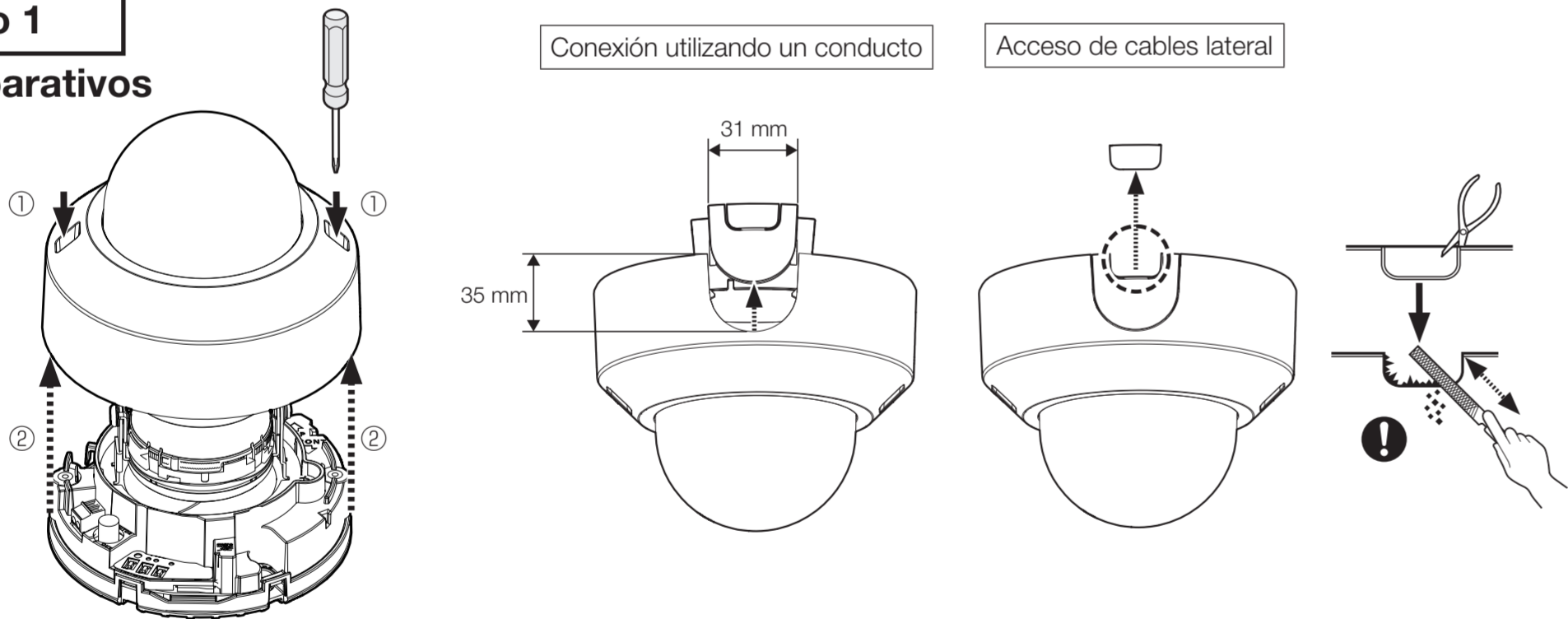

Paso 2

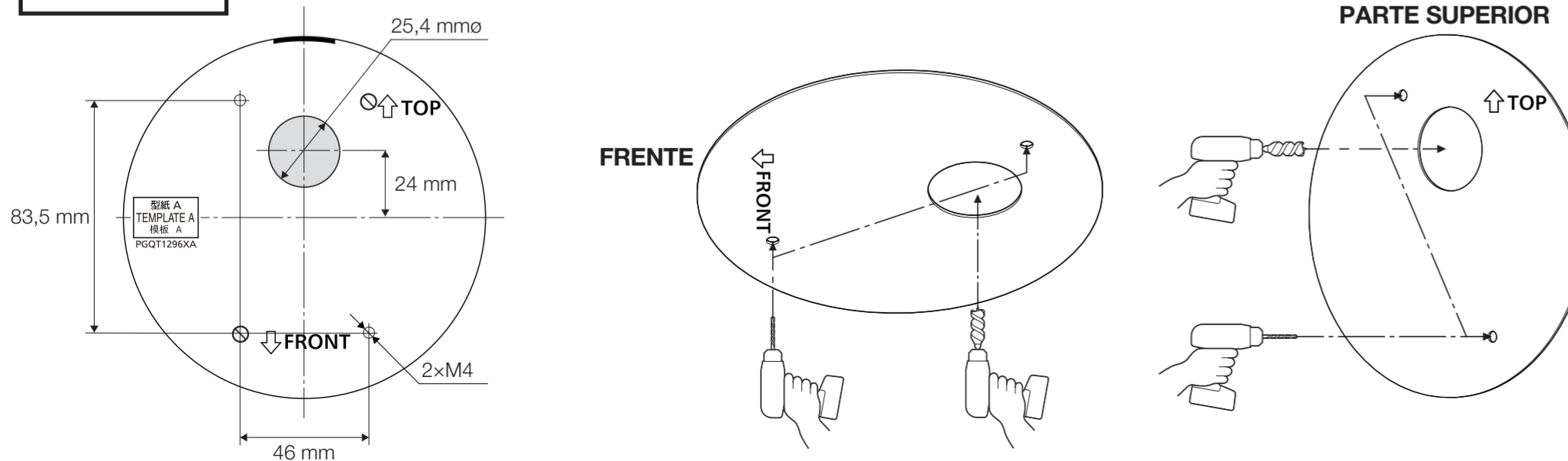

Paso 5

→ Encendido (12 V CC/PoE)
Si hay película protectora en el objetivo, retírela.

